



Building Guide

Colorado Chapter of the International Code Council

Single Family Residential Uncovered Decks and Porches

How to Use this Guide

Provide two sets of plans and complete the following:

1. **Complete this Building Guide** by filling in the blanks on page two, and indicating which construction details will be used.
2. **Provide 2 Plot Plans (site plan)** showing dimensions of your project or addition and its relationship to existing buildings or structures on the property and the distance to existing property lines drawn to scale.
3. **Fill out a building permit application.**

The majority of permit applications are processed with little delay. The submitted documents will help determine if the project is in compliance with building safety codes, zoning ordinances and other applicable laws.

The Colorado Chapter of the International Code Council is a professional organization seeking to promote the public health, safety and welfare to building construction. We appreciate your feedback and suggestions. To obtain a master copy of this building guide, please write to the Colorado Chapter of the International Code Council, PO Box 961, Arvada, CO 80001
<http://www.coloradochaptericc.org>

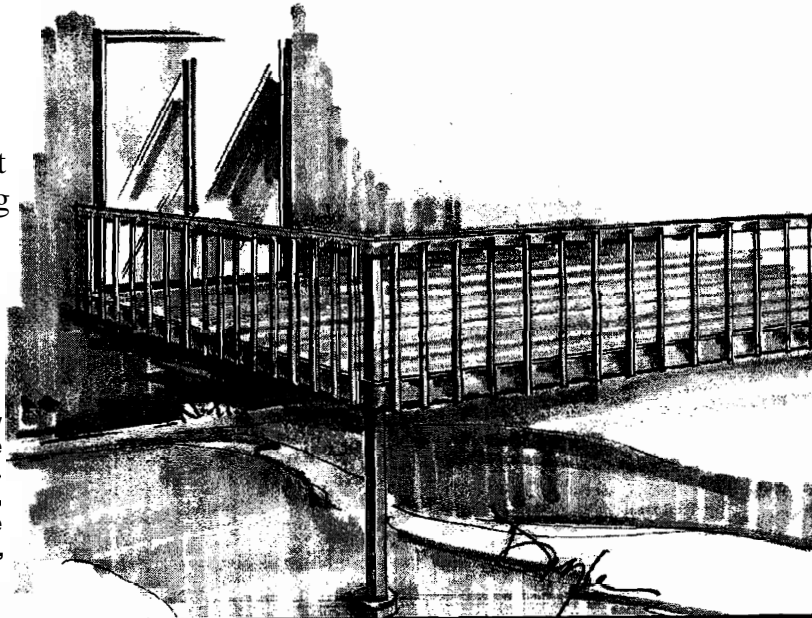

This handout was developed by the Colorado Chapter of the International Code Council as a basic plan submittal under the 2006 International Residential Code. It is not intended to cover all circumstances. Check with your Department of Building Safety for additional requirements.

Greeley
Colorado
GREECE FROM THE CR. OF A D.

City of Greeley
 Building Inspection Division
 1100 10th Street, Suite 114
 Greeley, CO 80631

Single Family Residential Uncovered Decks and Porches

Directions

1. Fill in the blanks on pages 2 and 3 with dimensions and materials which will be used to build the structure. Please print legibly.
2. Indicate in the check box which detail from page 3 will be used.

Address: _____

Size and Amount of Lags

 (example: Two 3/8"x 4 1/2" lags @ 16" O.C.)

Type of decking _____ x _____
 (example: 1 x 4 or 2 x 6 - Trex)

Deck Section

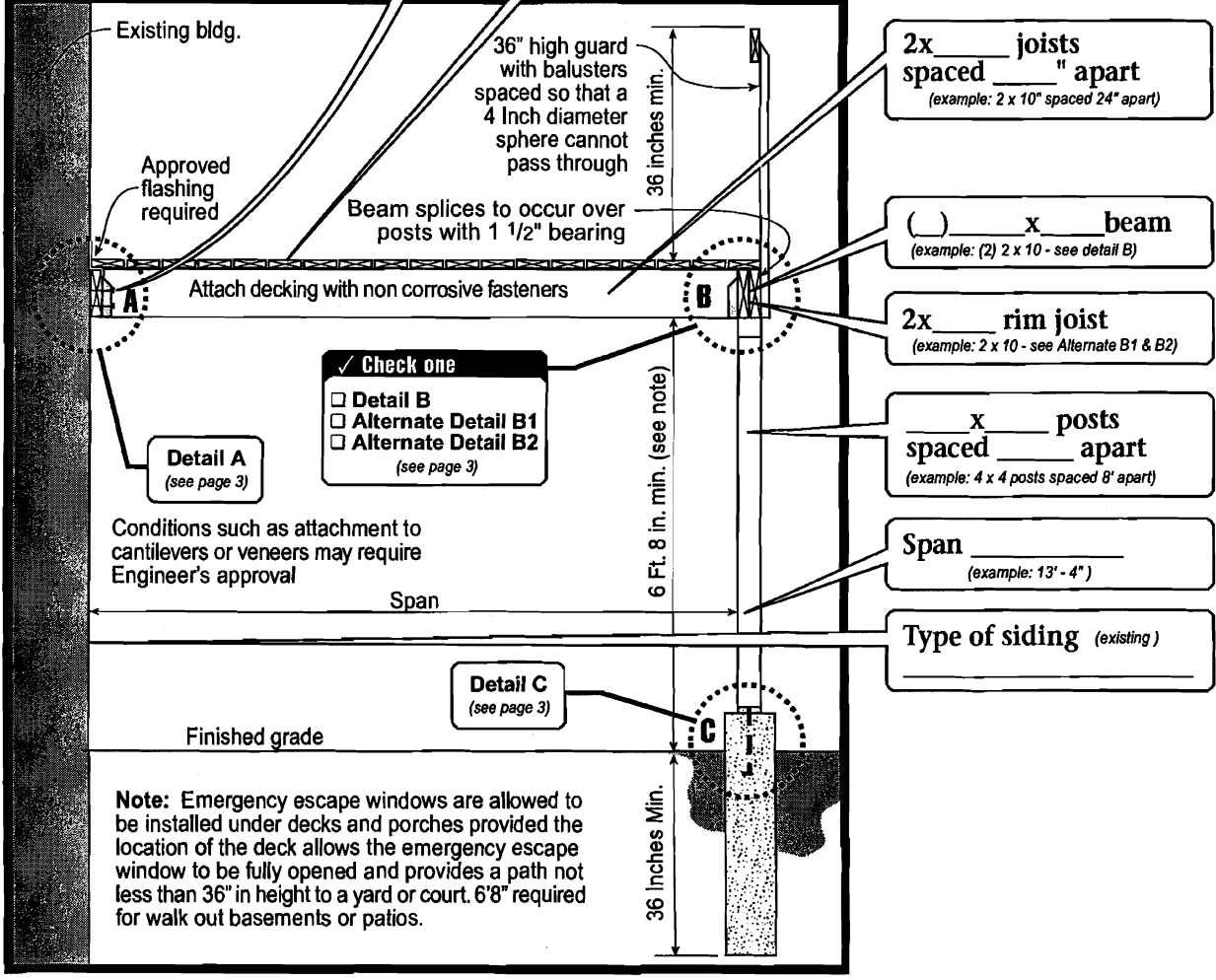

Note: A plot plan (plan view) showing the dimensions of your project or additions and its relationships to existing buildings or structures on the property must be included. In addition to project dimensions, your plot plan must also show other details such as post locations and spacing, joist and beam spans, and any other pertinent information not shown on the section drawing.

This handout was developed by the Colorado Chapter of the International Code Council as a basic plan submittal under the 2006 International Residential Code. It is not intended to cover all circumstances. Check with your Department of Building Safely for additional requirements.



City of Greeley
 Building Inspection Division
 1100 10th Street, Suite 114
 Greeley, CO 80631

Single Family Residential Uncovered Decks and Porches

Detail A

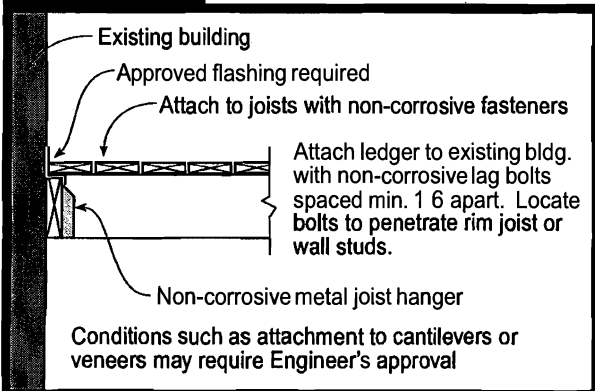

Detail B

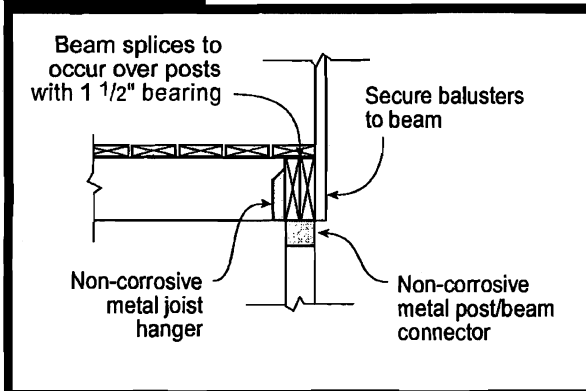

Alternate Detail B1

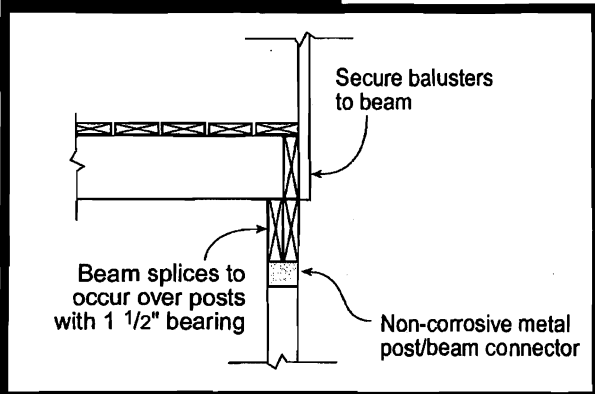

Alternate Detail B2

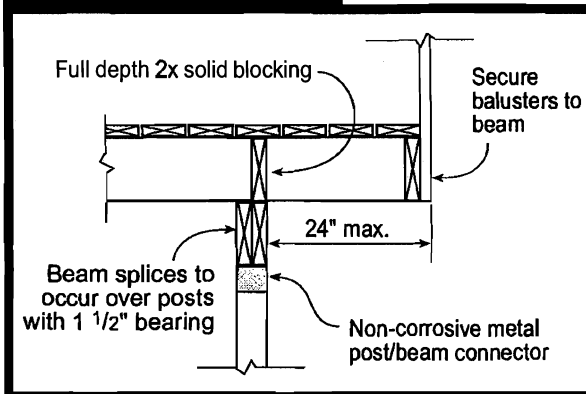

Detail C

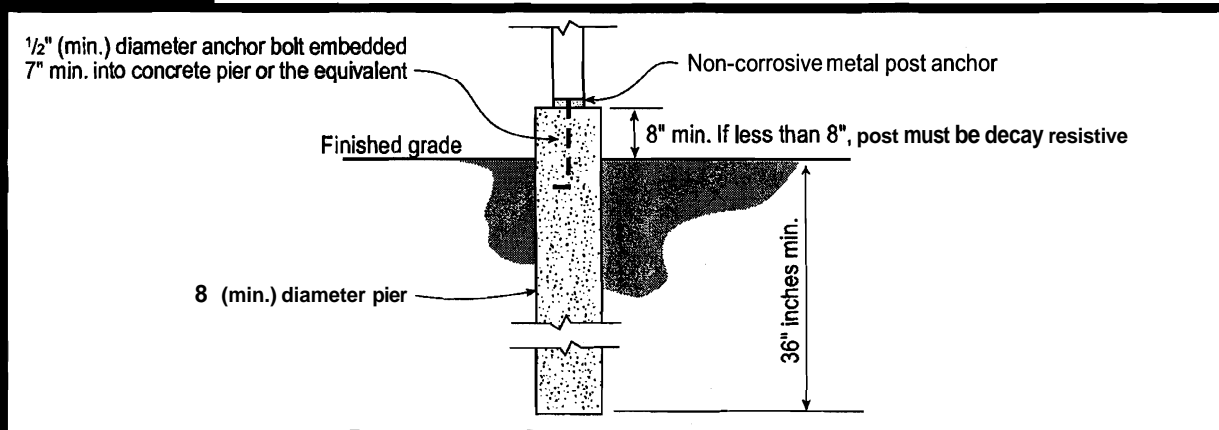

This handout was developed by the Colorado Chapter of the International Code Council as a basic plan submittal under the 2006 International Residential Code. It is not intended to cover all circumstances. Check with your Department of Building Safety for additional requirements.



City of Greeley
 Building Inspection Division
 1100 10th Street, Suite 114
 Greeley, CO 80631

Single Family Residential Uncovered Decks and Porches

Stair & Handrail Specifications

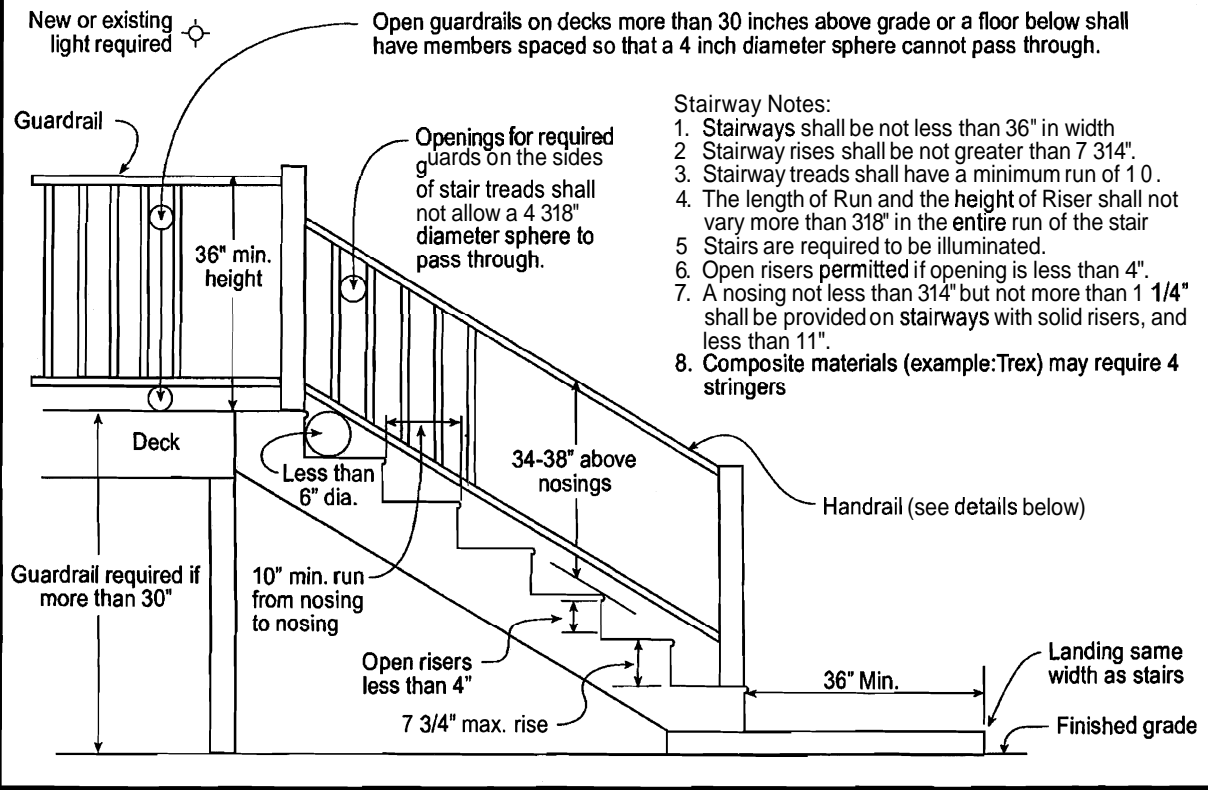

- Stairway Notes:**
1. Stairways shall be not less than 36" in width
 2. Stairway rises shall be not greater than 7 3/4"
 3. Stairway treads shall have a minimum run of 10.
 4. The length of Run and the height of Riser shall not vary more than 3/8" in the entire run of the stair
 5. Stairs are required to be illuminated.
 6. Open risers permitted if opening is less than 4".
 7. A nosing not less than 1/4" but not more than 1 1/4" shall be provided on stairways with solid risers, and less than 11".
 8. Composite materials (example:Trex) may require 4 stringers

Handrail Notes:

1. Handrails shall be continuous on at least one side of stairs with 4 or more risers
2. Top of the handrails shall be placed not less than 34 inches nor more than 38 inches above stair nosings.
3. The handgrip portion of handrails shall be not less than 1-1 1/4 inches nor more than 2 1/4 inches in cross section for non circular handrails
4. Handrails shall be placed not less than 1-1 1/2 inches from any wall or other surface
5. Handrails to be returned to wall, post or safety terminal(per 311.5.6.2 IRC)

Acceptable Handrail Details

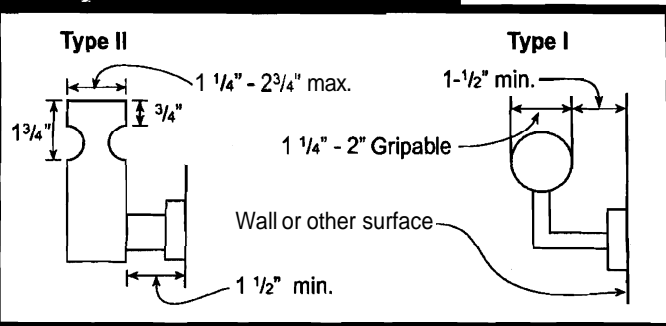

Unacceptable Handrails

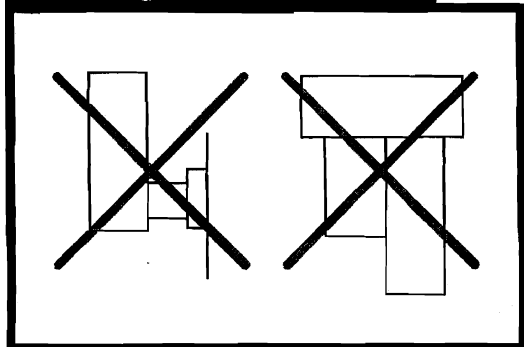

This handout was developed by the Colorado Chapter of the International Code Council as a basic plan submittal under the 2006 International Residential Code. It is not intended to cover all circumstances. Check with your Department of Building Safety for additional requirements.



City of Greeley
 Building Inspection Division
 1100 10th Street, Suite 114
 Greeley, CO 80631



Additions

Owner _____

Address _____ Telephone _____

Zoning of Property _____

Prior to application to the Building Inspection Division for a building permit for An addition, please provide the following information to the Planning Division, For review and approval: (Property owner must sign and initial)

1. Site plan, drawn to scale, which shows:
 - A. Location of the proposed addition relative to property lines.
 - B. Footprint of the principal building, including the garage.
 - C. Lot coverage, percent of building coverage, percent of landscaping coverage, percent of area covered in a hard surface.
 (See sample site plan on the back of this sheet.)

2. Building elevations, drawn to scale, which shows:
 - A. The existing structure.
 - B. All sides of the addition.
 - C. Proposed exterior materials and colors.

3. For additions, indicate your intent to comply with the following by placing your initials on the line provided:
 - ___ A. The proposed addition will have a point of attachment constituting a minimum of 20% of the circumference of the exterior walls of the addition.
 - ___ B. The maximum height of the addition shall be limited to 150% of the average height of the existing principal structures on the block face.
 - ___ C. The maximum length and width of an addition shall be limited to 150% of the average length and width of perimeter walls of the existing principal structures on the block face.
 - ___ D. The addition will be constructed of similar materials and in a similar design as the principal structure.

4. For patio covers, carports, decks, **and/or** porches, indicate your intent to comply with the following by placing your initials on the line provided:
 - ___ A. Porches and patios attached to the principal building, whether or not covered by roofs, may extend to within 10' of the front property line, provided that such remain at least 65% open and unobstructed on three sides.
 - ___ B. Patio covers, carports, decks, **and/or** porches may extend into the rear setback to within 5', provided that such shall remain at least 65% open and unobstructed on three sides.
 - ___ C. Uncovered porches and patios shall be permitted within required interior side yard setbacks.

This is to certify that I/we have read and understand the conditions of the Greeley Development Code concerning additions I/we agree to abide by the conditions stated herein.

Date _____

Property Owner's Signature

Reviewed for Zoning Compliance by _____

Date _____

(See reverse side for any additional comments)

Comments: _____

EXAMPLE

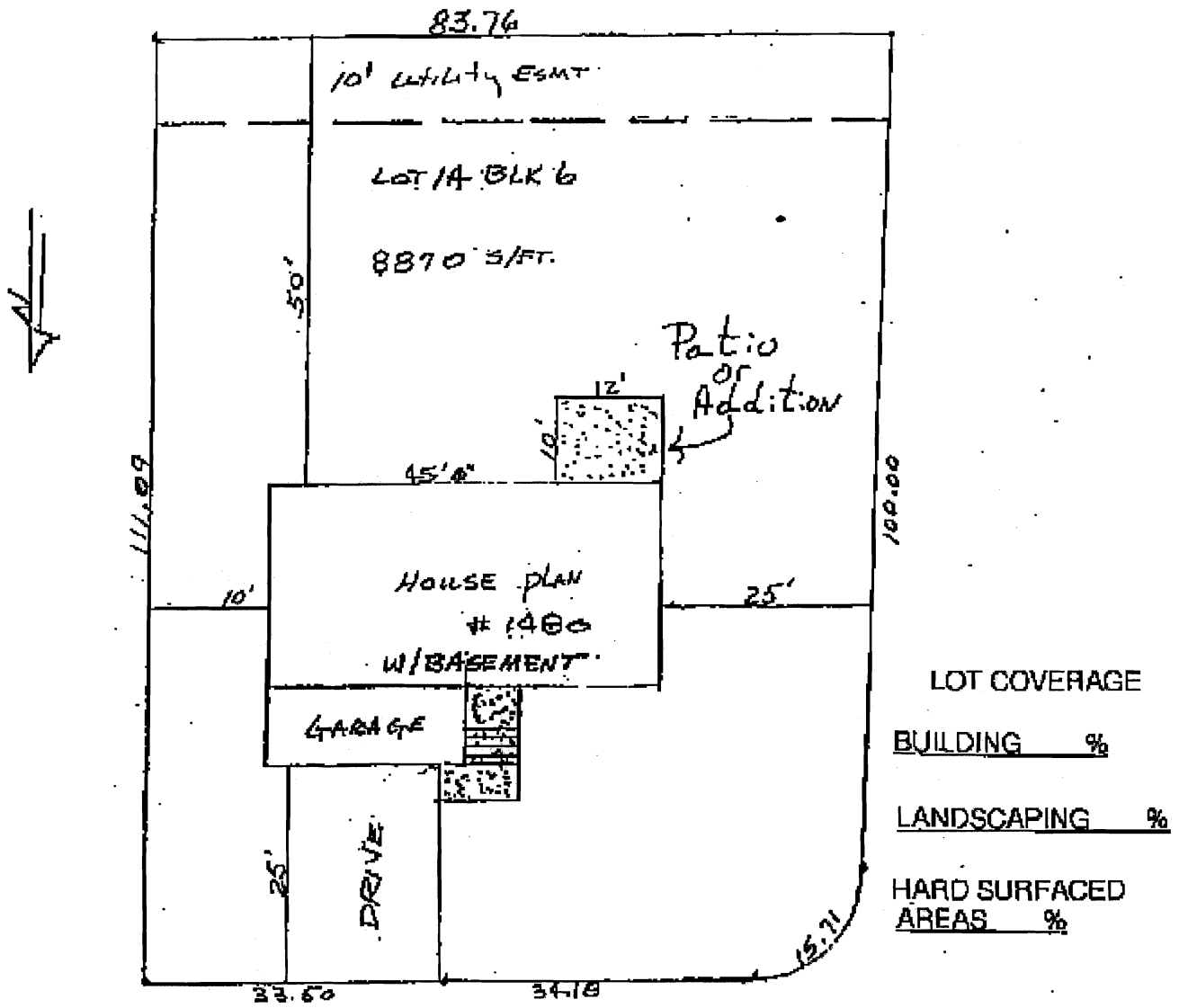

Scale 1" = 20'

SITE PLAN