



Building Guide

Colorado Chapter of the International Code Council

Single Family Residential One Story Detached Garage

How to Use this Guide

Provide two sets of plans and complete the following:

- 1 Complete** this **Building Guide** by filling in the blanks on page two and three, and indicating which construction details will be used.
- 2 Provide 2 Plot Plans** (**site plan**) showing dimensions of your project or addition and its relationship to existing buildings or structures on the property and the distance to existing property lines, drawn to scale.
- 3 Fill out a building permit application.**

The majority of permit applications are processed with little delay. The submitted documents will help determine if the project is in compliance with building safety codes, zoning ordinances and other applicable laws.

The Colorado Chapter of the International Code Council is a professional organization seeking to promote the public health, safety and welfare to building construction. We appreciate your feedback and suggestions. To obtain a master copy of this building guide, please write to the Colorado Chapter of the International Code Council. P.O. Box 961, Arvada, CO 80001.
<http://www.coloradochaptericc.org>

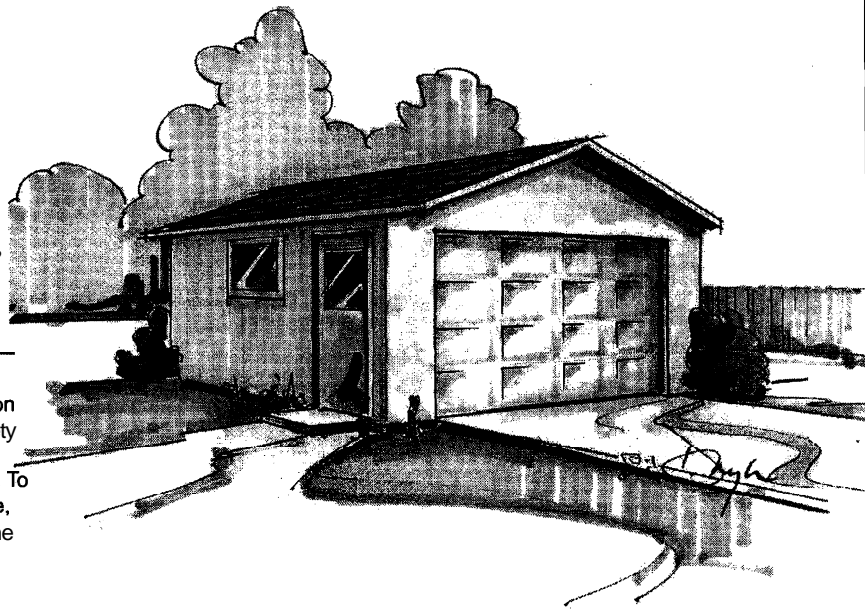

This handout was developed by the Colorado Chapter of the International Code Council as a basic plan submittal under the 2006 International Residential Code. It is not intended to cover all circumstances. Check with your Department of Building Safety for additional requirements.



City of Greeley
Building Inspection Division
1100 10th Street, Suite 114
Greeley, CO 80631

Single Family Residential One Story Detached Garage

Directions

- Fill in the blanks on pages 2 and 3 with dimensions and materials which will be used to build the structure. Please print legibly.

Address: _____

- Indicate in the check boxes on page 3 which detail from page 4 will be used.

Note: Heated garages may require special provisions.

Floor Plan

Dimension _____

Locate and detail bracing

Indicate rafter or truss direction

Check one

Garage is heated

Garage is not heated

Show door and window header sizes and location and size of landing in front of door

3 1/2" minimum concrete slab

Floor slope

() X header
(example (2) 2 x 10)

Note:
If roof trusses or rafters bear on header, special header design may be required

Double 2x4 or 2x6 trimmers each end of overhead door header

Garage door opening

Dimension _____

Garage door opening width _____

Dimension* _____

Dimension* _____

* See Braced Wall Panel Detail on page 4 to comply with section R602.10.6.2 (IRC)

This handout was developed by the Colorado Chapter of the International Code Council as a basic plan submittal under the 2006 International Residential Code. It is not intended to cover all circumstances. Check with your Department of Building Safety for additional requirements.

Greeley
Colorado
From the Ground Up

City of Greeley
Building Inspection Division
1100 10th street, Suite 114
Greeley, CO 80631

Single Family Residential One Story Detached Garage

Note: For roofs with slopes less than 4:12, follow manufacturer's instructions for low slope application of roofing material.

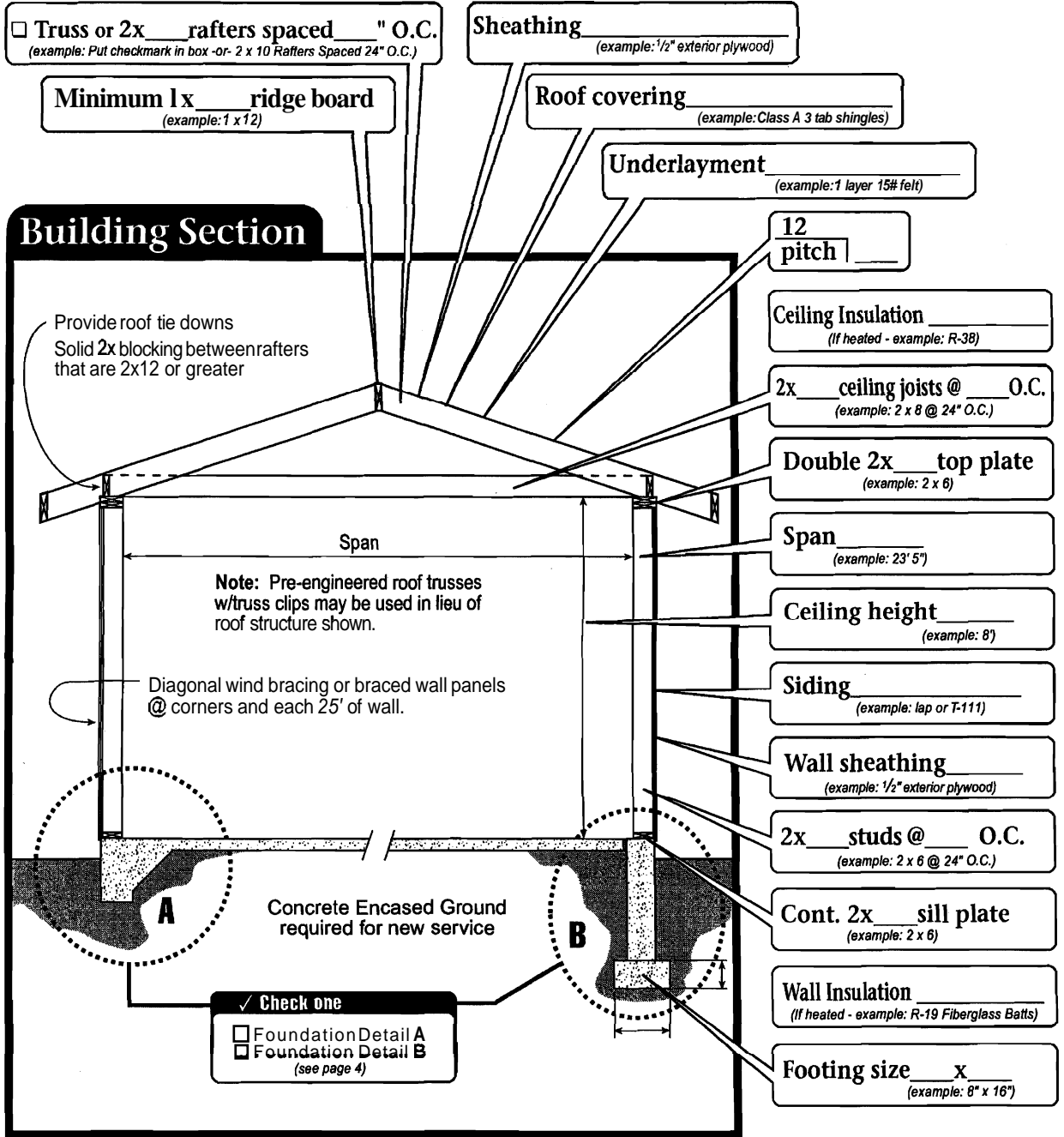

This handout was developed by the Colorado Chapter of the International Code Council as a basic plan submittal under the 2006 International Residential Code. It is not intended to cover all circumstances. Check with your Department of Building Safety for additional requirements.



City of Greeley
Building Inspection Division
1100 10th Street, Suite 114
Greeley, CO 80631

Single Family Residential One Story Detached Garage

Foundation Detail A

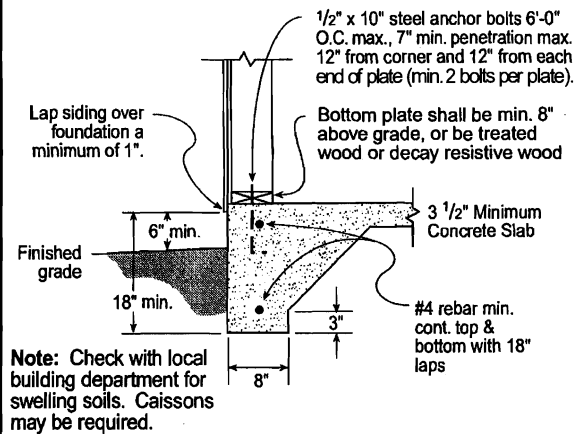

Foundation Detail B

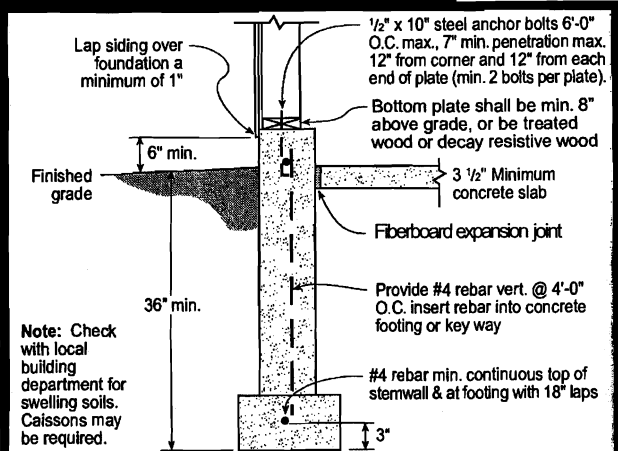

Braced Wall Panel Detail

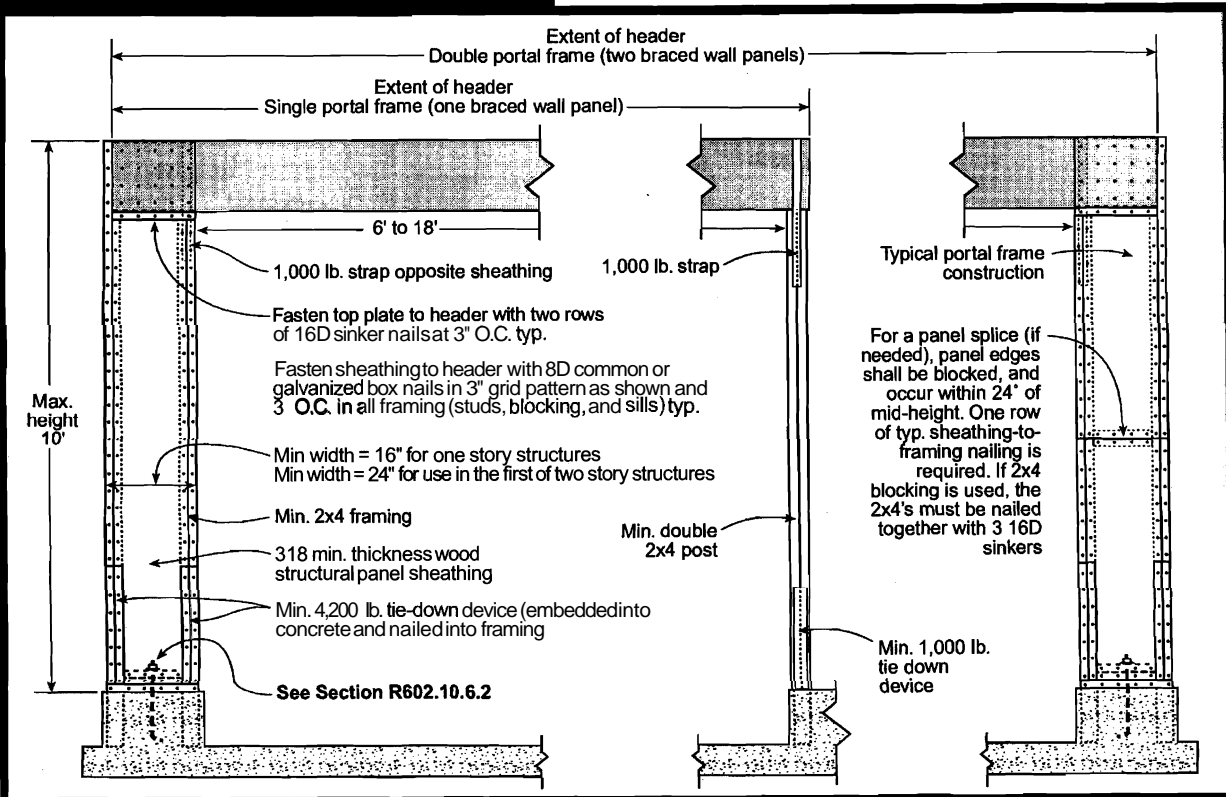

This handout was developed by the Colorado Chapter of the International Code Council as a basic plan submittal under the 2006 International Residential Code. It is not intended to cover all circumstances. Check with your Department of Building Safety for additional requirements.



City of Greeley
Building Inspection Division
1100 10th Street, Suite 114
Greeley, CO 80631



Additions

Owner _____

Address _____ Telephone _____

Zoning of Property _____

Prior to application to the Building Inspection Division for a building permit for An addition, please provide the following information to the Planning Division, For review and approval: (Property owner must sign and initial)

1. Site plan, drawn to scale, which shows:
 - A. Location of the proposed addition relative to property lines.
 - B. Footprint of the principal building, including the garage.
 - C. Lot coverage, percent of building coverage, percent of landscaping coverage, percent of area covered in a hard surface.
 (See sample site plan on the back of this sheet.)

2. Building elevations, drawn to scale, which shows:
 - A. The existing structure.
 - B. All sides of the addition.
 - C. Proposed exterior materials and colors.

3. For additions, indicate your intent to comply with the following by placing your initials on the line provided:
 - ___ A. The proposed addition will have a point of attachment constituting a minimum of 20% of the circumference of the exterior walls of the addition.
 - ___ B. The maximum height of the addition shall be limited to 150% of the average height of the existing principal structures on the block face.
 - ___ C. The maximum length and width of an addition shall be limited to 150% of the average length and width of perimeter walls of the existing principal structures on the block face.
 - ___ D. The addition will be constructed of similar materials and in a similar design as the principal structure.

4. For patio covers, carports, decks, **and/or** porches, indicate your intent to comply with the following by placing your initials on the line provided:
 - ___ A. Porches and patios attached to the principal building, whether or not covered by roofs, may extend to within 10' of the front property line, provided that such remain at least 65% open and unobstructed on three sides.
 - ___ B. Patio covers, carports, decks, **and/or** porches may extend into the rear setback to within 5', provided that such shall remain at least 65% open and unobstructed on three sides.
 - ___ C. Uncovered porches and patios shall be permitted within required interior side yard setbacks.

This is to certify that I/we have read and understand the conditions of the Greeley Development Code concerning additions I/we agree to abide by the conditions stated herein.

Property Owner's Signature

Date _____

Reviewed for Zoning Compliance by

Date _____

(See reverse side for any additional comments)

Comments: _____

EXAMPLE

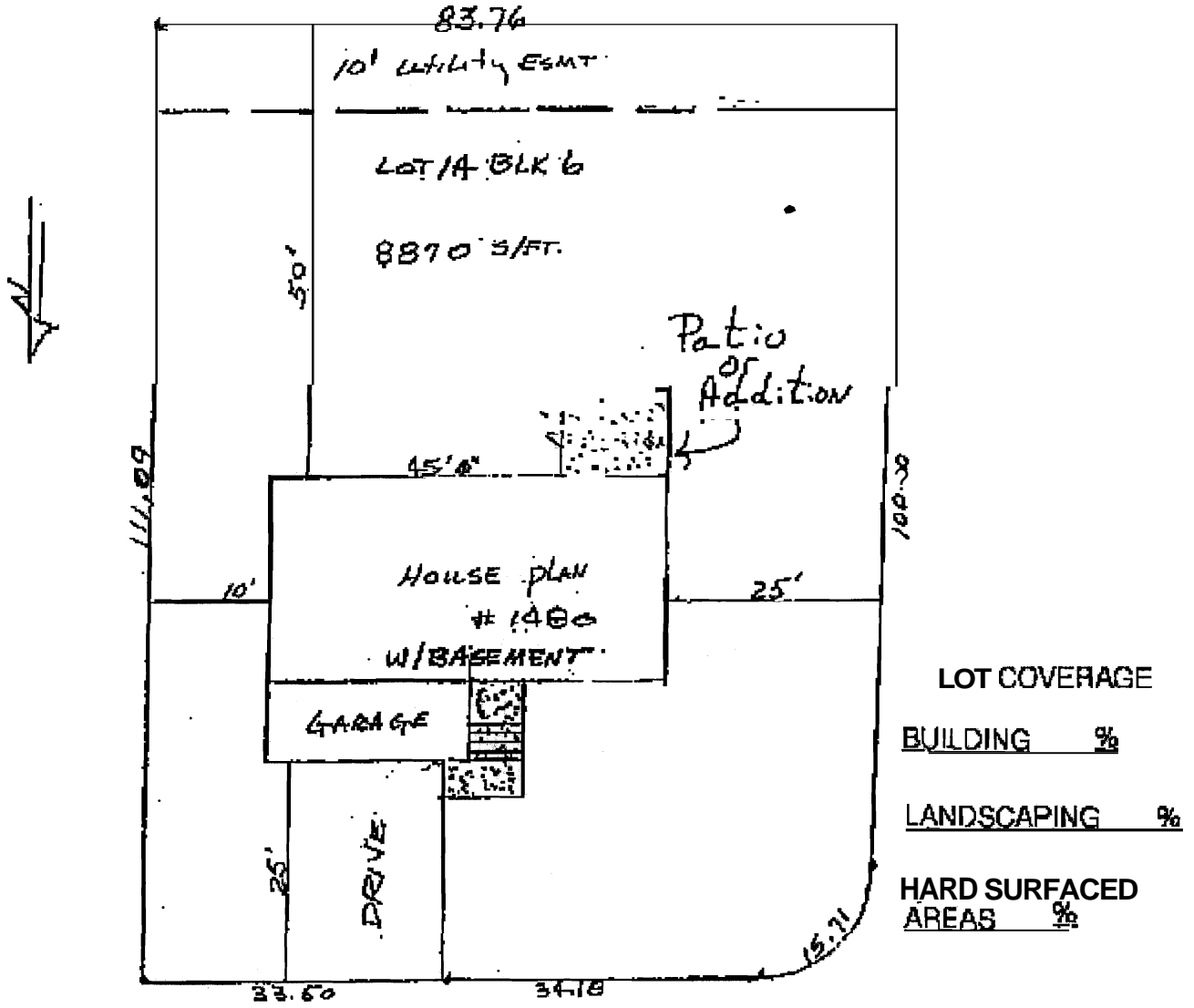

Scale 1" = 20'

SITE PLAN