

**CITY OF GREELEY
INVITATION FOR BID**

2021 Infrastructure Improvement Program

BID #FD21-07-151

DUE AUGUST 6, 2021 BEFORE 2:00 P.M.



Serving Our
Community
It's A Tradition

The Office of the Purchasing Manager is a service division established to build effective partnerships through efficient and responsive procurement processes to obtain high quality goods and services for the best value.

**SECTION 00110
BID #FD21-07-151**

INVITATION FOR BID

The City of Greeley, Colorado is issuing an Invitation to Bid for the 2021 Infrastructure Improvement Program for bids to be received on **August 6, 2021 before 2:00 pm** via electronic submission. A Zoom Meeting will be held at which time all bids will be publicly opened and read aloud.

Federal Section 3 requirements for opportunities for low-moderate-income residents and businesses will apply. The City of Greeley is issuing this Invitation to Bid for a project with Community Development Block Grant funding. Certified Section 3 business concerns are encouraged to submit a bid. To certify as a Section 3 business, one or more of the following must apply:

- *Business is a Section 3 resident-owned business (51% of ownership must qualify and be certified as a Section 3 resident. A Section 3 resident either resides in public housing or has a household income of 80% or less than the Area Median Income).*
- *Business will subcontract 25% of the funds awarded to a qualified Section 3 Business(es).*
- *Certify that 30% of the business's work force is currently Section 3 residents or were Section 3 eligible residents within three years of the date of first employment.*

Businesses meeting one of the above qualifications may also certify as a Section 3 business for purposes of subcontracting on the project.

Employment opportunities at the project site may also be available to City of Greeley residents who qualify as a Section 3 resident. To certify as a Section 3 resident, one or more of the following must apply:

- *Public housing resident*
- *Household has gross income of 80% or less of the Area Median Income*
- *Additional preference may be given to a resident of the project service area*

Certification as a Section 3 resident or business concern is not a guarantee of work.

Minority and/or Women Owned Businesses are also encouraged to submit a bid.

Information on Section 3 and information on how to certify as a business concern to submit a bid, certify as a business concern interested in subcontracting on the project, or certify as a City of Greeley Section 3 resident is available by contacting the Greeley Urban Renewal Authority – 970.350.9380.

The City of Greeley disseminates all bids and requests for proposals through the Rocky Mountain Online Bid System site. Go to <http://www.RockyMountainBidSystem.com>, then "Bid Opportunities" and then select "The City of Greeley." Bids submitted to the City of Greeley **must include** Sections 00120, 00130, 00140 and 00360. Addenda must be acknowledged in Section 00120 of the bidding documents. Bidders failing to acknowledge any and all addenda may be considered non-responsive.

A pre-bid meeting will be held on July 22, 2021 at 1:00 p.m. as a virtual meeting. All interested vendors are highly encouraged to attend.

Invitation to a scheduled ZOOM meeting.

Join Zoom Meeting

<https://greeleygov.zoom.us/j/87832719142>

Meeting ID: 878 3271 9142

Passcode: 923001

Dial by your location

+1 312 626 6799 US (Chicago)

+1 346 248 7799 US (Houston)

+1 669 900 6833 US (San Jose)

Each bid shall be accompanied by a certified check drawn on a bank which is insured by the Federal Deposit Insurance corporation or a bidder's bond executed by a surety company authorized to do business in Colorado, made payable to the City of Greeley, Colorado, in an amount not less than five percent (5%) of the proposal sum as security that the successful bidder will enter into a contract to construct this project in accordance with the plans and specifications, and give bonds in the sum as hereafter provided. Checks accompanying bids not accepted will be returned.

The successful responsive and responsible bidder will be required to furnish a satisfactory performance bond and payment bond in the amount of the contract sum.

No bids shall be withdrawn for a period of sixty (60) days after bid opening.

The City of Greeley retains the right to reject any and all bids and to waive any informality as deemed in the best interest of the city.

Questions pertaining to the solicitation may be directed to Linda Ingram via email: purchasing@greeleygov.com. Deadline to receive questions is **July 26, 2021** by 4:00pm.

City of Greeley, Colorado
Douglas Clapp
Purchasing Manager

Greeley Tribune

*"Public Viewing Copy: The City is a governmental entity subject to the Colorado Open Records Act, C.R.S. §§ 24-72-200.1 et seq. ("CORA"). Any bids/proposals submitted hereunder are subject to public disclosure by the City pursuant to CORA and City ordinances. Vendors may submit one (1) additional complete bid/proposal clearly marked "FOR PUBLIC VIEWING." In this version of the bid/proposal, the Vendor may redact text and/or data that it deems confidential or proprietary pursuant to CORA. Such statement does not necessarily exempt such documentation from public disclosure if required by CORA, by order of a court of appropriate jurisdiction, or other applicable law. Generally, under CORA trade secrets, confidential commercial and financial data information is not required to be disclosed by the City. Bids/Proposals may not be marked "Confidential" or 'Proprietary' in their entirety. **All provisions of any contract resulting from this request for proposal will be public information.**"*

**SECTION 00115
FEDERAL REQUIREMENTS**

ALSO REFERENCE ATTACHED FEDERAL DOCUMENTS

APPENDIX A, 49 CFR PART 20--CERTIFICATION REGARDING LOBBYING

Certification for Contracts, Grants, Loans, and Cooperative Agreements

(To be submitted with each bid or offer exceeding \$100,000)

The undersigned [Contractor] certifies, to the best of his or her knowledge and belief, that:

- (1) No Federal appropriated funds have been paid or will be paid, by or on behalf of the undersigned, to any person for influencing or attempting to influence an officer or employee of an agency, a Member of Congress, an officer or employee of Congress, or an employee of a Member of Congress in connection with the awarding of any Federal contract, the making of any Federal grant, the making of any Federal loan, the entering into of any cooperative agreement, and the extension, continuation, renewal, amendment, or modification of any Federal contract, grant, loan, or cooperative agreement.
- (2) If any funds other than Federal appropriated funds have been paid or will be paid to any person for making lobbying contacts to an officer or employee of any agency, a Member of Congress, an officer or employee of Congress, or an employee of a Member of Congress in connection with this Federal contract, grant, loan, or cooperative agreement, the undersigned shall complete and submit Standard Form--LLL, "Disclosure Form to Report Lobbying," in accordance with its instructions [as amended by "Government wide Guidance for New Restrictions on Lobbying," 61 Fed. Reg. 1413 (1/19/96). Note: Language in paragraph (2) herein has been modified in accordance with Section 10 of the Lobbying Disclosure Act of 1995 (P.L. 104-65, to be codified at 2 U.S.C. 1601, *et seq.*)]
- (3) The undersigned shall require that the language of this certification be included in the award documents for all subawards at all tiers (including subcontracts, subgrants, and contracts under grants, loans, and cooperative agreements) and that all subrecipients shall certify and disclose accordingly.

This certification is a material representation of fact upon which reliance was placed when this transaction was made or entered into. Submission of this certification is a prerequisite for making or entering into this transaction imposed by 31, U.S.C. § 1352 (as amended by the Lobbying Disclosure Act of 1995). Any person who fails to file the required certification shall be subject to a civil penalty of not less than \$10,000 and not more than \$100,000 for each such failure.

[Note: Pursuant to 31 U.S.C. § 1352(c)(1)-(2)(A), any person who makes a prohibited expenditure or fails to file or amend a required certification or disclosure form shall be subject to a civil penalty of not less than \$10,000 and not more than \$100,000 for each such expenditure or failure.]

The Contractor, _____, certifies or affirms the truthfulness and accuracy of each statement of its certification and disclosure, if any. In addition, the Contractor understands and agrees that the provisions of 31 U.S.C. A 3801, *et seq.*, apply to this certification and disclosure, if any.

_____ Signature of Contractor's Authorized Official

_____ Name and Title of Contractor's Authorized Official

_____ Date

1. BUY AMERICA REQUIREMENTS

(49 U.S.C. 5323(j) 49 CFR Part 661)

Applicability to Contracts

The Buy America requirements apply to the following types of contracts: Construction Contracts and Acquisition of Goods or Rolling Stock (valued at more than \$100,000).

Flow Down

The Buy America requirements flow down from FTA recipients and subrecipients to first tier contractors, who are responsible for ensuring that lower tier contractors and subcontractors are in compliance. The \$100,000 threshold applies only to the grantee contract, subcontracts under that amount are subject to Buy America.

Mandatory Clause/Language

The Buy America regulation, at 49 CFR 661.13, requires notification of the Buy America requirements in FTA-funded contracts, but does not specify the language to be used. The following language has been developed by FTA.

Buy America - The contractor agrees to comply with 49 U.S.C. 5323(j) and 49 C.F.R. Part 661, which provide that Federal funds may not be obligated unless steel, iron, and manufactured products used in FTA-funded projects are produced in the United States, unless a waiver has been granted by FTA or the product is subject to a general waiver. General waivers are listed in 49 C.F.R. 661.7, and include final assembly in the United States for 15 passenger vans and 15 passenger wagons produced by Chrysler Corporation, and microcomputer equipment and software. Separate requirements for rolling stock are set out at 49 U.S.C. 5323(j)(2)(C) and 49 C.F.R. 661.11. Rolling stock must be assembled in the United States and have a 60 percent domestic content.

A bidder or offeror must submit to the FTA recipient the appropriate Buy America certification (below) with all bids or offers on FTA-funded contracts, except those subject to a general waiver. Bids or offers that are not accompanied by a completed Buy America certification must be rejected as nonresponsive. This requirement does not apply to lower tier subcontractors.

BIDDER MUST SIGN ONE (1) OF THE FOLLOWING:

Certification requirement for procurement of steel, iron, or manufactured products.

Certificate of Compliance with 49 U.S.C. 5323(j)(1)

The bidder or offeror hereby certifies that it will meet the requirements of 49 U.S.C. 5323(j)(1) and the applicable regulations in 49 C.F.R. Part 661.5.

Date _____

Signature _____

Company Name _____

Title _____

Certificate of Non-Compliance with 49 U.S.C. 5323(j)(1)

The bidder or offeror hereby certifies that it cannot comply with the requirements of 49 U.S.C. 5323(j)(1) and 49 C.F.R. 661.5, but it may qualify for an exception pursuant to 49 U.S.C. 5323(j)(2)(A), 5323(j)(2)(B), or 5323(j)(2)(D), and 49 C.F.R. 661.7.

Date

Signature

Company Name

Title

Certification requirement for procurement of buses, other rolling stock and associated equipment.

Certificate of Compliance with 49 U.S.C. 5323(j)(2)(C).

The bidder or offeror hereby certifies that it will comply with the requirements of 49 U.S.C. 5323(j)(2)(C) and the regulations at 49 C.F.R. Part 661.11.

Date

Signature

Company Name

Title

Certificate of Non-Compliance with 49 U.S.C. 5323(j)(2)(C)

The bidder or offeror hereby certifies that it cannot comply with the requirements of 49 U.S.C. 5323(j)(2)(C) and 49 C.F.R. 661.11, but may qualify for an exception pursuant to 49 U.S.C. 5323(j)(2)(A), 5323(j)(2)(B), or 5323(j)(2)(D), and 49 CFR 661.7.

Date

Signature

Company Name

Title

Certificate of Non-Compliance with 49 U.S.C. 5323(j)(1)

The bidder or offeror hereby certifies that it cannot comply with the requirements of 49 U.S.C. 5323(j)(1) and 49 C.F.R. 661.5, but it may qualify for an exception pursuant to 49 U.S.C. 5323(j)(2)(A), 5323(j)(2)(B), or 5323(j)(2)(D), and 49 C.F.R. 661.7.

Date

Signature

Company Name

Title

Certification requirement for procurement of buses, other rolling stock and associated equipment.

Certificate of Compliance with 49 U.S.C. 5323(j)(2)(C).

The bidder or offeror hereby certifies that it will comply with the requirements of 49 U.S.C. 5323(j)(2)(C) and the regulations at 49 C.F.R. Part 661.11.

Date

Signature

Company Name

Title

Certificate of Non-Compliance with 49 U.S.C. 5323(j)(2)(C)

The bidder or offeror hereby certifies that it cannot comply with the requirements of 49 U.S.C. 5323(j)(2)(C) and 49 C.F.R. 661.11, but may qualify for an exception pursuant to 49 U.S.C. 5323(j)(2)(A), 5323(j)(2)(B), or 5323(j)(2)(D), and 49 CFR 661.7.

Date

Signature

Company Name

Title

City of Greeley Section 3 Compliance Plan

For Inclusion with Bid Documents, Contracts, and Written Agreements with Contractors



Section 3 Projects/Activities

➤ SUBMIT THIS PAGE (SECTION 3 COMPLIANCE) & REQUIRED FORMS

It is important to understand the information provided to this point. Signature on this page certifies that the information was provided, reviewed, and agreed to by the City Department or other entity entering in a Section 3 covered contract/agreement. The contact information for questions was provided on page one of this document.

Contractor Name: _____ Expected Contract Amt: _____

For this activity, this entity will operate as the (check one of the following):

General Contractor

Address: _____

Contact Person: _____ FAX: _____

Phone Number: _____ Email: _____

Project Name: _____

DUNS Number (required to submit a bid): _____

Registration on sam.gov is completed (required to submit a bid): YES NO

Section 3 Project Type (check one): Housing rehabilitation Housing construction
 Other public construction – infrastructure Other public construction - buildings

Statement of Commitment

By signature at the end of this page, I hereby acknowledge to the City of Greeley, Colorado that I have been duly provided with information regarding the City's Section 3 Program, which explains the obligations and requirements of any Section 3 covered project which, by definition, received funding from the U. S. Department of Housing and Urban Development (HUD).

I certify that I am fully empowered to enter into this Compliance Plan on behalf of the entity for which I am certifying and that the information contained within this Compliance Plan is accurate and correct.

I understand that the City may impose penalties and sanctions for the submission of any false and inaccurate statements within this document or for failing to provide reports or other information in a timely manner.

I understand that the responsibilities of this entity to implement the City's Policies and Procedures are in equal measure to the City and will work together with the City to ensure compliance, to the greatest extent feasible, through the awarding of contracts for work and services to Section 3 business concerns, provide training and employment opportunities to Section 3 residents as noted below, and to submit any required reports or other information in a timely manner.

Signature of Authorized Representative

Date

Signature of Acceptance by City/GURA

Date

➤ SECTION 3 PLAN IMPLEMENTATION RESPONSIBILITIES – CONTRACTORS

- Determine whether your business qualifies as a Section 3 Business Concern. If so, completion of certifying forms is strongly encouraged (see below).

1. INCLUDE WITH BID – Not including all required Section 3 information noted under Item 1 will disqualify the bid (it will not be opened). These requirements pertain only to Section 3; there will be other documents required, as listed in the bid documents, contract, and/or agreement. (Boxes are provided for your convenience to ensure all required forms are attached. Not checking the box will not disqualify the bid if the forms are attached. Forms are provided.)

- Completed Compliance Plan form (Page 1). This document will be part of the contract or written Agreement with a City Department/Division, GURA, a City of Greeley Subrecipient, or Developer.

REMINDER: A DUNS Number and registration is required for all contractors and subcontractors and must be noted on the first page of the Plan.

- Contracting Plan Worksheet/Estimated Work Force Needed Worksheet
- Permanent Employee List (needed at bid and again at project completion to determine if there were new hires)
- Plan to Meet Goals for Hiring Section 3 Businesses and Residents. This form needs to state how you will advertise the potential availability of employment opportunities. Suggestions include posting at the Housing Authority, library, social services, and/or other places frequented by low- moderate income persons; website ads; printed ads; etc.

OPTIONAL (BUT STRONGLY ENCOURAGED) – CERTIFY YOUR BUSINESS AS A SECTION 3 BUSINESS

- Certification for Business Concerns form and documentation noted on the form
- Certification for Residents – one form for each active employee - (form only) to verify eligibility as a Section 3 Business Concern (Contractor/Subcontractor is responsible for maintaining documentation from employees)

2. DURING THE ACTIVITY/PROJECT

- Provide Subcontractors with the Compliance Plan and Implementing Forms for Subcontractors, and have them complete them as noted on the Subcontractor Plan. It becomes a part of the Contractor's contract with the Subcontractors (that meet the Section 3 Project/Activity funding level).
- Include the Section 3 Contract Clause (provided with the forms at the end of this document) in all bid documents and contracts with Subcontractors.

IF THERE ARE NEW HIRES BY THE CONTRACTOR THAT QUALIFY AS SECTION 3 RESIDENTS

- Certification for Residents – one form for each new hire. Provide Contractor with the form only – Subcontractor maintains backup documentation; Contractor shall provide information to GURA.

IF SUBCONTRACTING WITH A BUSINESS CONCERN THAT QUALIFIES AS A SECTION 3 BUSINESS CONCERN

- Certification for Business Concerns form (provide to GURA or the Project Manager) and documentation noted on the form (maintain with Contractor files and make available on request.)
- Certification for Residents – one form for each current employee – (form only to GURA or Project Manager) to verify eligibility as a Section 3 Business Concern. (Contractor is responsible for maintaining back-up documentation on its employees, to be made available on request.)

- Coordinate with GURA or Project Manager to make the Section 3 Plan and Implementing Forms for Subcontractors a part of any Section 3 contract or subcontract entered into. The Compliance Plan for Subcontractors is available for review from GURA on request.
- Provide the reports requested to GURA or the Project manager in a timely manner.
- Follow the procedures for Contractors as outlined in the Guidebook

3. AT PROJECT COMPLETION the following must be provided to GURA or the Project Manager:

- Current Employee List (as of the end of the Project/Activity).
- List of New Hires during the Project, (should be the employee difference between the initial Permanent Employee List and end of project/activity Permanent Employee List), and List of New Hires Trained.

Other information may be required for the City to complete its Section 3 reporting requirements. Contractors shall fully cooperate with the City in providing required reports needed to comply with Section 3. Failure to provide these documents in a timely manner could result in payment delays and more seriously, other sanctions against the business concern.

FORMS FOLLOW

FORMS REQUIRED WITH BIDS

1. All forms in this section must be submitted with bid documents.
2. If qualified as a Section 3 business concern, it is strongly recommended that the certification forms (business and residents to qualify the business) be submitted with bid or within five days of bid award. The City is expected to meet the stated goals; other parties are expected to assist the City.

CONTRACTING PLAN AND ESTIMATED WORKFORCE NEEDED FOR THIS ACTIVITY

Name of Company/City Department						
Project Name						
	(1)	(2)	(3)	(4)	(5)	(6)
Job Category	Construction or Professional (C or P)	Total Estimated Positions Needed for Activity	# of Positions Occupied by Permanent Employees	Number of Positions Not Occupied	# of Positions to be filled with Section 3 Residents	Total Estimated Contract for Each Trade
Skilled						
Semi-skilled						
Skilled trainees						
Unskilled trainees						
Semi-skilled trainees						
Professional & Administrative						
Clerical						
Apprentices						
Other						

This form compares current work force with the anticipated workforce needed to complete the contract on which the bid is being placed. Form must be completed.

- (1) Note whether job category is a construction (C) or professional (P) category.
- (2) Estimate the total number of positions that will be needed for each category to complete this activity, current work force included.
- (3) By job category, enter the number of current employees. (These employees must be listed by name on the **Permanent Employee List** form).
- (4) By job category, enter the number of employees you estimate you will need to complete this activity (# in box 2 minus # is box 3).
- (5) Of the number identified in column 4, estimate how many of those you can fill with Section 3 residents. Your goal should be no less than 30% of any **new hires** will be Section 3 residents.
- (6) If you need to contract outside your company, state the estimated dollar amount by job category.

If no recruitment or hiring is anticipated, explain why: _____

PLAN TO MEET GOALS FOR HIRING SECTION 3 BUSINESSES AND RESIDENTS

Indicate the efforts that will be made to notify Section 3 BUSINESS CONCERNS, AND RESIDENTS, IF THERE WILL BE NEW HIRES, of contracting opportunities generated by HUD financial assistance for housing and community development programs, to the greatest extent feasible (use additional pages if necessary). **All efforts must be documented** (i.e. ad copies, photo of postings, etc). At project completion, attach copies of all publications, notices, pictures of posted notices, and any other outreach material utilized, along with a list of all Section 3 business concerns and/or Section 3 residents that responded to your outreach efforts. Submit copies to GURA.

➤ **OUTREACH TO SOLICIT BIDS FROM SECTION 3 BUSINESSES**

Recipient/Subrecipient/General Contractor/Subcontractor: _____

Project Name: _____

Period Covered: _____

Date Submitted: _____

Job availability will be posted at Housing Authority with Section 3 language

Job availability will be advertised in the Greeley Tribune with Section 3 language

Job availability will be posted in low- moderate-income neighborhood locations

Other – list below

➤ **OUTREACH TO SOLICIT BIDS FROM SECTION 3 RESIDENTS**

FORMS REQUIRED AT PROJECT/ACTIVITY COMPLETION

1. Prior to receiving final payment, the Permanent Employee List must be submitted to the Project Manager or GURA, and
2. **If there were new hires** during the project/activity, also submit
 - a. “New Hires During Activity/Project” and Section 3 New Hires Trained during Project/Activity” forms (as applicable), and
 - b. Residents’ certification form only. (Backup documentation shall be kept by the Subcontractor and made available on request).
3. Attach copies of all publications, notices, pictures of posted notices, employment ads, website ads, and any other outreach material utilized during the hiring process as noted on the “Plan to Meet Goals for Hiring Section 3 Businesses and Residents” submitted at time of bid.
4. Business Concerns certification forms, including Resident certifications to qualify the Business Concern (if subcontracting was with a Section 3 Business Concern and they opted to complete the forms).

PERMANENT EMPLOYEE LIST – PROJECT COMPLETION

Name of Company/City Department	
Project Name	

Name of Employee	Job Category

NEW HIRES DURING ACTIVITY/PROJECT

For this activity, this entity will operate as the (check one of the following):

- Subrecipient
 (Owner/Developer)
 (General Contractor)
 (Subcontractor)

Name of Company	
Project Name	
Period Covered	
Date Submitted	

Employee Name	Last 4 Digits SS#	Position	Length of Employment by Dates		Length of Employment in Hours		Check if Section 3 New Hire	Check if Non-Section 3 New Hire
			Start	End	Proposed	Actual		

SECTION 3 NEW HIRES TRAINED DURING PROJECT/ACTIVITY

For this activity, this entity will operate as the (check one of the following):

- Subrecipient
 Owner/Developer
 General Contractor
 Subcontractor

Name of Company	
Project Name	
Period Covered	
Date Submitted	

Employee Name:	Last 4 digits of SS#:
Position:	
Type of Training Provided:	

Employee Name:	Last 4 digits of SS#:
Position:	
Type of Training Provided:	

Employee Name:	Last 4 digits of SS#:
Position:	
Type of Training Provided:	

Employee Name:	Last 4 digits of SS#:
Position:	
Type of Training Provided:	

SECTION 3 CERTIFICATION FORMS

1. Businesses concerns certifying to Section 3 status submit:
 - a. Certification for Business Concerns
 - b. Resident certification for each employee (to show business concern Section 3 qualification)
2. **If there were new hires** submit resident certification form for any Section 3 resident as noted on the New Hires form.

CERTIFICATION FOR BUSINESS CONCERNS

Name of Business _____

Address of Business _____

Type of Business: Corporation Partnership Sole Proprietorship Joint Venture

Income Limits (gross household income from all occupants cannot exceed the noted amounts to qualify as a Section 3 resident).

- **Contact GURA for most current income limits**

Resident must also reside within the City of Greeley to be considered a Section 3 resident for this project.

For business entity, as applicable, provide:

- | | |
|--|---|
| <input type="checkbox"/> Copy of Article of Incorporation | <input type="checkbox"/> Certificate of Good Standing |
| <input type="checkbox"/> Assumed Business Name Certificate | <input type="checkbox"/> Partnership Agreement |
| <input type="checkbox"/> List of owners/stockholders and % ownership of each | <input type="checkbox"/> Corporation Annual Report |
| <input type="checkbox"/> Organization chart with names and titles and brief function statement | <input type="checkbox"/> Latest Board minutes appointing officers |
| <input type="checkbox"/> Additional documentation | |

Check appropriate category – A, B, or C and attach the appropriate documentation as evidence of status:

Warning: Title 18, Section 1001 of the U. S. Code states that a person is guilty of a felony for knowingly and willingly making false or fraudulent statements to any department of the United States Government.

A. For business claiming status as a Section 3 resident-owned enterprise check here:

Owner's Name, Title, and Address	Ownership %	Housing Authority Resident	Section 3 Resident of City of Greeley
		<input type="checkbox"/>	<input type="checkbox"/>
		<input type="checkbox"/>	<input type="checkbox"/>
		<input type="checkbox"/>	<input type="checkbox"/>
		<input type="checkbox"/>	<input type="checkbox"/>
		<input type="checkbox"/>	<input type="checkbox"/>

And provide the following:

- | | |
|--|---|
| <input type="checkbox"/> Copy of resident lease | <input type="checkbox"/> Copy of receipt of public assistance |
| <input type="checkbox"/> Copy of evidence of participation in a public assistance program | <input type="checkbox"/> Other evidence |
| <input type="checkbox"/> Provide Section 3 Resident certification for each qualifying resident | |

B. For business claiming Section 3 status by subcontracting 25 percent of the dollar awarded to qualified Section 3 business, check here:

And provide the following information (add additional pages, if necessary):

Project Name	Project Address	Total Contract
Section 3 Subcontractor	Contract Amount	Project Percentage

Provide Section 3 Business certification for each qualifying subcontractor.

C. For business claiming Section 3 status, claiming at least 30 percent of their workforce are currently Section 3 residents or were Section 3 eligible residents within 3 years of date of first employment with the business, check here:

And provide the following information for all current employees, noting if they meet Section 3 qualifications:

Employee	Position	FTE/PTE	Greeley Housing Authority Resident	Section 3 Resident of City of Greeley
			<input type="checkbox"/>	<input type="checkbox"/>
			<input type="checkbox"/>	<input type="checkbox"/>
			<input type="checkbox"/>	<input type="checkbox"/>
			<input type="checkbox"/>	<input type="checkbox"/>
			<input type="checkbox"/>	<input type="checkbox"/>
			<input type="checkbox"/>	<input type="checkbox"/>
			<input type="checkbox"/>	<input type="checkbox"/>

And provide the following for any employee for which Section 3 status is claimed:

- PHA/IHA Residential lease less than 3 years from day of employment
- Other evidence of Section 3 status less than 3 years from date of employment
- Provide Section 3 Resident certification for each qualifying resident

D. Evidence of ability to perform successfully under the terms and conditions of the proposed contract:

- Current financial statement
- Statement of ability to comply with public policy
- List of owned equipment
- List of all contracts for the past two years

I certify that to the best of my knowledge the above statements and the documentation provided are true.

Printed Name: _____

Signature: _____

Title: _____

Date: _____

Acceptance for the City of Greeley

Signature: _____

Title: _____

Dept./Division: _____

Date: _____

CERTIFICATION FOR SECTION 3 RESIDENT

- USE:**
- 1. **Business concerns** certifying the entity is a Section 3 business must have all employees complete this form and provide the noted documentation.
 - 2. **New hires or new trainees** – To certify a new hire is a Section 3 resident, this form must be completed by the new hire with documentation noted provided.

This form and the documentation must be retained by the business concern for a period of five years following the end of the contract. Submit this form only to GURA, unless requested to provide all documentation.

A Section 3 resident seeking employment and/or training as provided for under Section 3 shall certify and submit evidence to the recipient (GURA), contractor, or subcontractor, as requested, that the person is a Section 3 resident. Please note below how you believe you're eligible for Section 3 preference and provide a photo ID and proof of current residency. Incomes are based on the entire household's income, not just the person being hired.

- I am a resident of public housing
 Based on the chart below, I am a low-income resident of Greeley
Contact GURA for most current income limits

- I reside in the project neighborhood (Business concerns may or may not provide a preference)

Certification for Resident Seeking Section 3 Status for Employment and Training

I, _____, am a legal resident of the City of Greeley, Colorado and the United States of America and meet the income eligibility guidelines for a low- or very-low-income person as published above.

My permanent address is: _____

I have attached the following documentation as evidence of my status:

- Copy of Greeley Housing Authority lease
 Copy of receipt of public assistance
 Copy of Evidence of participation
 in a public assistance program
 Other evidence (name on line below) _____

- I do not qualify as a Section 3 resident (complete signature/date lines below)
 I decline to release the required information and make no statement as to section 3 resident qualification (complete signature/date lines below)

_____ Printed Name

_____ Date

Accepted on behalf of the

- City of Greeley
 General Contractor
 Subcontractor

_____ Signature and Title

_____ Department

_____ Printed Name

_____ Date

**SECTION 3 CLAUSE
AND
SAMPLE ADS**

SECTION 00115 continued
(SECTION 3 CONTRACT CLAUSE)

(To be included in all bid documents and contracts)

All Section 3 covered contracts shall include the following clause (referred to as the Section 3 clause):

- A. The work to be performed under this contract is subject to the requirements of Section 3 of the Housing and Urban Development Act of 1968, as amended, 12 U.S.C. 1701u (Section 3). The purpose of Section 3 is to ensure that employment and other economic opportunities generated by HUD assistance or HUD-assisted projects covered by Section 3, shall, to the greatest extent feasible, be directed to low- and very low-income persons, particularly persons who are recipients of HUD assistance for housing.
 - B. The parties to this contract agree to comply with HUD's regulations in 24 CFR Part 135, which implement Section 3. As evidenced by their execution of this contract, the parties to this contract certify that they are under no contractual or other impediment that would prevent them from complying with the Part 135 regulations.
 - C. The contractor agrees to send to each labor organization or representative of workers with which the contractor has a collective bargaining agreement or other understanding, if any, a notice advising the labor organization or workers' representative of the contractor's commitments under this Section 3 clause, and will post copies of the notice in conspicuous places at the work site where both employees and applicants for training and employment positions can see the notice. The notice shall describe the Section 3 preference, shall set forth minimum number and job titles subject to hire, availability of apprenticeship and training positions, the qualifications for each; and the name and location of the person(s) taking applications for each of the positions; and the anticipated date the work shall begin. (Note: GURA understands that posting on a job site may not always be practicable. The expectation for the City of Greeley is that job site posting be done whenever feasible, and if not feasible, the posting shall be at the contractor's or subcontractor's local office.)
 - D. The contractor agrees to include this Section 3 clause in every sub-contract subject to compliance with regulations in 24 CFR part 135, and agrees to take appropriate action, as provided in an applicable provision of the subcontractor in this Section 3 clause, upon a finding that the subcontractor is in violation of the regulations in 24 CFR Part 135. The contractor will not sub-contract with any subcontractor where the contractor has notice or knowledge that the subcontractor has been found in violation of the regulations in 24 CFR Part 135.
 - E. The contractor will certify that any vacant employment positions, including training positions, that are filled (1) after the contractor is selected but before the contract is executed, and (2) with persons other than those to whom the regulations of 24 CFR Part 135 require employment opportunities to be directed, were not filled to circumvent the contractor's obligations under 24 CFR Part 135.
 - F. Non-compliance with HUD's regulations in 24 CFR Part 135 may result in sanctions, termination of this contract for default, and debarment or suspension from future HUD-assisted contracts.
 - G. (This section pertains to work performed in connection with Section 3 covered Indian housing assistance, Section 7(b) of the Indian Self-Determination and Education Assistance Act (25 U.S.C. 450e) and is not applicable in the City of Greeley.)
-



Invitation to Bid/Possible Employment Opportunity

The City of Greeley (OR INSERT CONTRACTOR NAME) will be accepting bids through _____ for an infrastructure project/activity (OR INSERT OTHER PROJECT/ACTIVITY TYPE) funded in part with Community Development Block Grant funding. Certified Section 3 business concerns are strongly encouraged to certify as a Section 3 business concern and submit a bid (although the City does not give a preference to a Section 3 business concern).

To certify as a Section 3 business concern, one or more of the following must apply:

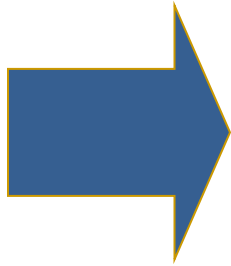

- Business is a Section 3 resident-owned business (51% of ownership must qualify and be certified as a Section 3 resident. A Section 3 resident either resides in public housing or has a household income of 80% or less than the Area Median Income).
- Business will subcontract 25% of the funds awarded to a qualified Section 3 Business(es).
- Certify that 30% of the business's work force is currently Section 3 residents or were Section 3 eligible residents within three years of the date of first employment.

Business concerns meeting one of the above qualifications may also certify as a Section 3 business for purposes of subcontracting. Minority and Women Owned Businesses are also encouraged to submit a bid.

Employment opportunities at the project site may also be available to City of Greeley residents who qualify as a Section 3 resident. To certify as a Section 3 resident, one or more of the following must apply:

- Public housing resident
- Household has gross income of 80% or less of the Area Median Income
- Additional preference may be given to a resident of the project service area

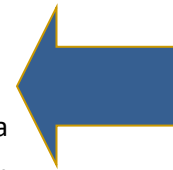

Information on how to certify as a business concern to submit a bid, a business interested in subcontracting, or a City of Greeley resident wanting to certify as a Section 3 resident and other Section 3 information is available by contacting the Greeley Urban Renewal Authority – 970.350.9380.

Questions on the Invitation to Bid should be directed to the Greeley Urban Renewal Authority – 970-350-9380 or (INSERT CITY DEPARTMENT OR CONTRACTOR NAME AND CONTACT INFORMATION).

This posting does not guarantee employment opportunities will be available, and certification as a Section 3 resident or business concern is not a guarantee of work.



Applicability

The Project or Program to which the construction work covered by this contract pertains is being assisted by the United States of America and the following Federal Labor Standards Provisions are included in this Contract pursuant to the provisions applicable to such Federal assistance.

A. 1. (i) Minimum Wages. All laborers and mechanics employed or working upon the site of the work, will be paid unconditionally and not less often than once a week, and without subsequent deduction or rebate on any account (except such payroll deductions as are permitted by regulations issued by the Secretary of Labor under the Copeland Act (29 CFR Part 3), the full amount of wages and bona fide fringe benefits (or cash equivalents thereof) due at time of payment computed at rates not less than those contained in the wage determination of the Secretary of Labor which is attached hereto and made a part hereof, regardless of any contractual relationship which may be alleged to exist between the contractor and such laborers and mechanics. Contributions made or costs reasonably anticipated for bona fide fringe benefits under Section I(b)(2) of the Davis-Bacon Act on behalf of laborers or mechanics are considered wages paid to such laborers or mechanics, subject to the provisions of 29 CFR 5.5(a)(1)(iv); also, regular contributions made or costs incurred for more than a weekly period (but not less often than quarterly) under plans, funds, or programs, which cover the particular weekly period, are deemed to be constructively made or incurred during such weekly period. Such laborers and mechanics shall be paid the appropriate wage rate and fringe benefits on the wage determination for the classification of work actually performed, without regard to skill, except as provided in 29 CFR 5.5(a)(4). Laborers or mechanics performing work in more than one classification may be compensated at the rate specified for each classification for the time actually worked therein: Provided, That the employer's payroll records accurately set forth the time spent in each classification in which work is performed. The wage determination (including any additional classification and wage rates conformed under 29 CFR 5.5(a)(1)(ii) and the Davis-Bacon poster (WH-1321) shall be posted at all times by the contractor and its subcontractors at the site of the work in a prominent and accessible, place where it can be easily seen by the workers.

(ii) (a) Any class of laborers or mechanics which is not listed in the wage determination and which is to be employed under the contract shall be classified in conformance with the wage determination. HUD shall approve an additional classification and wage rate and fringe benefits therefor only when the following criteria have been met:

(1) The work to be performed by the classification requested is not performed by a classification in the wage determination; and

(2) The classification is utilized in the area by the construction industry; and

(3) The proposed wage rate, including any bona fide fringe benefits, bears a reasonable relationship to the wage rates contained in the wage determination.

(b) If the contractor and the laborers and mechanics to be employed in the classification (if known), or their representatives, and HUD or its designee agree on the classification and wage rate (including the amount designated for fringe benefits where appropriate), a report of the action taken shall be sent by HUD or its designee to the Administrator of the Wage and Hour Division, Employment Standards Administration, U.S. Department of Labor, Washington, D.C. 20210. The Administrator, or an authorized representative, will approve, modify, or disapprove every additional classification action within 30 days of receipt and so advise HUD or its designee or will notify HUD or its designee within the 30-day period that additional time is necessary. (Approved by the Office of Management and Budget under OMB control number 1215-0140.)

(c) In the event the contractor, the laborers or mechanics to be employed in the classification or their representatives, and HUD or its designee do not agree on the proposed classification and wage rate (including the amount designated for fringe benefits, where appropriate), HUD or its designee shall refer the questions, including the views of all interested parties and the recommendation of HUD or its designee, to the Administrator for determination. The Administrator, or an authorized representative, will issue a determination within 30 days of receipt and so advise HUD or its designee or will notify HUD or its designee within the 30-day period that additional time is necessary. (Approved by the Office of Management and Budget under OMB Control Number 1215-0140.)

(d) The wage rate (including fringe benefits where appropriate) determined pursuant to subparagraphs (1)(ii)(b) or (c) of this paragraph, shall be paid to all workers performing work in the classification under this contract from the first day on which work is performed in the classification.

(iii) Whenever the minimum wage rate prescribed in the contract for a class of laborers or mechanics includes a fringe benefit which is not expressed as an hourly rate, the contractor shall either pay the benefit as stated in the wage determination or shall pay another bona fide fringe benefit or an hourly cash equivalent thereof.

(iv) If the contractor does not make payments to a trustee or other third person, the contractor may consider as part

of the wages of any laborer or mechanic the amount of any costs reasonably anticipated in providing bona fide fringe benefits under a plan or program, Provided, That the Secretary of Labor has found, upon the written request of the contractor, that the applicable standards of the Davis-Bacon Act have been met. The Secretary of Labor may require the contractor to set aside in a separate account assets for the meeting of obligations under the plan or program. (Approved by the Office of Management and Budget under OMB Control Number 1215-0140.)

2. Withholding. HUD or its designee shall upon its own action or upon written request of an authorized representative of the Department of Labor withhold or cause to be withheld from the contractor under this contract or any other Federal contract with the same prime contractor, or any other Federally-assisted contract subject to Davis-Bacon prevailing wage requirements, which is held by the same prime contractor so much of the accrued payments or advances as may be considered necessary to pay laborers and mechanics, including apprentices, trainees and helpers, employed by the contractor or any subcontractor the full amount of wages required by the contract. In the event of failure to pay any laborer or mechanic, including any apprentice, trainee or helper, employed or working on the site of the work, all or part of the wages required by the contract, HUD or its designee may, after written notice to the contractor, sponsor, applicant, or owner, take such action as may be necessary to cause the suspension of any further payment, advance, or guarantee of funds until such violations have ceased. HUD or its designee may, after written notice to the contractor, disburse such amounts withheld for and on account of the contractor or subcontractor to the respective employees to whom they are due. The Comptroller General shall make such disbursements in the case of direct Davis-Bacon Act contracts.

3. (i) Payrolls and basic records. Payrolls and basic records relating thereto shall be maintained by the contractor during the course of the work preserved for a period of three years thereafter for all laborers and mechanics working at the site of the work. Such records shall contain the name, address, and social security number of each such worker, his or her correct classification, hourly rates of wages paid (including rates of contributions or costs anticipated for bona fide fringe benefits or cash equivalents thereof of the types described in Section 1(b)(2)(B) of the Davis-bacon Act), daily and weekly number of hours worked, deductions made and actual wages paid. Whenever the Secretary of Labor has found under 29 CFR 5.5 (a)(1)(iv) that the wages of any laborer or mechanic include the amount of any costs reasonably anticipated in providing benefits under a plan or program described in Section 1(b)(2)(B) of the Davis-Bacon Act, the contractor shall maintain records which show that the commitment to provide such benefits is enforceable, that the plan or program is financially responsible, and that the plan or program has been

communicated in writing to the laborers or mechanics affected, and records which show the costs anticipated or the actual cost incurred in providing such benefits. Contractors employing apprentices or trainees under approved programs shall maintain written evidence of the registration of apprenticeship programs and certification of trainee programs, the registration of the apprentices and trainees, and the ratios and wage rates prescribed in the applicable programs. (Approved by the Office of Management and Budget under OMB Control Numbers 1215-0140 and 1215-0017.)

(ii) (a) The contractor shall submit weekly for each week in which any contract work is performed a copy of all payrolls to HUD or its designee if the agency is a party to the contract, but if the agency is not such a party, the contractor will submit the payrolls to the applicant sponsor, or owner, as the case may be, for transmission to HUD or its designee. The payrolls submitted shall set out accurately and completely all of the information required to be maintained under 29 CFR 5.5(a)(3)(i) except that full social security numbers and home addresses shall not be included on weekly transmittals. Instead the payrolls shall only need to include an individually identifying number for each employee (e.g., the last four digits of the employee's social security number). The required weekly payroll information may be submitted in any form desired. Optional Form WH-347 is available for this purpose from the Wage and Hour Division Web site at <http://www.dol.gov/esa/whd/forms/wh347instr.htm> or its successor site. The prime contractor is responsible for the submission of copies of payrolls by all subcontractors. Contractors and subcontractors shall maintain the full social security number and current address of each covered worker, and shall provide them upon request to HUD or its designee if the agency is a party to the contract, but if the agency is not such a party, the contractor will submit the payrolls to the applicant sponsor, or owner, as the case may be, for transmission to HUD or its designee, the contractor, or the Wage and Hour Division of the Department of Labor for purposes of an investigation or audit of compliance with prevailing wage requirements. It is not a violation of this subparagraph for a prime contractor to require a subcontractor to provide addresses and social security numbers to the prime contractor for its own records, without weekly submission to HUD or its designee. (Approved by the Office of Management and Budget under OMB Control Number 1215-0149.)

(b) Each payroll submitted shall be accompanied by a "Statement of Compliance," signed by the contractor or subcontractor or his or her agent who pays or supervises the payment of the persons employed under the contract and shall certify the following:

(1) That the payroll for the payroll period contains the information required to be provided under 29 CFR 5.5 (a)(3)(ii), the appropriate information is being maintained under 29 CFR 5.5(a)(3)(i), and that such information is correct and complete;

(2) That each laborer or mechanic (including each helper, apprentice, and trainee) employed on the contract during the payroll period has been paid the full weekly wages earned, without rebate, either directly or indirectly, and that no deductions have been made either directly or indirectly from the full wages earned, other than permissible deductions as set forth in 29 CFR Part 3;

(3) That each laborer or mechanic has been paid not less than the applicable wage rates and fringe benefits or cash equivalents for the classification of work performed, as specified in the applicable wage determination incorporated into the contract.

(c) The weekly submission of a properly executed certification set forth on the reverse side of Optional Form WH-347 shall satisfy the requirement for submission of the "Statement of Compliance" required by subparagraph A.3.(ii)(b).

(d) The falsification of any of the above certifications may subject the contractor or subcontractor to civil or criminal prosecution under Section 1001 of Title 18 and Section 231 of Title 31 of the United States Code.

(iii) The contractor or subcontractor shall make the records required under subparagraph A.3.(i) available for inspection, copying, or transcription by authorized representatives of HUD or its designee or the Department of Labor, and shall permit such representatives to interview employees during working hours on the job. If the contractor or subcontractor fails to submit the required records or to make them available, HUD or its designee may, after written notice to the contractor, sponsor, applicant or owner, take such action as may be necessary to cause the suspension of any further payment, advance, or guarantee of funds. Furthermore, failure to submit the required records upon request or to make such records available may be grounds for debarment action pursuant to 29 CFR 5.12.

4. Apprentices and Trainees.

(i) **Apprentices.** Apprentices will be permitted to work at less than the predetermined rate for the work they performed when they are employed pursuant to and individually registered in a bona fide apprenticeship program registered with the U.S. Department of Labor, Employment and Training Administration, Office of Apprenticeship Training, Employer and Labor Services, or with a State Apprenticeship Agency recognized by the Office, or if a person is employed in his or her first 90 days of probationary employment as an apprentice in such an apprenticeship program, who is not individually registered in the program, but who has been certified by the Office of Apprenticeship Training, Employer and Labor Services or a State Apprenticeship Agency (where appropriate) to be eligible for probationary employment as an apprentice. The allowable ratio of apprentices to journeymen on the job site in any craft classification shall not be greater than the ratio permitted to the contractor as to the entire work force under the registered program. Any worker listed on a payroll at an apprentice wage rate, who

is not registered or otherwise employed as stated above, shall be paid not less than the applicable wage rate on the wage determination for the classification of work actually performed. In addition, any apprentice performing work on the job site in excess of the ratio permitted under the registered program shall be paid not less than the applicable wage rate on the wage determination for the work actually performed. Where a contractor is performing construction on a project in a locality other than that in which its program is registered, the ratios and wage rates (expressed in percentages of the journeyman's hourly rate) specified in the contractor's or subcontractor's registered program shall be observed. Every apprentice must be paid at not less than the rate specified in the registered program for the apprentice's level of progress, expressed as a percentage of the journeymen hourly rate specified in the applicable wage determination. Apprentices shall be paid fringe benefits in accordance with the provisions of the apprenticeship program. If the apprenticeship program does not specify fringe benefits, apprentices must be paid the full amount of fringe benefits listed on the wage determination for the applicable classification. If the Administrator determines that a different practice prevails for the applicable apprentice classification, fringes shall be paid in accordance with that determination. In the event the Office of Apprenticeship Training, Employer and Labor Services, or a State Apprenticeship Agency recognized by the Office, withdraws approval of an apprenticeship program, the contractor will no longer be permitted to utilize apprentices at less than the applicable predetermined rate for the work performed until an acceptable program is approved.

(ii) **Trainees.** Except as provided in 29 CFR 5.16, trainees will not be permitted to work at less than the predetermined rate for the work performed unless they are employed pursuant to and individually registered in a program which has received prior approval, evidenced by formal certification by the U.S. Department of Labor, Employment and Training Administration. The ratio of trainees to journeymen on the job site shall not be greater than permitted under the plan approved by the Employment and Training Administration. Every trainee must be paid at not less than the rate specified in the approved program for the trainee's level of progress, expressed as a percentage of the journeyman hourly rate specified in the applicable wage determination. Trainees shall be paid fringe benefits in accordance with the provisions of the trainee program. If the trainee program does not mention fringe benefits, trainees shall be paid the full amount of fringe benefits listed on the wage determination unless the Administrator of the Wage and Hour Division determines that there is an apprenticeship program associated with the corresponding journeyman wage rate on the wage determination which provides for less than full fringe benefits for apprentices. Any employee listed on the payroll at a trainee rate who is not registered and participating in a training plan approved by

the Employment and Training Administration shall be paid not less than the applicable wage rate on the wage determination for the work actually performed. In addition, any trainee performing work on the job site in excess of the ratio permitted under the registered program shall be paid not less than the applicable wage rate on the wage determination for the work actually performed. In the event the Employment and Training Administration withdraws approval of a training program, the contractor will no longer be permitted to utilize trainees at less than the applicable predetermined rate for the work performed until an acceptable program is approved.

(iii) Equal employment opportunity. The utilization of apprentices, trainees and journeymen under 29 CFR Part 5 shall be in conformity with the equal employment opportunity requirements of Executive Order 11246, as amended, and 29 CFR Part 30.

5. Compliance with Copeland Act requirements. The contractor shall comply with the requirements of 29 CFR Part 3 which are incorporated by reference in this contract

6. Subcontracts. The contractor or subcontractor will insert in any subcontracts the clauses contained in subparagraphs 1 through 11 in this paragraph A and such other clauses as HUD or its designee may by appropriate instructions require, and a copy of the applicable prevailing wage decision, and also a clause requiring the subcontractors to include these clauses in any lower tier subcontracts. The prime contractor shall be responsible for the compliance by any subcontractor or lower tier subcontractor with all the contract clauses in this paragraph.

7. Contract termination; debarment. A breach of the contract clauses in 29 CFR 5.5 may be grounds for termination of the contract and for debarment as a contractor and a subcontractor as provided in 29 CFR 5.12.

8. Compliance with Davis-Bacon and Related Act Requirements. All rulings and interpretations of the Davis-Bacon and Related Acts contained in 29 CFR Parts 1, 3, and 5 are herein incorporated by reference in this contract

9. Disputes concerning labor standards. Disputes arising out of the labor standards provisions of this contract shall not be subject to the general disputes clause of this contract. Such disputes shall be resolved in accordance with the procedures of the Department of Labor set forth in 29 CFR Parts 5, 6, and 7. Disputes within the meaning of this clause include disputes between the contractor (or any of its subcontractors) and HUD or its designee, the U.S. Department of Labor, or the employees or their representatives.

10. (i) Certification of Eligibility. By entering into this contract the contractor certifies that neither it (nor he or she) nor any person or firm who has an interest in the contractor's firm is a person or firm ineligible to be awarded Government contracts by virtue of Section 3(a) of the Davis-Bacon Act or 29 CFR 5.12(a)(1) or to be

awarded HUD contracts or participate in HUD programs pursuant to 24 CFR Part 24.

(ii) No part of this contract shall be subcontracted to any person or firm ineligible for award of a Government contract by virtue of Section 3(a) of the Davis-Bacon Act or 29 CFR 5.12(a)(1) or to be awarded HUD contracts or participate in HUD programs pursuant to 24 CFR Part 24.

(iii) The penalty for making false statements is prescribed in the U.S. Criminal Code, 18 U.S.C. 1001. Additionally, U.S. Criminal Code, Section 1 01 0, Title 18, U.S.C., "Federal Housing Administration transactions", provides in part: "Whoever, for the purpose of . . . influencing in any way the action of such Administration..... makes, utters or publishes any statement knowing the same to be false..... shall be fined not more than \$5,000 or imprisoned not more than two years, or both."

11. Complaints, Proceedings, or Testimony by Employees. No laborer or mechanic to whom the wage, salary, or other labor standards provisions of this Contract are applicable shall be discharged or in any other manner discriminated against by the Contractor or any subcontractor because such employee has filed any complaint or instituted or caused to be instituted any proceeding or has testified or is about to testify in any proceeding under or relating to the labor standards applicable under this Contract to his employer.

B. Contract Work Hours and Safety Standards Act. The provisions of this paragraph B are applicable where the amount of the prime contract exceeds \$100,000. As used in this paragraph, the terms "laborers" and "mechanics" include watchmen and guards.

(1) Overtime requirements. No contractor or subcontractor contracting for any part of the contract work which may require or involve the employment of laborers or mechanics shall require or permit any such laborer or mechanic in any workweek in which the individual is employed on such work to work in excess of 40 hours in such workweek unless such laborer or mechanic receives compensation at a rate not less than one and one-half times the basic rate of pay for all hours worked in excess of 40 hours in such workweek.

(2) Violation; liability for unpaid wages; liquidated damages. In the event of any violation of the clause set forth in subparagraph (1) of this paragraph, the contractor and any subcontractor responsible therefor shall be liable for the unpaid wages. In addition, such contractor and subcontractor shall be liable to the United States (in the case of work done under contract for the District of Columbia or a territory, to such District or to such territory), for liquidated damages. Such liquidated damages shall be computed with respect to each individual laborer or mechanic, including watchmen and guards, employed in violation of the clause set forth in subparagraph (1) of this paragraph, in the sum of \$10 for each calendar day on which such individual was required or permitted to work in excess of the standard workweek of 40 hours without payment of the overtime wages required by the clause set forth in subparagraph (1) of this paragraph.

(3) Withholding for unpaid wages and liquidated damages. HUD or its designee shall upon its own action or upon written request of an authorized representative of the Department of Labor withhold or cause to be withheld, from any moneys payable on account of work performed by the contractor or subcontractor under any such contract or any other Federal contract with the same prime contract, or any other Federally-assisted contract subject to the Contract Work Hours and Safety Standards Act which is held by the same prime contractor such sums as may be determined to be necessary to satisfy any liabilities of such contractor or subcontractor for unpaid wages and liquidated damages as provided in the clause set forth in subparagraph (2) of this paragraph.

(4) Subcontracts. The contractor or subcontractor shall insert in any subcontracts the clauses set forth in subparagraph (1) through (4) of this paragraph and also a clause requiring the subcontractors to include these clauses in any lower tier subcontracts. The prime contractor shall be responsible for compliance by any subcontractor or lower tier subcontractor with the clauses set forth in subparagraphs (1) through (4) of this paragraph.

C. Health and Safety. The provisions of this paragraph C are applicable where the amount of the prime contract exceeds \$100,000.

(1) No laborer or mechanic shall be required to work in surroundings or under working conditions which are unsanitary, hazardous, or dangerous to his health and safety as determined under construction safety and health standards promulgated by the Secretary of Labor by regulation.

(2) The Contractor shall comply with all regulations issued by the Secretary of Labor pursuant to Title 29 Part 1926 and failure to comply may result in imposition of sanctions pursuant to the Contract Work Hours and Safety Standards Act, (Public Law 91-54, 83 Stat 96). 40 USC 3701 et seq.

(3) The contractor shall include the provisions of this paragraph in every subcontract so that such provisions will be binding on each subcontractor. The contractor shall take such action with respect to any subcontractor as the Secretary of Housing and Urban Development or the Secretary of Labor shall direct as a means of enforcing such provisions.

"General Decision Number: CO20210014 01/01/2021

Superseded General Decision Number: CO20200014

State: Colorado

Construction Type: Highway

Counties: Larimer, Mesa and Weld Counties in Colorado.

HIGHWAY CONSTRUCTION PROJECTS

Note: Under Executive Order (EO) 13658, an hourly minimum wage of \$10.95 for calendar year 2021 applies to all contracts subject to the Davis-Bacon Act for which the contract is awarded (and any solicitation was issued) on or after January 1, 2015. If this contract is covered by the EO, the contractor must pay all workers in any classification listed on this wage determination at least \$10.95 per hour (or the applicable wage rate listed on this wage determination, if it is higher) for all hours spent performing on the contract in calendar year 2021. If this contract is covered by the EO and a classification considered necessary for performance of work on the contract does not appear on this wage determination, the contractor must pay workers in that classification at least the wage rate determined through the conformance process set forth in 29 CFR 5.5(a)(1)(ii) (or the EO minimum wage rate, if it is higher than the conformed wage rate). The EO minimum wage rate will be adjusted annually. Please note that this EO applies to the above-mentioned types of contracts entered into by the federal government that are subject to the Davis-Bacon Act itself, but it does not apply to contracts subject only to the Davis-Bacon Related Acts, including those set forth at 29 CFR 5.1(a)(2)-(60). Additional information on contractor requirements and worker protections under the EO is available at www.dol.gov/whd/govcontracts.

Modification Number Publication Date
0 01/01/2021

* ENGI0009-012 05/01/2018

Rates Fringes

POWER EQUIPMENT OPERATOR:

(3)- Drill Rig Caisson
(smaller than Watson 2500
and similar).....\$ 28.25 10.70

(4)-Oiler		
Weld County.....	\$ 27.49	10.70
(5)-Drill Rig Caisson		
(Watson 2500 similar or		
larger).....	\$ 28.57	10.70

 SUCO2011-009 09/15/2011

	Rates	Fringes
--	-------	---------

CARPENTER

Excludes Form Work.....	\$ 20.72	5.34
Form Work Only		
Larimer, Mesa.....	\$ 18.79	3.67
Weld.....	\$ 16.54	3.90

CEMENT MASON/CONCRETE FINISHER

Larimer.....	\$ 16.05	3.00
Mesa.....	\$ 17.53	3.00
Weld.....	\$ 17.48	3.00

ELECTRICIAN

Excludes Traffic		
Signalization		
Weld.....	\$ 33.45	7.58
Traffic Signalization		
Weld.....	\$ 25.84	6.66

FENCE ERECTOR

Weld.....	\$ 17.46	3.47
-----------	----------	------

GUARDRAIL INSTALLER

Larmer, Weld.....	\$ 12.89	3.39
-------------------	----------	------

HIGHWAY/PARKING LOT

STRIPING:Painter

Larimer.....	\$ 14.79	3.98
Mesa.....	\$ 14.75	3.21
Weld.....	\$ 14.66	3.21

IRONWORKER, REINFORCING

(Excludes Guardrail
 Installation)

Larimer, Weld.....	\$ 16.69	5.45
--------------------	----------	------

IRONWORKER, STRUCTURAL

(Excludes Guardrail
 Installation)

Larimer, Weld.....	\$ 18.22	6.01
--------------------	----------	------

LABORER

Asphalt Raker

Larimer.....	\$ 18.66	4.66
Weld.....	\$ 16.72	4.25

Asphalt Shoveler.....	\$ 21.21	4.25
Asphalt Spreader.....	\$ 18.58	4.65
Common or General.....	\$ 16.29	4.25
Concrete Saw (Hand Held)....	\$ 16.29	6.14
Landscape and Irrigation....	\$ 12.26	3.16
Mason Tender-		
Cement/Concrete.....	\$ 16.29	4.25
Pipelayer		
Larimer.....	\$ 17.27	3.83
Mesa, Weld.....	\$ 16.23	3.36
Traffic Control (Flagger)....	\$ 9.55	3.05
Traffic Control (Sets		
Up/Moves Barrels, Cones,		
Install Signs, Arrow		
Boards and Place		
Stationary Flags)(Excludes		
Flaggers)		
Larimer, Weld.....	\$ 12.43	3.22

PAINTER (Spray Only).....\$ 16.99 2.87

POWER EQUIPMENT OPERATOR:

Asphalt Laydown		
Larimer.....	\$ 26.75	5.39
Mesa, Weld.....	\$ 23.93	7.72
Asphalt Paver.....	\$ 21.50	3.50
Asphalt Roller		
Larimer.....	\$ 23.57	3.50
Mesa.....	\$ 24.25	3.50
Weld.....	\$ 27.23	3.50
Asphalt Spreader		
Larimer.....	\$ 25.88	6.80
Mesa, Weld.....	\$ 23.66	7.36
Backhoe/Trackhoe		
Larimer.....	\$ 21.46	4.85
Mesa.....	\$ 19.81	6.34
Weld.....	\$ 20.98	6.33
Bobcat/Skid Loader		
Larimer.....	\$ 17.13	4.46
Mesa, Weld.....	\$ 15.37	4.28
Boom.....	\$ 22.67	8.72
Broom/Sweeper		
Larimer.....	\$ 23.55	6.20
Mesa.....	\$ 23.38	6.58
Weld.....	\$ 23.23	6.89
Bulldozer		
Larimer, Weld.....	\$ 22.05	6.23
Mesa.....	\$ 22.67	8.72
Crane.....	\$ 26.75	6.16
Drill		
Larimer, Weld.....	\$ 31.39	0.00
Mesa.....	\$ 35.06	0.00
Forklift.....	\$ 15.91	4.68
Grader/Blade		

Larimer.....	\$ 24.82	5.75
Mesa.....	\$ 23.42	9.22
Weld.....	\$ 24.53	6.15
Guardrail/Post Driver.....	\$ 16.07	4.41
Loader (Front End)		
Larimer.....	\$ 20.45	3.50
Mesa.....	\$ 22.44	9.22
Weld.....	\$ 23.92	6.67
Mechanic		
Larimer.....	\$ 27.68	4.57
Mesa.....	\$ 25.50	5.38
Weld.....	\$ 24.67	5.68
Oiler		
Larimer.....	\$ 24.16	8.35
Mesa.....	\$ 23.93	9.22
Roller/Compactor (Dirt and Grade Compaction)		
Mesa, Weld.....	\$ 21.33	6.99
Roller/Compactor (Dirt and Grade Compaction)		
Larimer.....	\$ 23.67	8.22
Rotomill		
Larimer.....	\$ 18.59	4.41
Weld.....	\$ 16.22	4.41
Scraper		
Larimer.....	\$ 21.33	3.50
Mesa.....	\$ 24.06	4.13
Weld.....	\$ 30.14	1.40
Screed		
Larimer.....	\$ 27.20	5.52
Mesa.....	\$ 27.24	5.04
Weld.....	\$ 27.95	3.50
Tractor.....	\$ 13.13	2.95

TRAFFIC SIGNALIZATION:

Groundsman

Larimer.....	\$ 11.44	2.84
Mesa.....	\$ 16.00	5.85
Weld.....	\$ 16.93	3.58

TRUCK DRIVER

Distributor

Larimer.....	\$ 19.28	4.89
Mesa.....	\$ 19.17	4.84
Weld.....	\$ 20.61	5.27

Dump Truck

Larimer.....	\$ 18.86	3.50
Mesa.....	\$ 15.27	4.28
Weld.....	\$ 15.27	5.27

Lowboy Truck

Larimer.....	\$ 18.96	5.30
Mesa, Weld.....	\$ 18.84	5.17
Mechanic.....	\$ 26.48	3.50

Multi-Purpose Specialty &

Hoisting Truck		
Larimer, Mesa.....\$ 16.65		5.46
Weld.....\$ 16.87		5.56
Pickup and Pilot Car.....\$ 13.93		3.68
Semi/Trailer Truck.....\$ 18.39		4.13
Truck Mounted Attenuator....\$ 12.43		3.22
Water Truck		
Larimer.....\$ 19.14		4.99
Mesa.....\$ 15.96		5.27
Weld.....\$ 19.28		5.04

WELDERS - Receive rate prescribed for craft performing operation to which welding is incidental.

=====

Note: Executive Order (EO) 13706, Establishing Paid Sick Leave for Federal Contractors applies to all contracts subject to the Davis-Bacon Act for which the contract is awarded (and any solicitation was issued) on or after January 1, 2017. If this contract is covered by the EO, the contractor must provide employees with 1 hour of paid sick leave for every 30 hours they work, up to 56 hours of paid sick leave each year. Employees must be permitted to use paid sick leave for their own illness, injury or other health-related needs, including preventive care; to assist a family member (or person who is like family to the employee) who is ill, injured, or has other health-related needs, including preventive care; or for reasons resulting from, or to assist a family member (or person who is like family to the employee) who is a victim of, domestic violence, sexual assault, or stalking. Additional information on contractor requirements and worker protections under the EO is available at www.dol.gov/whd/govcontracts.

Unlisted classifications needed for work not included within the scope of the classifications listed may be added after award only as provided in the labor standards contract clauses (29CFR 5.5 (a) (1) (ii)).

The body of each wage determination lists the classification and wage rates that have been found to be prevailing for the cited type(s) of construction in the area covered by the wage determination. The classifications are listed in alphabetical order of ""identifiers"" that indicate whether the particular rate is a union rate (current union negotiated rate for local), a survey rate (weighted average rate) or a union average rate (weighted union average rate).

Union Rate Identifiers

A four letter classification abbreviation identifier enclosed in dotted lines beginning with characters other than ""SU"" or ""UAVG"" denotes that the union classification and rate were prevailing for that classification in the survey. Example: PLUM0198-005 07/01/2014. PLUM is an abbreviation identifier of the union which prevailed in the survey for this classification, which in this example would be Plumbers. 0198 indicates the local union number or district council number where applicable, i.e., Plumbers Local 0198. The next number, 005 in the example, is an internal number used in processing the wage determination. 07/01/2014 is the effective date of the most current negotiated rate, which in this example is July 1, 2014.

Union prevailing wage rates are updated to reflect all rate changes in the collective bargaining agreement (CBA) governing this classification and rate.

Survey Rate Identifiers

Classifications listed under the ""SU"" identifier indicate that no one rate prevailed for this classification in the survey and the published rate is derived by computing a weighted average rate based on all the rates reported in the survey for that classification. As this weighted average rate includes all rates reported in the survey, it may include both union and non-union rates. Example: SULA2012-007 5/13/2014. SU indicates the rates are survey rates based on a weighted average calculation of rates and are not majority rates. LA indicates the State of Louisiana. 2012 is the year of survey on which these classifications and rates are based. The next number, 007 in the example, is an internal number used in producing the wage determination. 5/13/2014 indicates the survey completion date for the classifications and rates under that identifier.

Survey wage rates are not updated and remain in effect until a new survey is conducted.

Union Average Rate Identifiers

Classification(s) listed under the UAVG identifier indicate that no single majority rate prevailed for those classifications; however, 100% of the data reported for the classifications was union data. EXAMPLE: UAVG-OH-0010 08/29/2014. UAVG indicates that the rate is a weighted union average rate. OH indicates the state. The next number, 0010 in the example, is an internal number used in producing the wage determination. 08/29/2014 indicates the survey completion date for the classifications and rates under that identifier.

A UAVG rate will be updated once a year, usually in January of each year, to reflect a weighted average of the current negotiated/CBA rate of the union locals from which the rate is

based.

WAGE DETERMINATION APPEALS PROCESS

1.) Has there been an initial decision in the matter? This can be:

- * an existing published wage determination
- * a survey underlying a wage determination
- * a Wage and Hour Division letter setting forth a position on a wage determination matter
- * a conformance (additional classification and rate) ruling

On survey related matters, initial contact, including requests for summaries of surveys, should be with the Wage and Hour Regional Office for the area in which the survey was conducted because those Regional Offices have responsibility for the Davis-Bacon survey program. If the response from this initial contact is not satisfactory, then the process described in 2.) and 3.) should be followed.

With regard to any other matter not yet ripe for the formal process described here, initial contact should be with the Branch of Construction Wage Determinations. Write to:

Branch of Construction Wage Determinations
Wage and Hour Division
U.S. Department of Labor
200 Constitution Avenue, N.W.
Washington, DC 20210

2.) If the answer to the question in 1.) is yes, then an interested party (those affected by the action) can request review and reconsideration from the Wage and Hour Administrator (See 29 CFR Part 1.8 and 29 CFR Part 7). Write to:

Wage and Hour Administrator
U.S. Department of Labor
200 Constitution Avenue, N.W.
Washington, DC 20210

The request should be accompanied by a full statement of the interested party's position and by any information (wage payment data, project description, area practice material, etc.) that the requestor considers relevant to the issue.

3.) If the decision of the Administrator is not favorable, an interested party may appeal directly to the Administrative Review Board (formerly the Wage Appeals Board). Write to:

Administrative Review Board
U.S. Department of Labor
200 Constitution Avenue, N.W.
Washington, DC 20210

4.) All decisions by the Administrative Review Board are final.

=====

END OF GENERAL DECISION

"

Section 00120

BID PROPOSAL

PROJECT: 2021 Infrastructure Improvements Program

The Undersigned, having become familiar with the local conditions affecting the cost of the work, plans, drawings, and specifications attached herewith, and with advertisement for bids, the form of bid and proposal, form of bond, all of which are issued and attached and on file in the office of the Project Manager, hereby bid and propose to furnish all the labor, materials, necessary tools, and equipment and all utility and transportation service necessary to perform and complete in a workmanlike manner all of the work required in connection with the construction of the items listed on the bidding schedule in accordance with the plans and specifications as prepared by the City of Greeley, Colorado, for the sums set forth in the Bidding Schedule.

The total bid shall be the basis for establishing the amount of the Performance and Payment Bond for this project. The total bid is based on the quantities shown in the bid proposal form and the dimensions shown on the plans.

The undersigned has carefully checked the Bidding Schedule quantities against the plans and specifications before preparing this proposal and accepts the said quantities as substantially correct, both as to classification and the amounts, and as correctly listing the complete work to be done in accordance with the plans and specifications.

The undersigned, agrees to complete and file a Performance and Payment Bond and further agrees to complete the contract within ninety (90) Calendar Days from Notice to Proceed. Official notice to proceed will not be issued until adequate Performance and Payment Bonds and other required documents are on file with the City of Greeley.

NOTE: Bidders should not add any conditions or qualifying statements to this bid as otherwise the bid may be declared irregular as being non responsive to the Invitation for bids. The following numbered Addenda have been received and the bid, as submitted, reflects any changes resulting from those Addenda: _____

ATTEST

DATE

COMPANY NAME

BY

SIGNATURE

TITLE

Section 00130 - Bid Schedule

TOTAL

Item #	Description	Unit	Qty	Unit Price	Total Cost
1	Remove Curb & Gutter (0 to 2' Pan)	LF	3,401		\$ -
2	Remove Concrete Flatwork - Thickness Varies	SY	1,219		\$ -
3	Removal of Rollover C&G/Sidewalk	LF	0		\$ -
4	Remove Asphalt (Thickness Varies)	SY	0		\$ -
5	Sawcut Joint	LF	0		\$ -
6	Concrete Sawcut Demo	LF	312		\$ -
7	New C&G 0-2' Pan (i.e. Vertical Curb and Gutter: Sim to S-16)	LF	3,351		\$ -
8	New High Back Curb and Gutter (8" and above)	LF	50		\$ -
9	24 Hour High Early Mix - Up Charge	CY	0		\$ -
10	New Rollover C&G and SW	LF	0		\$ -
11	New 4" Concrete	SY	612		\$ -
12	New 6" Concrete	SY	472		\$ -
13	New 8" Concrete	SY	93		\$ -
14	New 5" Concrete w/ Fiber Reinforcement	SY	0		\$ -
15	Unclassified Excavation	CY	0		\$ -
16	Compacted Stabilization Subgrade Import (6" Base)	TON	0		\$ -
17	Major Re-landscaping (Sprinklers, etc.)	HR	0		\$ -
18	Reconstruct Inlet Top (up to 2' below grade)	EA	2		\$ -
19	Adjust Meter Pit	EA	0		\$ -
20	Landscape Curb 0-6"	LF	313		\$ -
21	Landscape Curb 7-18"	LF	0		\$ -
22	Landscape Curb 19-48"	LF	0		\$ -
23	ADA Detectable Warning plates/domes	SF	60		\$ -
24	Chase Drain (12" max opening)	SF	0		\$ -
25	Remove and Reset mailbox	EA	0		\$ -
26	Tree and Root Pruning	HR	8		\$ -
27	Saw Cut to Preserve Asphalt	LF	3,335		\$ -
28	Colored Concrete (4 LB Max.) (Add On)	CY	0		\$ -
29	Stamped Concrete (Add On)	SY	0		\$ -
30	Portable Sanitary Station	LS	0		\$ -
31	4" PVC Installed Under Sidewalk	LF	0		\$ -
					\$ -
32	Arrow Board	Day	0		\$ -
33	Certified Flagger (When Directed By City)	Hour	0		\$ -
					\$ -
34	Quality Control - Standard Proctor	EA	0		\$ -
35	Quality Control - Soils Compaction	EA	0		\$ -
36	Quality Control - Concrete Test & Break Results	EA	0		\$ -
				Total Bid: \$	0.00

Vendor Name: _____

Authorized Signature: _____

Print Name: _____

Phone Number: _____

Email Address: _____ Date: _____

COOPERATIVE PURCHASING STATEMENT

The City of Greeley encourages and participates in cooperative purchasing endeavors undertaken by or on behalf of other governmental jurisdictions. To the extent, other governmental jurisdictions are legally able to participate in cooperative purchasing endeavors; the City of Greeley supports such cooperative activities. Further, it is a specific requirement of this proposal or Request for Proposal that pricing offered herein to the City of Greeley may be offered by the vendor to any other governmental jurisdiction purchasing the same products. The vendor(s) must deal directly with any governmental agency concerning the placement of purchase orders, contractual disputes, invoicing, and payment. The City of Greeley shall not be liable for any costs or damages incurred by any other entity.

SECTION 00140

BID BOND

KNOW ALL MEN BY THESE PRESENT, that we, the undersigned _____ as Principal, and _____ as Surety, are hereby held and firmly bound unto the City of Greeley, Colorado, as Owner, in the penal sum of _____ for the Payment of which, well and truly to be made, we hereby jointly and severally bind ourselves, successors, and assigns.

THE CONDITION of this obligation is such that whereas the Principal has submitted to the City of Greeley, Colorado, the accompanying bid and hereby made a part hereof to enter into a Contract Agreement for the construction of City of Greeley Project,

2021 Infrastructure Improvements Program - FD21-07-151

WHEREAS, the Owner, as condition for receiving said bid, requires that the Principal to deposit with the Owner as Bid Guaranty equal to five percent (5%) of the amount of said bid.

NOW, THEREFORE,

(a) If said bid shall be rejected; or in the alternate,

(b) If said bid shall be accepted and the Principal shall execute and deliver a Contract Agreement (properly completed in accordance with said bid) and shall furnish a Performance and Payment Bond upon the forms prescribed by the Owner for the faithful performance of said Agreement; and shall in all other respects perform the agreement created by the acceptance of said bid;

then this obligation shall be void, otherwise the same shall remain in force and effect; it being expressly understood and agreed that the liability of the Surety for any and all claims hereunder shall, in no event, exceed the penal amount of this obligation as herein stated.

The Surety, for value received, hereby stipulates and agrees that the obligations of said Surety and its bond shall be in no way impaired or affected by any extension of the time within which the Owner may accept such bid; and said Surety does hereby waive notice of any such extension.

IN WITNESS WHEREOF, the Principal and the Surety have hereunto set their hands and seals this _____ day of _____, 20_____, and such of them as are corporations have caused their corporate seals to be hereto affixed and these presents to be signed by their proper officers, the day and year first set forth above.

PRINCIPAL

SURETY

Name: _____

Address: _____

By: _____

Title: _____ Attorney _____

In-Fact:
(Seal)

(Seal)

NOTE: Surety Companies executing bonds must be authorized to transact business in the State of Colorado and be accepted to the Owner.

SECTION 00160

NOTICE OF PRE-BID CONFERENCE

2021 INFRASTRUCTURE IMPROVEMENTS PROGRAM - FD21-07-151

A pre-bid conference will be held:

On July 22, 2021 at 1:00 p.m., via Zoom meeting. All bidders are highly encouraged to attend.

Join Zoom Meeting

<https://greeleygov.zoom.us/j/87832719142>

Meeting ID: 878 3271 9142

Passcode: 923001

Dial by your location

+1 312 626 6799 US (Chicago)

+1 346 248 7799 US (Houston)

+1 669 900 6833 US (San Jose)

Representatives of the City of Greeley will be present to answer questions.

Each bidder shall submit the following declaration of attendance, along with the other bid documents.

I have attended the pre-bid conference _____

I have not attended the pre-bid conference _____

Name of Contracting Organization

Authorized Signature

Date

SECTION 00210

NOTICE OF AWARD

DATE:

TO:

Re: **2021 Infrastructure Improvements Program – FD21-07-151**

Dear Contractor:

The City of Greeley, Colorado (hereinafter called "the Owner") has considered the bids submitted for referenced work in response to its Invitation for Bids. You are hereby notified that your bid has been accepted for items and prices stated in the Bid Schedule in the amount of \$_____. You are required to execute the Contract Agreement, provide the necessary insurance certificates, the Performance and Payment Bonds within ten (10) days from the date of this Notice. If you fail to execute said Contract Agreement and furnish the necessary insurance certificates and bonds within the time allotted from this date, the Owner will be entitled to consider your rights arising out of the Owner's acceptance of your bid as abandoned and to demand payment of bid guaranty as damages. The Owner will be entitled to such other rights as may be granted by law. You are required to return an acknowledged copy of this Notice of Award and enclosures to Purchasing.

CITY OF GREELEY, COLORADO

By: Paul Trombino

Title: Director of Public Works

ACKNOWLEDGMENT: Receipt of the foregoing Notice of Award accompanied with a Performance and Payment Bond form and a signed copy of the Contract Document is hereby acknowledged this _____ day of _____, 20_____.

Bidder: _____

By: _____

SECTION 00310

CONTRACT

THIS AGREEMENT made and entered into this ____ day of _____, 20__, by and between the City of Greeley, Colorado, and under the laws of the state of Colorado, party of the first part, termed in the Contract Documents as the "Owner" and _____ party of the second part, termed in the Contract Documents as "Contractor".

WITNESSETH: In consideration of monetary compensation to be paid by the Owner to the Contractor at the time and in the manner hereinafter provided, the said Contractor has agreed, and does hereby agree, to furnish all labor, tools, equipment and material and to pay for all such items and to construct in every detail, to wit:

PROJECT: 2021 Infrastructure Improvements Program – FD21-07-151

at the price bid on the Proposal Form of \$_____ all to the satisfaction and under the general supervision of the Project Manager for the City of Greeley, Colorado.

The Contract Documents consist of this Agreement, the Conditions of the Contract (General, Supplementary and other Conditions), the Drawings, the Specifications, all Addenda issued prior to and all Modifications issued after execution of this Agreement. These form the Contract, and all are as fully a part of the Contract as if attached to this Agreement or repeated herein.

The Project Manager named herein shall interpret and construe the Contract Documents, reconciling any apparent or alleged conflicts and inconsistencies therein; and all of the work and all details thereof shall be subject to the approval and determination of the Project Manager as to whether or not the work is in accordance with Contract Documents. Said City Project Manager shall be the final arbiter and shall determine any and all questions that may arise concerning the Contract Documents, the performance of the work, the workmanship, quality of materials and the acceptability of the completed project. The decision of the Project Manager on all questions shall be final, conclusive and binding.

AND FOR SAID CONSIDERATION IT IS FURTHER PARTICULARLY AGREED BETWEEN THE PARTIES TO THIS AGREEMENT.

1. That construction and installation of the above enumerated work for the Owner shall be completed and ready for use in accordance with the time of completion described in the Bid form of this Contract. That the above enumerated work shall begin within ten (10) days of the official "Notice to Proceed". (Contract shall become void if work is not started at specified time.)

2. That said work and materials for the project covered by the Contract Documents shall be completely installed and delivered to the Owner, within the time above stated, clear and free from any and all liens, claims, and demands of any kind.
3. The full compensation to be paid the Contractor by the Owner pursuant to the terms of this Contract shall be payable as provided in the Contract Documents.
4. This Contract consists of the following component parts, all of which are as fully a part of the Contract as herein set out verbatim, or if not attached, as if hereto attached:

- Section 00110: Invitation for Bid
- Section 00115: Federal Requirements
- Section 00120: Bid Proposal
- Section 00130: Bid Schedule
- Section 00140: Bid Bond
- Section 00160: Pre-bid meeting
- Section 00210: Notice of Award
- Section 00310: Contract
- Section 00320: Performance Bond
- Section 00330: Payment Bond
- Section 00340: Certificate of Insurance
- Section 00350: Lien Waiver Release
- Section 00360: Debarment/Suspension Certification Statement
- Section 00410: Notice to Proceed
- Section 00420: Project Manager Notification
- Section 00430: Certificate of Substantial Completion
- Section 00440: Final Completion
- Section 00510: General Conditions of the Contract
- Section 00520: Subcontractors List
- Section 00620: Special Provisions

Addenda Number _____ Inclusive

Any modifications, including change orders, duly delivered after execution of this Agreement.

IN WITNESS WHEREOF, the parties have caused this instrument to be executed as of the day and year first above written.

City of Greeley, Colorado

Contractor

Approved as to Substance

Authorized Signature

City Manager-Roy Otto

Printed Name

Reviewed as to Legal Form
OFFICE OF THE CITY ATTORNEY

Title

By: _____
City Attorney-Doug Marek

Certification of Contract
Funds Availability

Director of Finance – John Karner

SECTION 00320

PERFORMANCE BOND

Bond No. _____

KNOWN ALL MEN BY THESE PRESENTS: that

(Firm) _____

(Address) _____

(an Individual), (a Partnership), (a Corporation), hereinafter referred to as "the Principal", and

(Firm) _____

(Address) _____

hereinafter referred to as "the Surety", are held and firmly bound unto the CITY OF GREELEY, 1000 10th Street, Greeley, CO. 80631, a Municipal Corporation, hereinafter referred to as "the Owner" in the penal sum of _____ in lawful money of the United States, for the payment of which sum well and truly to be made, we bind ourselves, successors and assigns, jointly and severally, firmly by these present.

THE CONDITIONS OF THIS OBLIGATION are such that whereas the Principal entered into a certain Contract Agreement with the Owner, dated the _____ day of _____, 20_____, a copy of which is hereto attached and made a part hereof for the performance of City of Greeley Project,

2021 Infrastructure Improvements Program – FD21-07-151

NOW, THEREFORE, if the Principal shall well, truly and faithfully perform its duties, all the undertakings, covenants, terms, conditions and agreements of said Contract Agreement during the original term thereof, and any extensions thereof which may be granted by the Owner, with or without Notice to the Surety and during the life of the guaranty period, and if he shall satisfy all claims and demands incurred under such Contract Agreement, and shall fully indemnify and save harmless the Owner from all cost and damages which it may suffer by reason of failure to do so, and shall reimburse and repay the Owner all outlay and expense which the Owner may incur in making good any default, and then this obligation shall be void; otherwise to remain in full force and effect.

PROVIDED, FURTHER, that the said Surety, for value received, hereby stipulates and agrees that no change, extension of time, alteration or addition to the terms of the Contract Agreement or to the work to be performed thereunder or the specifications accompanying the same shall in any way affect its obligation on this bond; and it does hereby waive notice of any such change, extension of time, alteration or addition to the terms of the Contract Agreement or to the work or to the specifications.

IN WITNESS WHEREOF, this instrument is executed this _____ day of _____, 20____.

PROVIDED, FURTHER, that no final settlement between the Owner and Contractor shall abridge the right of any beneficiary hereunder, whose claims may be unsatisfied.

IN PRESENCE OF:

PRINCIPAL

_____ By: _____

(Corporate Seal)

(Address)

IN PRESENCE OF:

OTHER PARTNERS

_____ By: _____

_____ By: _____

By: _____

IN PRESENCE OF:

SURETY

_____ By: _____

(Attorney-in-Fact)

(SURETY SEAL)

(Address)

NOTE: Date of Bond must not be prior to date of Contract Agreement. If Contractor is Partnership, all partners should execute bond.

IMPORTANT: Surety Company must be authorized to transact business in the State of Colorado and be acceptable to the Owner.

SECTION 00330

PAYMENT BOND

Bond No. _____

KNOWN ALL MEN BY THESE PRESENT: that

(Firm) _____

(Address) _____

(an Individual), (a Partnership), (a Corporation), hereinafter referred to as "the Principal", and

(Firm) _____

(Address) _____

hereinafter referred to as "the Surety", are held and firmly bound unto the CITY OF GREELEY, 1000 10th Street, Greeley, Co. 80631, a Municipal Corporation, hereinafter referred to as "the Owner", in the penal sum of

_____ in lawful money of the United States, for the payment of which sum well and truly to be made, we bind ourselves, successors and assigns, jointly and severally, firmly by these presents.

THE CONDITIONS OF THIS OBLIGATION are such that whereas the Principal entered into a certain Contract Agreement with the Owner, dated the _____ day of _____, 20_____, a copy of which is hereto attached and made a part hereof for the performance of

2021 Infrastructure Improvements Program – FD21-07-151

NOW, THEREFORE, if the Principal shall make payment to all persons, firms, subcontractors and corporations furnishing materials for or performing labor in the prosecution of the work provided for in such Contract Agreement, and any equipment and tools, consumed, rented or used in connection with the construction of such work and all insurance premiums on said work, and for all labor, performed in such work whether by subcontractor or otherwise, then this obligation shall be void; otherwise to remain in full force and effect.

PROVIDED, FURTHER, that the said Surety, for value received, hereby stipulates and agrees that no change, extension of time, alteration or addition to the terms of the Contract Agreement or to the work to be performed thereunder or the specifications accompanying the same shall in any way affect its obligation on this bond; and it does hereby waive notice of any such change, extension of time, alteration or addition to the terms of the Contract Agreement or to the work or to the specifications.

IN WITNESS WHEREOF, this instrument is executed this _____ day of _____, 20____.

PROVIDED, FURTHER, that no final settlement between the Owner and Contractor shall abridge the right of any beneficiary hereunder, whose claim may be unsatisfied.

IN PRESENCE OF:

PRINCIPAL

_____ By: _____

_____ (Corporate Seal)

_____ (Address)

IN PRESENCE OF:

OTHER PARTNERS

_____ By: _____

_____ By: _____

_____ By: _____

IN PRESENCE OF:

SURETY

_____ By: _____

_____ (Attorney-in-Fact)

_____ (SURETY SEAL)

_____ (Address)

NOTE: Date of bond must not be prior to date of Contract Agreement. If Contractor is Partnership, all partners should execute Bond.

IMPORTANT: Surety Company must be authorized to transact business in the State of Colorado and be acceptable to the Owner.

CERTIFICATE OF LIABILITY INSURANCE

05/14/2013

THIS CERTIFICATE IS ISSUED AS A MATTER OF INFORMATION ONLY AND CONFERS NO RIGHTS UPON THE CERTIFICATE HOLDER. THIS CERTIFICATE DOES NOT AFFIRMATIVELY OR NEGATIVELY AMEND, EXTEND OR ALTER THE COVERAGE AFFORDED BY THE POLICIES BELOW.

IMPORTANT: If the certificate holder is an ADDITIONAL INSURED, the policy(ies) must be endorsed. If SUBROGATION IS WAIVED, subject to the terms and conditions of the policy, certain policies may require an endorsement. A statement on this certificate does not confer rights to the certificate holder in lieu of such endorsement(s).

PRODUCER: ABC Insurance Company, P. O. Box 1234, Anywhere, USA. CONTACT NAME, PHONE, FAX, E-MAIL, ADDRESS, PRODUCER CUSTOMER ID #, INSURER(S) AFFORDING COVERAGE, NAIC #, INSURED: Sample Certificate.

COVERAGES

CERTIFICATE NUMBER:

REVISION NUMBER:

THIS IS TO CERTIFY THAT THE POLICIES OF INSURANCE LISTED BELOW HAVE BEEN ISSUED TO THE INSURED NAMED ABOVE FOR THE POLICY PERIOD INDICATED. NOTWITHSTANDING ANY REQUIREMENT, TERM OR CONDITION OF ANY CONTRACT OR OTHER DOCUMENT WITH RESPECT TO WHICH THIS CERTIFICATE MAY BE ISSUED OR MAY PERTAIN, THE INSURANCE AFFORDED BY THE POLICIES DESCRIBED HEREIN IS SUBJECT TO ALL THE TERMS, EXCLUSIONS AND CONDITIONS OF SUCH POLICIES.

Table with columns: INSR LTR, TYPE OF INSURANCE, ADDL INSR, SUBR INSR, WVD, POLICY NUMBER, POLICY EFF (MM/DD/YYYY), POLICY EXP (MM/DD/YYYY), LIMITS. Rows include: GENERAL LIABILITY, AUTOMOBILE LIABILITY, UMBRELLA LIAB, WORKERS COMPENSATION AND EMPLOYERS' LIABILITY.

DESCRIPTION OF OPERATIONS / LOCATIONS / VEHICLES (Attach ACORD 101, Additional Remarks Schedule, if more space is required)
City of Greeley is named as Additional Insured on General Liability. Waiver of subrogation is included on Work Compensation. This insurance is primary and noncontributory to insurance policies held by the City.

CERTIFICATE HOLDER: City of Greeley, 1000 10th St, Greeley, CO 80631-3808. CANCELLATION: SHOULD ANY OF THE ABOVE DESCRIBED POLICIES BE CANCELLED BEFORE THE EXPIRATION DATE THEREOF, NOTICE WILL BE DELIVERED IN ACCORDANCE WITH THE POLICY PROVISIONS. AUTHORIZED REPRESENTATIVE.

SECTION 00350

LIEN WAIVER RELEASE

TO: City of Greeley, Colorado (hereinafter referred to as "the OWNER".)

FROM: (hereinafter referred to as "the CONTRACTOR")

PROJECT: **2021 Infrastructure Improvements Program – FD21-07-151**

1. The CONTRACTOR does hereby release all Mechanic's Liens Rights, Miller Act Claim (40 USCA 270), Stop Notice, Equitable Liens and Labor and Material Bond Rights resulting from labor and/or materials, subcontract work, equipment or other work, rents, services or supplies heretofore furnished in and for the construction, design, improvement, alteration, additions to of the above described project.
2. This release is given for and in consideration of the sum of \$ and other good and valuable consideration. If no dollar consideration is herein recited, it is acknowledged that other adequate consideration has been received by the CONTRACTOR for this release.
3. In further consideration of the payment made or to be made as above set forth, and to induce the OWNER to make said payment, the CONTRACTOR agrees to defend and hold harmless the OWNER, employees, agents and assigns from any claim or claims hereinafter made by the CONTRACTOR and/or its material suppliers, subcontractors or employees, servants, agents or assigns of such persons against the project. The CONTRACTOR agrees to indemnify or reimburse all persons so relying upon this release for any and all sums, including attorney's fees and costs, which may be incurred as the result of any such claims.
4. It is acknowledged that the designation of the above project constitutes an adequate description of the property and improvements for which the CONTRACTOR has received consideration for this release.
5. It is further warranted and represented that all such claims against the CONTRACTOR or the CONTRACTOR's subcontractors and/or material suppliers have been paid or that arrangements, satisfactory to the OWNER and CONTRACTOR, have been made for such payments.
6. It is acknowledged that this release is for the benefit of and may be relied upon by the OWNER, the CONTRACTOR, and construction lender and the principal and surety on any labor and material bond for the project.

7. In addition to the foregoing, this instrument shall constitute a *** (full, final and complete) ***(partial) release of all rights, claims and demands of the CONTRACTOR against the OWNER arising out of or pertaining to the above referenced project. If partial, all rights and claims on the project are released up to and including the _____ day of Month, 20__ .

Dated this _____ day of _____, 20____.

CONTRACTOR

By: _____

Title: _____

STATE OF _____)
)ss.
COUNTY OF _____)

The foregoing instrument was acknowledged before me this _____ day of _____,
20__ by _____.

My Commission expires:

Notary Public

***Strike when not applicable

SECTION 00360

Debarment/Suspension Certification Statement

The proposer certifies that neither it nor its principals are presently debarred, suspended, proposed for debarment, declared ineligible or voluntarily excluded from participation in this transaction by any Federal, State, County, Municipal or any other department or agency thereof. The proposer certifies that it will provide immediate written notice to the City if at any time the proposer learns that its certification was erroneous when submitted or has become erroneous by reason of changed circumstance.

The City will verify debarment/suspension information for all federally funded projects using the www.sam.gov site. The awarded vendor of federally funded projects must be pre-registered on the www.sam.gov site and show up as active with no exclusions at the time of the bid opening.

DUNS#: _____

Name of Organization: _____

Authorized Signature: _____

Title: _____

Date: _____

SECTION 00410

NOTICE TO PROCEED

Month , 20

TO: NAME

PROJECT: **2021 INFRASTRUCTURE IMPROVEMENTS PROGRAM – FD21-07-151**

To Whom It May Concern:

You are hereby notified to commence work on the above-referenced project in accordance with the Contract Agreement dated Month , 20 .

You are to complete this project by Month , 20

CITY OF GREELEY, COLORADO

By: _____

Title: _____

Signature

SECTION 00420

PROJECT MANAGER NOTIFICATION

_____, 20_____

TO:

PROJECT: **2021 Infrastructure Improvements Program – FD21-07-151**

The Owner hereby designates _____ as its Project Manager and authorizes this individual, under the authority of the Director of Public Works to make all necessary and proper decisions with reference to the project. Contract interpretations, change orders and other requests for clarification or instruction shall be directed to the Project Manager. The Director of Public Works shall be authorized to bind the Owner with respect to any decision made in accordance with the contract document.

CITY OF GREELEY, COLORADO

By: _____

Title: _____

SECTION 00430

CERTIFICATE OF SUBSTANTIAL COMPLETION

TO: CONTRACTOR

PROJECT: 2021 INFRASTRUCTURE IMPROVEMENTS PROGRAM – FD21-07-151

Project or designated portion shall include: Describe Scope.

The work performed under this contract has been reviewed and found to be substantially complete. The Date of Substantial Completion of the Project or portion thereof designated above is hereby established as Month , 20 .

The date of commencement of applicable warranties required by the Contract Documents is stipulated in Section 00440 - Certificate of Final Acceptance.

DEFINITION OF DATE OF SUBSTANTIAL COMPLETION

The Date of Substantial Completion of the Work or designated portion thereof is the date certified by the Project Manager when construction is sufficiently complete, in accordance with the Contract Documents, so the Owner can occupy or utilize the Work or designated portion thereof for the use for which it is intended, as expressed in the Contract Documents.

A list of items to be completed or corrected, prepared by the Contractor and verified and amended by the Project Manager is attached hereto. The failure to include any items on such list does not alter the responsibility of the Contractor to complete all Work in accordance with the Contract Documents. The date of commencement of warranties for items on the attached list is as stipulated in Section 00440 – Certificate of Final Acceptance.

The Owner shall operate and maintain the Work or portion of the Work described above from the Date of Substantial Completion and be responsible for all costs associated with the completed work excluding cost related to warrantee work.

The Contractor will complete or correct the Work on the list of items attached hereto within
days from the above Date of Substantial Completion.

Contractor

Owner

(Note--Owner's and Contractor's legal and insurance counsel should review and determine insurance requirements and coverage; Contractor shall secure consent of surety company, if any.)

SECTION 00440

CERTIFICATE OF FINAL ACCEPTANCE

TO: **CONTRACTOR**

PROJECT NAME: **2021 INFRASTRUCTURE IMPROVEMENTS PROGRAM – FD21-07-151**

The work performed under this contract has been reviewed and found to meet the definition of final acceptance. This Certificate of Final Acceptance applies to the whole of the work.

The Date of Final Acceptance of the Project designated above is hereby established as: Month _____, 20____ at 2:00 pm. This date is also the date of commencement of applicable warranties associated with the Project described above and as required by the Contract Documents.

DEFINITION OF DATE OF FINAL ACCEPTANCE

The Date of Final Acceptance of the Work is the date certified by the City of Greeley's Project Manager when the work is 100% complete, in accordance with the Contract Documents, as amended by change order(s), or as amended below:

Amendment to the Certificate of Final Completion (if any): Describe Amendments.

The Contractor and/or the City Of Greeley shall define any claims or requests for additional compensation above (or as attachments to this document).

Final Acceptance shall not be achieved until the Contractor provides the City Of Greeley with all contract specified Contractor and Sub-contractor close out documents including final lien waivers, releases, insurances, manuals, training, test results, warranties, and other documents required by the Contract Documents, as amended.

Upon issuance of the Certificate of Final Acceptance the Contractor may submit an application for payment requesting final payment for the entire Work. Liquidated damages (if any) will be assessed at this time.

Contractor's acceptance of the final payment shall constitute a waiver by the Contractor of all claims arising out of or relating to the Work; except as noted under 'Amendment to the Certificate of Final Acceptance' above.

Agreed:

_____, 20____ _____, 20____
Contractor's Representative DATE Project Manager (COG) DATE

SECTION 00510

CITY OF GREELEY GENERAL CONDITIONS OF THE CONTRACT FOR CONSTRUCTION (REVISED MAY 2020)

ARTICLE 1 DEFINITIONS

- 1.1 **Bidder:** An architect, engineer, individual, firm, partnership, corporation or combination thereof, submitting a Bid for the Work.
- 1.2 **Change Notice:** A document issued to the Contractor specifying a proposed change to the Contract Documents. Unless otherwise expressly stated on the face of the Change Notice, a Change Notice is a proposal which may result in a Change Order.
- 1.3 **Change Order:** A document issued to the Contractor modifying the Contract.
- 1.4 **Construction Contract:** The Contract Documents, including the Contract for construction (hereinafter “the contract”) executed by the Contractor and the Owner covering the performance of the Work including the furnishing of labor, superintendence, materials, tools and equipment as indicated in the Contract Documents.
- 1.5 **Contract Documents:** Documents applicable to and specific to the construction of an individual Project, including the Contract and all other documents executed by the Contractor and Owner covering the performance of the work including but not limited to Specifications, Insurance Requirements, Contract Drawings, Conditions of the Contract (General and Supplementary), Owner Contractor Agreement, all Addenda, all change orders issued after execution of the Contract, Performance and Payment Bonds, and any other special provisions.
- 1.6 **Contract Drawings(Project Drawings):** Contract drawings, The plans, to include but not limited to plans, profiles, typical cross sections, general cross-sections, elevations, schedules, schematics, notes and details which show locations, character, dimensions, and details of the Work.
- 1.7 **Contractor:** The individual, firm, partnership, or corporation, or combination thereof, private, municipal, or public, including joint ventures, which, as an independent contractor, has entered into a contract with the Owner, who is referred to throughout the Contract Documents by singular number and masculine gender.
- 1.8 **Days:** Unless otherwise designated, days mean calendar days.

- 1.9 **Extra Work:** Work not provided for in the Contract as awarded but found to be essential to the satisfactory completion of the Contract, within its intended scope. Reimbursement for extra work is governed by Article 28, CHANGES, or Article 31, CONTRACTOR PROPOSALS.
- 1.10 **Field Order:** A written order issued to a contractor by the Owner, or Project Manager, effecting a minor change or clarification with instructions to perform work not included in the contract. The work will eventually become a Change Order. A field Order is an expedient process used in an emergency or need situation that in many cases does not involve an adjustment to the contract sum or an extension of the contract sum or an extension of the contract time.
- 1.11 **Final Acceptance:** The formal written acceptance by the Owner of the completed Work.
- 1.12 **Force Account:** A method of payment, other than lump sum or unit price, for Work ordered by Change Order or by written notice from the Owner. Reimbursement for force account work is governed by Article 36, FORCE ACCOUNT WORK.
- 1.13 **Furnishing:** Manufacturing, fabricating and delivering to the site of the Work materials, plant, power, tools, patterns, supplies, appliances, vehicles and conveyances necessary or required for the completion of the Work.
- 1.14 **General Conditions (GC):** A section of the Contract Documents which specifies, in general, the contractual conditions.
- 1.15 **General Terms:** Directed, required, permitted, ordered, designated, selected, prescribed or words of like import shall be understood to mean the direction, requirement, permission, order, designation, selection or prescription of the Project Manager. Approved, satisfactory, equal, necessary or words of like import shall be understood to mean approved by, acceptable to, satisfactory to, equal, necessary in the opinion of the Project Manager.
- 1.16 **Indicated:** A term meaning as shown on the Contract Drawings, or as specified and detailed in the Contract Documents.
- 1.17 **Installation, Install, or Installing:** Completely assembling, erecting and connecting material, parts, components, appliances, supplies and related equipment specified or required for the completion of the Work.
- 1.18 **Limit of Work:** Boundary within which the Work, excepting utility and drainage work in Public Right Of Way and Easements, is to be performed.
- 1.19 **Notice to Proceed:** Written notice from the Owner to the Contractor to proceed with the Work.
- 1.20 **Notice of Termination:** Written notice from the Owner to the Contractor to stop work under the Contract on the date and to the extent specified in the Notice of Termination.

- 1.21 **Owner:** The City of Greeley.
- 1.22 **Permanent Drainage Easement:** Area required to construct and maintain permanent drainage facilities for retention, release, and passage of surface water.
- 1.23 **Permanent Utility Easement:** Area required to construct and maintain utility facilities.
- 1.24 **Project:** That specific portion of the Work indicated in the Contract Documents.
- 1.25 **Project Manager:** The Owner's designated representative. The Project Manager has the authority to delegate portions of his responsibilities to others.
- 1.26 **Provide:** In reference to work to be performed by the Contractor, provide means furnish and install completely in place.
- 1.27 **Punch List:** Work determined to be incomplete or unacceptable at time of inspection for substantial completion.
- 1.28 **Samples:** Physical examples which illustrate materials, equipment, fixtures and workmanship which establish standards by which the Work will be judged.
- 1.29 **Schedule:** Acceptable schedules are BAR or GANTT Chart or CPM schedule.
- 1.30 **Shop Drawings:** Documents furnished by the Contractor to illustrate specific portions of the Work. Shop Drawings include drawings, diagrams, illustrations, schedules, charts, brochures, tables and other data describing fabrication and installation of specific portions of the Work.
- 1.31 **Specifications:** A document applicable to construction contracts containing the Technical Provisions.
- 1.32 **Subcontractor:** Any person, firm or corporation, other than the employees of the Contractor, who contracts with the Contractor to furnish labor, material or labor and materials, under this Contract.
- 1.33 **Special Provisions:** Provisions especially applicable to this Contract which invoke, modify and supplement the General Conditions which are included in the Contract Documents.
- 1.34 **Substantial Completion:** The state in the progress of Work when the Work, or a designated portion thereof, is sufficiently complete in accordance with the Contract Documents, so that Owner may access, occupy, use, and enjoy the Project, or designated portion thereof, for its intended purpose. Substantial Completion shall not occur until a temporary or permanent Certificate of Occupancy is issued and only minor punch list items remain for such Work.

1.35 **Technical Provisions:** Those provisions which specify the materials and execution of construction for work entering into the project.

1.36 **Work:** The construction, labor, materials, equipment, and contractual requirements as indicated in the Contract Documents, including alterations, amendments, or extensions thereto made by authorized changes.

1.37 **Work Site:** The area enclosed by the Limit of Work indicated in the Project Drawings and boundaries of local streets and public easements in which the Contractor is to perform work under the Contract. It shall also include areas obtained by the Contractor for use in connection with the Contract, when contiguous to the Limit of Work.

ARTICLE 2 INTERPRETATION

2.1 The documents comprising the Contract Documents are complementary and indicate the construction and completion of the Work. Anything mentioned in the Contract Specifications and not shown on the Contract Drawings, or shown on the Contract Drawings and not mentioned in the Contract Specifications, shall be of like effect as if shown or mentioned in both.

2.2 Where "as indicated", "as detailed", or words of similar import are used, it shall be understood that the reference is made to the specifications or drawings accompanying this Contract unless stated otherwise.

2.3 References to Articles or Sections include sub articles or subsections under the Article Reference (for example, a reference to Article 2 is also a reference to 2.1 through 2.9, and references to paragraphs similarly include references to subparagraphs).

2.4 **Referenced Standards:** Material and workmanship specified by the number, symbol, or title of a referenced standard shall comply with the latest edition or revision thereof and amendments and supplements thereto in effect on the date of the Invitation to Bid except where a particular issue is indicated.

2.5 **Precedence of Contract Documents:** Except as provided by Paragraph 2.1 of this Article, the Construction Contract governs over other Contract Documents, except that a Change Order governs over the Contract and previously issued Change Orders. The Contract Conditions govern over the General Conditions.

2.6 **Explanations:** Should it appear that the Work to be done or any of the matters relative thereto are not sufficiently detailed or explained in the Contract Documents, the Contractor shall apply to the Owner for such explanation provided as part of the Contract. Disputes over questions of fact which are not settled by agreement shall be decided by Owner. Such decision thereon will be final, subject to remedies under Article 35, DISPUTES.

2.7 Should there be any conflict, detailed instructions govern over general instructions, detail drawings have precedence over small scale drawings, and dimensions have precedence over scale.

2.8 Omissions and Misdemeanors: The Contractor shall carefully study and compare all drawings, specifications, Contract Documents and other instructions; shall verify all dimensions on the Contract Drawings before laying out the Work; shall notify the Project Manager of all errors, inconsistencies or omissions which he may discover; and obtain specific instructions in writing before proceeding with the Work. The Contractor shall not take advantage of apparent errors or omissions which may be found in the Contract Documents, but the Project Manager shall be entitled to make such corrections therein and interpretations thereof as he may deem necessary for the fulfillment of their intent. The Contractor shall be responsible for all errors in construction which could have been avoided by such examination and notification, subject to remedies under Article 35, Disputes.

ARTICLE 3 ENTITY OF CONTRACTOR

3.1 If the Contractor hereunder is comprised of more than one legal entity, each such entity shall be jointly and severally liable hereunder.

ARTICLE 4 LIABILITY AND INDEMNIFICATION

4.1 It is agreed that the Contractor assumes responsibility and liability for damages, loss or injury of any kind or nature whatever to persons or property caused by or resulting from or in connection with any act, action, neglect, omission, or failure to act when under a duty to act on the part of the Contractor or any of his officers, agents, employees, or subcontractors in his or their performance of the Work. The Contractor shall indemnify and hold harmless the Government, the State, the Owner and the Project Manager and their members, officers, agents, or employees from claims, losses, damages, charges, costs, or expenses, including attorney's fees, whether direct or indirect, to which they or any of them may be put or subjected to by reason of any such loss or injury.

ARTICLE 5 PROTECTION OF EXISTING VEGETATION, STRUCTURES, UTILITIES, AND IMPROVEMENTS AND LAND SURVEY MONUMENTS

5.1 A Contractor shall preserve and protect existing vegetation such as trees, shrubs, and grass on or adjacent to the work site which are not indicated to be removed and which do not unreasonably interfere with the construction work and he shall replace in kind any vegetation, shrubs and grass damaged by him at his own expense.

5.2 The Contractor shall protect from damage all utilities, structures, or improvements on or near the site of the Work and shall repair or restore any damage to such utilities, structures, or improvements resulting from failure to comply with the requirements of the Contract or the failure to exercise reasonable care in the performance of the Work. If the Contractor fails or refuses to repair

any such damage promptly, the Owner may have the necessary work performed and charge the cost thereof to the Contractor.

5.3 All land survey monuments shall be protected from any damage by any work and/or shall be replaced by a licensed land surveyor licensed in the state of Colorado at the contractor's expense before final acceptance is issued.

ARTICLE 6 CONTRACTUAL RELATIONSHIPS

6.1 No contractual relationship will be recognized under the Contract other than the contractual relationship between the Owner and the Contractor.

ARTICLE 7 ASSIGNMENT

7.1 The performance of the Work under the Contract shall not be assigned except upon written consent of the Owner. Consent will not be given to any proposed assignment which would relieve the Contractor or his surety of their responsibilities under the Contract. The Contractor shall not assign any monies due or to become due to him under the Contract without the previous written consent of the Owner.

ARTICLE 8 SUBCONTRACTORS

8.1 Unless otherwise required by the Contract Documents or the Bidding Documents, the Contractor, as soon as practicable after the award of the Contract, not to exceed 3 days, shall furnish to the Owner and the Project Manager, in writing the names of the subcontractors, persons or entities (including those who are to furnish materials or equipment fabricated to a special design) proposed for each of the principal portions of the Work. The Project Manager will promptly reply to the Contractor in writing whether or not the Owner or the Project Manager, after due investigation, has reasonable objection to any such proposed person or entity. Failure of the Owner or Project Manager to reply promptly shall constitute notice of no reasonable objections.

ARTICLE 9 CONDITIONS AFFECTING THE WORK

9.1 The Contractor shall be responsible for taking steps reasonably necessary to ascertain the nature and location of the Work, and the general and local conditions which can affect the Work or the cost thereof. Failure by the Contractor to do so will not relieve him from responsibility for successfully performing work without additional expense to the Owner. The Owner will not be responsible for any understanding or representations concerning conditions, unless such understanding or representations are expressly stated in the Contract.

**ARTICLE 10
GRATUITIES AND CONFLICTS OF INTEREST**

10.1 The Owner may, by written notice to the Contractor terminate the right of the Contractor to proceed under this Contract if it is found that gratuities (in the form of entertainment, gifts, or otherwise) were offered or given by the Contractor, or any agent or representative of the Contractor or any director, officer or employee of the Owner or its Project Manager with a view toward securing a contract or securing favorable treatment with respect to the awarding or amending, or the making of any determinations with respect to the performance of such contract. The Owner's determination shall be final subject only to judicial review.

10.2 In the event this Contract is terminated for any reason, the Owner shall be entitled to pursue the same remedies against the Contractor as it could pursue in the event of a breach of the Contract by the Contractor.

10.3 No member, officer or employee of the Owner or of a local public body during his tenure or for one year thereafter shall have any interest, direct or indirect, in this Contract or the proceeds thereof. "Local public body" means the State, any political subdivision of the State, or any agency of the State or any political subdivision thereof.

10.4 The rights and remedies of the Owner provided in this article are not exclusive and are in addition to any other rights and remedies provided by law or under the Contract.

**ARTICLE 11
WARRANTY OF WORK**

11.1 Except where longer periods of warranty are indicated for certain items, the Contractor warrants work under the Contract to be free from faulty materials and workmanship for a period of not less than two years from date of Final Acceptance, which two year period shall be covered by the Performance Bond and Payment Bond as specified in this Contract. The Contractor shall immediately remedy, repair, or replace, without cost to the Owner and to the entire satisfaction of the Owner, defects, damages, or imperfections due to faulty materials or workmanship appearing in said work within said period of not less than two years. Remedied work shall carry the same warranty as the original work starting with the date of acceptance of the replacement or repair. Payment to the Contractor will not relieve him of any obligation under this Contract.

11.2 The Contractor, at no additional expense to the Owner, shall also remedy damage to equipment, the site, or the building or the contents thereof which is the result of any failure or defect in the Work, and restore any work damaged in fulfilling the requirements of the Contract. Should the Contractor fail to remedy any such failure or defect within a reasonable time but no longer than ten (10) days after receipt of notice thereof, the Owner will have the right to replace, repair, or otherwise remedy such failure or defect at the Contractor's expense.

11.3 Subcontractors', manufacturers', and suppliers' warranties and guarantees, expressed or implied, respecting any part of the Work and any material used therein shall be deemed obtained and

shall be enforced by the Contractor for the Benefit of the Owner without the necessity of separate transfer or assignment thereof.

11.4 The rights and remedies of the Owner provided in this Article are in addition to and do not limit any rights and remedies afforded by the Contract or by law.

ARTICLE 12 MATERIAL

12.1 Unless otherwise indicated in this Contract, equipment, material and products incorporated in the Work covered by this Contract shall be new and of the grade specified in the Contract for the purpose intended. Unless otherwise specifically indicated, reference to equipment, material, product or patented process by trade names, make, or catalog number, shall be regarded as establishing a standard of quality and shall not be construed as limiting competition, and the Contractor may, at his option, use any equipment, material, article, or process which is equivalent to that named, subject to the requirements of Paragraph 12.2 of this Article.

12.2 Within the scope of his authority, the Project Manager shall be the sole judge of the quality and suitability of proposed alternative equipment, material, article or process. The burden of proving the quality and suitability of the alternative shall be upon the Contractor. Information required by the Project Manager in judging an alternative shall be submitted for approval by the Contractor at the Contractor's expense prior to installation.

12.3 Where use of an alternative material involves redesign of or changes to other parts of the Work, the cost and the time required to affect such redesign or change will be considered in evaluating the suitability of the alternative material. Redesign and changes in other parts of the Work shall be at the Contractor's expense.

12.4 No action relating to the approval of alternative materials will be taken by the Project Manager until the request for substitution is made in writing by the Contractor accompanied by complete data as to the quality and suitability of the materials proposed. Such request shall be made in ample time to permit approval without delaying the Work.

12.5 Disposal of material outside the Work Site: The Contractor shall make his own arrangements for legally disposing of waste and excess materials outside the Work Site and he shall pay costs therefore.

12.6 Property rights in materials: The Contractor shall have no property right in materials after they have been attached or affixed to the Work or the soil, or after payment has been made by the Owner to the Contractor for materials delivered to the site of the Work, or stored subject to or under the control of the Owner as provided in Article 24, PROGRESS PAYMENTS.

ARTICLE 13 WORKMANSHIP AND UNAUTHORIZED WORK

13.1 Work under this Contract shall be performed in a skillful and workmanlike manner. The Project Manager may, in writing, require the Contractor to remove from the work any employee the Project Manager determines incompetent, careless or otherwise objectionable.

13.2 Unauthorized work: Work performed beyond the lines and grades shown on the Contract Drawings, approved Working and Shop Drawings and Extra work done without written authorization, will be considered as unauthorized work, and the Contractor will receive no compensation therefore. If required by the Owner, unauthorized work shall be remedied, removed, or replaced by the Contractor at the Contractor's expense. Upon failure of the Contractor to remedy, remove or replace unauthorized work, the Owner may take courses of action set out in Paragraph 15.3 of Article 15, INSPECTION.

ARTICLE 14 SUPERINTENDENCE BY CONTRACTOR

14.1 The Contractor shall give his personal superintendence to the Work or have a competent foreman or superintendent, hereinafter designated his authorized representative, satisfactory to the Owner, on the Work Site at all times during progress, with authority to act for him. There shall be provided at all times, a reasonable method of communication directly to the Contractor if the Owner experiences any problems or difficulties with the Superintendent.

ARTICLE 15 INSPECTION/TESTING

15.1 Work (which term includes but is not restricted to materials, workmanship and manufacture and fabrication of components) will be subject to inspection and test by the Project Manager at all reasonable times and at all places prior to acceptance. Such inspection and test is for the sole benefit of the Owner and shall not relieve the Contractor of the responsibility of providing quality control measures to assure that the Work strictly complies with the Contract Documents. No inspection or test by the Project Manager shall be construed as constituting or implying acceptance. Inspection or test shall not relieve the Contractor of responsibility for damage to or loss of the material prior to acceptance, nor in any way affect the continuing rights of the Owner after acceptance of the completed Work.

15.2 The Contractor shall, at his own expense, replace any material or correct any workmanship found not to conform to the contract requirements, unless the Owner consents in writing to accept such material or workmanship with an appropriate adjustment in contract price. The Contractor shall promptly segregate and remove rejected material from the premises at his own expense.

15.3 If the Contractor does not promptly replace rejected material or correct the rejected workmanship, the Owner (1) may, by separate contract or otherwise, replace such material or correct such workmanship and charge the cost thereof to the Contractor, or (2) may terminate the Contractor's right to proceed in accordance with Article 38, TERMINATION FOR DEFAULT-DAMAGES FOR DELAY--TIME EXTENSIONS.

15.4 The Contractor shall give the Project Manager ample notification of inspections and tests, and the Project Manager will perform, except as otherwise specifically provided, said inspections and tests in such manner as not to unnecessarily delay the work. The Owner will have the right to charge to the Contractor any additional cost of inspection or test or when reinspection or retest is necessitated by prior rejection.

15.5 Should it be considered necessary, before acceptance of the entire work, to make an examination of work already completed by removing or tearing out same, the Contractor shall on request promptly furnish all necessary facilities, labor and material therefore. If such work is found to be defective or nonconforming in any material respect, due to the fault of the Contractor or his subcontractors, he shall defray the expenses of such examination and of satisfactory reconstruction. If, however, such work is found to meet the requirements of the Contract, an equitable adjustment will be made in the contract price to compensate the Contractor for the additional services involved in such examination and reconstruction. If completion for the work has been delayed thereby, he will, in addition, be granted an equitable extension of time.

15.6 The Project Manager shall have access to the work during its construction. Work done and materials provided will be subject to the Project Manager's on-site and off-site inspection and approval. When work is to be performed during hours other than during his normal schedule, the Contractor shall so advise the Project Manager not less than 24 hours in advance. The Contractor shall provide access to the work for authorized representatives of the Owner.

15.7 The Project Manager's inspection and approval of work or materials shall not relieve the Contractor of any of his obligations to fulfill the requirements of the Contract Documents. Work and materials not meeting the requirements of the Contract shall not be incorporated in the Work. Unsuitable or substandard work or materials may be rejected by the Project Manager, notwithstanding that such work or materials may have been previously inspected by the Project Manager, or that payment therefore has been included in a progress payment.

ARTICLE 16 PERMITS AND COMPLIANCE WITH LAWS

16.1 The Contractor shall without additional expense to the Owner be responsible for obtaining necessary licenses and permits and for complying with applicable Federal, State, County and Municipal laws, codes and regulations in connection with the commencement of the work. The Contractor is required to supply the Project Manager with complete and final copies of license and permits including final inspection documentation. The Contractor shall be required to obtain permits at his own expense. The Contractor shall protect, indemnify and hold harmless the Owner and the Project Manager and their members, officers, agents and employees against claims and liabilities arising from or based on the violation of requirements of law or permits whether by the Contractor, his employees, agents or subcontractors.

**ARTICLE 17
RIGHTS IN LAND IMPROVEMENT**

17.1 The Contractor shall make no arrangements with any person to permit occupancy or use of any land, structure or building within the work site for any purpose whatsoever, either with or without compensation, in conflict with any agreement between the Owner and any owner, former owner or tenant of such land, structure or building. The Contractor shall not occupy Owner property outside the work site without obtaining prior written approval from the Owner.

**ARTICLE 18
DAMAGE TO THE WORK AND RESPONSIBILITY FOR MATERIALS**

18.1 The Contractor shall be responsible for materials delivered and work performed until completion and final acceptance of the entire construction thereof.

18.2 The Contractor shall bear the risk of injury, loss or damage to any and all parts of the work for whatever cause, whether arising from the execution or from the non-execution of work. The Contractor shall rebuild, repair or restore work and materials which have been damaged or destroyed from any cause before completion and acceptance of the work and shall bear the expense thereof. The Contractor shall provide security and drainage and erect temporary structures as necessary to protect the work and materials from damage.

18.3 The Contractor shall be responsible for materials not delivered to the site for which any progress payment has been made to the same extent as if the materials were so delivered.

**ARTICLE 19
EMERGENCIES**

19.1 In an emergency affecting the safety of life, the work, or adjacent property, the Contractor shall notify the Project Manager as early as possible that an emergency exists. In the meantime, without special instruction from the Project Manager as to the manner of dealing with the emergency, the Contractor shall act at his own discretion to prevent such threatened loss or injury. As emergency work proceeds, the Project Manager may issue instruction, which the Contractor shall follow. The amount of compensation to which Contractor is entitled on account of emergency work will be determined in accordance with Article 28, CHANGES.

**ARTICLE 20
NOTICE TO PROCEED**

20.1 The Owner will issue a Notice to Proceed to the Contractor within 15 days after the Contractor has executed the Contract and has delivered the specified bonds and Certificates of Insurance as required by the Owner. Except as specifically authorized in writing by the Owner, the Contractor is not authorized to perform work under the Contract until the effective date of the Notice to Proceed. Within 10 days after the effective date of such Notice to Proceed, the Contractor shall

commence work and shall diligently prosecute the Work to completion within the time limits specified. These time periods may be modified by mutual written agreement of both the Owner and Contractor.

ARTICLE 21
PROGRESS SCHEDULE AND REQUIREMENTS FOR MAINTAINING PROGRESS

21.1 The Contractor shall, at the pre-construction meeting, prepare and submit to the Project Manager for approval a practicable schedule, showing the order in which the Contractor proposes to carry on the work, the date on which he will start the several salient features (including procurement of materials, plant and equipment) and the contemplated dates for completing the same. The schedule shall be in the form of a progress chart of suitable scale to indicate appropriately the percentage of work scheduled for completion at any time. The Contractor shall update the chart with the actual progress monthly or at such intervals as directed by the Project Manager, and shall immediately deliver three copies thereof. If the Contractor fails to submit a progress schedule within the time herein prescribed, the Project Manager may withhold approval of progress payment estimates until such time as the Contractor submits the required progress schedule.

21.2 The Contractor shall prosecute the work in accordance with the latest approved Progress Schedule. In the event, that the progress of items along the critical path is delayed, the Contractor shall revise his planning to include additional forces, equipment, shifts or hours as necessary to meet the time or times of completion specified in this Contract. Additional costs resulting therefrom will be borne by the Contractor. The Contractor shall make such changes when his progress at any check period does not meet at least one of the following two tests:

21.2.1 The percentage of dollar value of completed work with respect to the total amount of the Contract is within ten percentage points of the percentage of the Contract time elapsed, or;

21.2.2 The percentage of dollar value of completed work is within ten percentage points of the dollar value which should have been performed according to the Contractors own network analysis previously approved by the Project Manager.

21.3 Failure of the Contractor to comply with the requirements under this provision will be grounds for determination that the Contractor is not prosecuting the work with such diligence as will ensure completion within the time of completion specified in this Contract. Upon such determination, the Owner may terminate the Contractor's right to proceed with the work, or any separate part thereof, in accordance with Article 38, TERMINATION FOR DEFAULT--DAMAGES FOR DELAY-TIME EXTENSIONS of these General Conditions.

ARTICLE 22
SUSPENSION OF WORK

22.1 The Owner reserves the right to suspend, delay or interrupt execution of the whole or any part of the work for such period of time as he may determine to be appropriate for his convenience.

22.2 If the performance of all or any part of the work is, for an unreasonable period of time, suspended, delayed, or interrupted by an act of the Owner in the administration of this Contract or by his failure to act within the time specified in this Contract (or if no time is specified, within a reasonable time), an adjustment shall be made for any increase in the cost of performance of this Contract (excluding profit) necessarily caused by such unreasonable suspension, delay, or interruption and the contract modified in writing accordingly. However, no adjustment shall be made under this clause for any suspension, delay, or interruption to the extent (1) that performance would have been so suspended, delayed or interrupted by any other cause, including the fault or negligence of the Contractor or (2) for which an equitable adjustment is provided for or excluded under any other provision of this Contract.

22.3 No claim under this clause shall be allowed (1) for any costs incurred more than 20 days before the Contractor shall have notified the Owner in writing of the act of failure to act involved (but this requirement shall not apply as to a claim resulting from a suspension order), and (2) unless the claim, in an amount stated is asserted in writing as soon as practicable after the termination of such suspension, delay, or interruption, but not later than the date of final payment under the Contract.

ARTICLE 23 FINAL INSPECTION AND ACCEPTANCE

23.1 Final inspection: When the Contractor notifies the Project Manager in writing that the work has been completed, the Owner will make the final inspection for the purpose of ascertaining that the work has been completed in accordance with the requirements of the Contract Documents.

23.2 Acceptance of the work: When the Owner has made the final inspection and has determined that the work has been completed in accordance with the Contract Documents, the Owner will accept the work. Immediately upon and after Final Acceptance, the Contractor will be relieved of the duty of maintaining and protecting the work as a whole. The Contractor will be relieved of his responsibility for injury to persons or property or damage to the work which occurs after Final Acceptance, except that the Contractor will not be relieved of his responsibility for injury to persons or property arising from his duties and obligations under Article 4, LIABILITY AND INDEMNIFICATION.

23.3 Final Acceptance shall be final and conclusive, and no further performance of work shall be required except with regards to latent defects, fraud or such gross mistakes as may amount to fraud, or with regard to the Owner's rights under any warranty or guarantee. All punch list items must be completed and building permits provided to Owner before final acceptance is issued.

23.4 Date of Substantial Completion for all Work shall be within the number of calendar days bid by the Contractor on the Bid proposal.

23.5 Date of Final Completion shall be the date specified on the Certificate of Final Completion.

**ARTICLE 24
PROGRESS PAYMENTS**

24.1 The Owner will make progress payments monthly as the work proceeds, on estimates approved by the Project Manager. Payment will be made within 15 days after progress estimates are approved by the Project Manager and Department Head. On request of the Project Manager, the Contractor shall furnish a detailed estimate of the total contract price each showing the amount included therein for each principal category of the work, to provide a basis for determining the amount of progress payments. In the preparation of estimates, the Owner, at its sole discretion, may authorize material delivered on the site and preparatory work done to be taken into consideration which is to be submitted at the pre-construction meeting.

24.2 In making such progress payments, five percent of the estimated amount will be retained until Final Acceptance of the Contract work; in addition, the Owner shall retain from all Progress payments an amount equal to all statutory claims filed against the Contractor. Also, whenever the work is substantially complete, the Owner if it considers the amount retained to be in excess of the amount adequate for its protection, may release to the Contractor all or a portion of such excess amount. Substantial completion as used in this Paragraph 24.2 shall mean the following: Substantial completion of the work or a portion thereof shall be when, as determined by both the Project Manager and the Owner, the construction is sufficiently completed in accordance with the Contract Documents and any modification thereto as provided in the Contract to permit the Owner to occupy the work or a portion of the work for the use which it is intended.

24.3 Material and work covered by progress payments shall become the sole property of the Owner. This provision shall not be construed as relieving the Contractor from the sole responsibility for material and work upon which payments have been made, the restoration of damaged work or as waiving the right of the Owner to require the fulfillment of the terms of the Contract.

**ARTICLE 25
PAYMENT TO SUBCONTRACTORS**

25.1 The Contractor shall pay all subcontractors for and on account of work performed by such subcontractors in accordance with the terms of their respective subcontract. Prior to final payment an unconditional lien waiver release form will be required by the Owner.

**ARTICLE 26
PAYMENT OF TAXES**

26.1 The price or prices for the work will include full compensation for taxes that the Contractor is or may be required to pay. The Contractor shall bear the risk of any added or increased taxes occurring during the prosecution of the work. A change in taxes shall under no circumstances entitle the Contractor to an adjustment under the Contract.

26.2 The Contractor's attention is directed to the fact that this project is exempt from payment of City of Greeley Sales and Use taxes, and such taxes must not be included in the amount of bid.

26.3 The Contractor shall pay all sales and use taxes required to be paid, shall maintain such records in respect of his work, which shall be separate and distinct from all other records maintained by the Contractor and shall be available for inspection by the Owner at any and all reasonable times, and shall furnish the Owner with such data, as may be necessary to enable the Owner to obtain any refunds of such taxes which may be available to the Owner under the laws, ordinances, rules or regulations applicable to such taxes. The Contractor shall require each of his subcontractors to pay all sales and use taxes required to be paid and to maintain such records and furnish the Contractor with such data as may be necessary to enable the Owner to obtain a refund of the taxes paid by such subcontractors.

ARTICLE 27 FINAL PAYMENT

27.1 After the Work has been accepted by the Owner, subject to the provisions of Article 11, WARRANTY OF WORK and Article 23, FINAL INSPECTION AND ACCEPTANCE of these General Conditions, a final payment due the Contractor under this Contract shall be paid upon the presentation of properly executed voucher and after the Contractor shall have furnished the Owner with a release of all claims against the Owner arising by virtue of this Contract, other than claims in stated amounts as may be specifically excepted by the Contractor from the operation of the release. If the Contractor's claim to amounts payable under the contract has been assigned under the assignment of Claims Act of 1940, as amended (31 U.S.C. 203, 41 U.S.C. 15), a release may also be required of the assignee.

27.2 If any mechanic's or material man's lien or notice of claim of such lien is filed or recorded against the project for labor, materials, supplies or equipment claimed to have been furnished to or incorporated into the Work, or for other alleged contribution thereto, the Owner will have the right to retain from payments otherwise due the Contractor, in addition to other amounts properly withheld under this Article or under other provisions of the Contract, an amount equal to such lien or liens claimed.

27.3 Further, the Owner will have the right to retain from final payment an amount equal to all liquidated damages claimed by the Owner.

27.4 Retainages held by the Owner for any state or federal statutory claim arising out of the project will be held by the Owner in addition to all retainages held under the provisions of the Contract.

ARTICLE 28 CHANGES

28.1 The Owner may, at any time, without notice to the sureties, by written notice or order designated or indicated to be a Change Notice or Change Order, make any change in the work within the general scope of the Contract in accordance with all of the Owner's processes and procedures whether or not set forth herein, including but not limited to changes:

28.1.1 In the Contract (including drawings and designs);

28.1.2 In the method or manner of performance of the work;

28.1.3 In Owner furnished facilities, equipment, materials, services, or site; or

28.1.4 Directing acceleration in performance of the work.

28.2 Any other order (which terms as used in Paragraph 28.2 of this Article shall include direction, instruction, interpretation, or determination) from the Project Manager, which causes any change, shall be treated as a Change Notice under this Article provided that the Contractor gives the Project Manager written notice stating the date, circumstances and source of the order, and that the Contractor regards the order as a Change Notice. The Contractor shall notify the Project Manager when he receives direction, instruction, interpretation or determination from any source which may cause any change in the work. Such notification shall be given to the Project Manager before the Contractor acts on said direction, instruction, interpretation or determination.

28.3 Except as herein provided, no order, statement, or conduct of the Architect/ Project Manager or any other person shall be treated as a change under this Article or entitle the Contractor to an equitable adjustment hereunder.

28.4 If any change under this Article causes an increase or decrease in the Contractor's cost of, or the time required for, the performance of any part of the Work under this Contract, whether or not changed by an order, an equitable adjustment will be made and the Contract modified accordingly by a written Change Order; provided, however, that except for claims based on errors in the Contract Documents, no claim for change under Paragraph 28.2 of this Article will be allowed for costs incurred more than 20 days before the Contractor gives written notice as herein required; and provided that in the case of errors in the Contract Documents for which the Owner is responsible, the adjustment will include increased cost, reasonably incurred by the Contractor in attempting to comply with such errors in the Contract Documents. No claim shall be made for the type of errors in the Contract Documents which are set forth in Article 2, INTERPRETATION.

28.5 If the Contractor intends to assert a claim for an equitable adjustment under this Article, he shall, within 30 days after receipt of a written Change Order under Paragraph 28.1 of this Article or the furnishing of a written notice under Paragraph 28.2 of this Article, submit to the Project Manager a written statement setting forth the general nature and monetary extent of such claim, unless this period is extended in writing by the Owner. The statement of claim hereunder may be included in the notice under Paragraph 28.2 of this Article.

28.6 No claim by the Contractor for an equitable adjustment hereunder will be allowed unless asserted as described in Paragraphs 28.4 and 28.5 above.

28.7 Payment will not be made under the provisions of this Article for such work or materials which are so required to be done or furnished in or about or for the performance of the Work and which are not mentioned, specified or indicated or otherwise provided for in this Contract or in the Contract Documents so far as such work or materials may be, in the opinion of the Project Manager, susceptible of classification under or reasonably inferred to be included in the Bid Items of the Bid Form.

28.8 In case the Contractor is ordered to perform work under this Article for which payments are not determined under Paragraph 28.7 of this Article, which in the opinion of the Owner it is impracticable to have performed by the Contractor's own employees, the Contractor will, subject to the approval of the Owner, be paid the actual cost to him of such work and, in addition thereto, a negotiated amount to cover the Contractor's superintendence, administration and other overhead expenses. The terms and conditions of any subcontract which the Contractor may propose to enter into in connection with work under the provision of this Article shall be subject to the written approval of the Project Manager before such subcontract is made. The contractor shall be responsible for the work of the subcontractors and shall be liable therefore as if he had performed the work directly.

28.9 In cases other than those described in Paragraphs 28.7 and 28.8 above, the Owner and the Contractor (on his own behalf and on behalf of his subcontractors) shall endeavor to negotiate a reasonable contract price and line adjustment in a Change Order on terms appropriate to the changed work. The Contractor will be required to submit a sufficiently detailed price proposal supported with sufficient documentation that (1) the Owner can determine that the proposal reflects all impacts on the Contract from work additions, deletions and modifications shown in the Change Notice being priced, (2) the proposed prices are set out in such a way that their reasonableness can be evaluated against prices based on adequate price competition, bid unit prices, established catalog or market prices of commercial items sold in substantial quantities to the general public, prices set by law or regulation, recognized published price lists and indices, independently developed cost estimates and other appropriate price comparisons, and (3) contract provisions relating to Contract changes costing over \$100,000.00 are complied with. If any prices or other aspects are conditional, such as on firm orders being made by a certain date or the occurrence or nonoccurrence of an event, the Contractor shall identify these aspects in his proposal. A negotiated Change Order shall set out prices, scheduling requirements, time extensions and all costs of any nature arising out of the issuance of a Change Notice except for those cost and time aspects explicitly reserved on the face of the Change Order. Except for these explicit reservations, the execution of a Change Order by both parties will be deemed accord and satisfaction of all claims of any nature arising from the issuance of the Change Notice negotiated.

28.10 In the event the Contractor and the Owner are unable to agree upon the Contractor's entitlement to an equitable adjustment or upon the amount thereof, or in the event that it is in the best interest of the Owner to have the Work proceed pending negotiation of amount of an equitable adjustment, the Owner may direct the Contractor to perform the Work in accordance with the Owner order, direction, instruction, interpretation, or determination, with any Contract price adjustments and progress payments for the Work to be determined on a Force Account basis in accordance with

Article 36. The Contractor shall continue diligently to perform the Contract in accordance with the Owner's order, direction, instruction, interpretation, or determination during negotiations with respect to the Contractor's entitlement to an equitable adjustment hereunder or to the amount of any Contract price adjustment or time extension. The Contractor and the Owner may agree on certain aspects of an equitable adjustment and take those aspects out of operation of Force Account provisions. In the event a mutually agreeable equitable adjustment cannot be made, the Contractor shall continue diligently to perform the orders as he proceeds with his remedies under Article 35, DISPUTES, and shall continue to receive compensation on a Force Account basis.

28.11 For contract changes, the Owner, State and Government or their representative shall have the audit and inspection rights as described below:

28.11.1 Where the agreed payment method for any contract changes is to be by cost reimbursement, time and material, labor hours or any combination thereof, the Contractor shall maintain and the Owner or its representatives shall have the right to examine books, records, documents and other evidence and accounting principles and practices sufficient to reflect properly all direct and indirect costs of whatever nature claimed to have been incurred and anticipated to be incurred for the performance of the contract changes under this sub article.

28.11.2 Contract changes exceeding \$100,000.00 in cost: For submitted cost and pricing data in connection with pricing a contract modification referred to in this sub article, unless such pricing is based on bid unit prices, adequate price competition, established catalog or market prices of commercial items sold in substantial quantities to the public, or prices set by law or regulation, the Owner or his representatives and the Comptroller General of the United States and his representatives who are employees of the United States shall have the right to examine all books, records, documents and other data of the Contractor related to the negotiation of or performance under the contract Change Orders for the purpose of evaluating the accuracy, completeness and currency of the cost or pricing data submitted. The right of examination shall extend to all documents necessary to permit adequate evaluation of the cost or pricing data submitted, along with the computations and projections used therein.

28.11.3 Contract changes exceeding \$10,000.00 but not \$100,000.00 in cost: The Owner or his representatives prior to the execution of any contract Change Order in this sub article or for a period of twelve months after execution shall, unless such pricing is based on bid unit prices, adequate price competition, established catalog of market prices or commercial items sold in substantial quantities to the public, or prices set by law or regulation, have the right to examine all books, records, documents, and other data of the Contractor relating to the negotiation and contract Change Order for the purpose of evaluating the accuracy, completeness, and currency of the data is submitted upon which negotiation is or has been based. To the extent the examination reveals inaccurate, incomplete or noncurrent data, the Project Manager may renegotiate the contract Change Order price based on such data.

28.11.4 Contract changes of less than \$10,000.00 in cost: The Owner may require from the Contractor appropriate documentation to support the prices being negotiated for contract changes

under this sub article, and may refuse to complete negotiations until satisfactory documentation is submitted.

28.11.5 Availability: The materials described in Paragraphs 28.11.1 and 28.11.2 above shall be available at the office of the Contractor at all reasonable times for inspection, audit or reproduction until three years from the date of final payment under this Contract and for records which relate to Article 35, DISPUTES, or litigations or the settlement of claims arising out of the negotiation or the performance of contract changes over 100,000.00, records shall be made available until such litigations or claims have been resolved.

28.11.6 The Contractor shall insert a clause containing all the provisions in this Paragraph 28.11, including this subparagraph 28.11.6, in all subcontracts hereunder except altered as necessary for proper identification of the contracting parties and Owner.

28.11.7 For the purposes of Paragraph 28.11 of this Article, costs shall include liquidated damages which would be assessed if extension(s) of time were not granted by contract Change Order.

28.11.8 The requirements of this audits and records article are in addition to other audit, inspection and record keeping provisions elsewhere in the Contract Documents.

28.12 Changes involving aggregate increases and decreases in excess of \$100,000.00 shall be subject to the following:

28.12.1 A change involves aggregate increases and decreases in excess of \$100,000.00 if the total value of work affected, without regard to the arithmetic sign, exceeds this amount; for example, a change order adding work in the amount of \$75,000.00 and deleting work in the amount of \$50,000.00 will be considered to involve aggregate increases and decreases of \$125,000.00.

28.12.2 The Contractor shall submit in support of all items not based upon unit prices or lump sum prices contained in the Contract or upon the established prices at which commercial items are sold in substantial quantities to the public, statements by his vendors that the prices charged the Contractor are not greater than the prices charged by the respective vendors to their most favored customers for the same items in similar quantities.

28.12.3 Price reductions for Defective Cost or Pricing Data--Pricing Adjustments: If any price, including profit and fee, negotiated in connection with any price adjustment was increased by any significant sums because:

28.12.3.1 The Contractor furnished cost or pricing data which were not complete, accurate, and current as certified in the Contractor's Certificate of Current Cost or Pricing Data;

28.12.3.2 A subcontractor, pursuant to Paragraph 28.13 of this Article entitled Subcontractor Cost or Pricing Data--Pricing Adjustments or any subcontract provision therein required, furnished costs or pricing data which were not complete, accurate, and current as certified in the Subcontractor's Certificate of Current Cost or Pricing Data;

28.12.3.3 The subcontractor or his prospective subcontractor furnished cost or pricing data which were required to be complete, accurate, and current and to be submitted to support a subcontract cost estimate furnished by the Contractor but which were not complete, accurate, and current as of the date certified in the Contractor's Certificate of Current Cost or Pricing Data; or

28.12.3.4 The Contractor or a subcontractor or his prospective subcontractor furnished any data, not within subparagraphs 28.12.3.1, 28.12.3.2, or 28.12.3.3 above, which were not complete, accurate, and current as submitted, the price shall be reduced accordingly and the Contract shall be modified in writing as may be necessary to reflect such reduction. Any reduction in the Contract Price due to defective subcontract data of a prospective subcontractor, when the subcontract was not subsequently awarded to such subcontractor, will be limited to the amount (plus applicable overhead and profit markup) by which the actual subcontract, or actual cost to the Contractor if there was no subcontract, was less than the prospective subcontract cost estimate submitted by the Contractor, provided the actual subcontract price was not affected by defective cost or pricing data.

28.13 Subcontract Cost of Pricing Data-- Pricing Adjustment:

28.13.1 When negotiating a change involving increases or decreases in excess of \$100,000.00, the Contractor shall require subcontractors hereunder to submit cost or pricing data under the following circumstances. Prior to award of any cost-reimbursement type, incentive or price redeterminable subcontract;

28.13.1.2 Prior to the award of any subcontract the price of which is expected to exceed \$100,000.00;

28.13.1.3 Prior to the pricing of any subcontract change modifications for which the price is expected to exceed \$100,000.00, except in the case of 28.13.1.2 and 28.13.1.3 where the price is based on adequate price competition, established catalog or market prices, commercial items sold in substantial quantities to the general public, or prices set by law or regulation.

28.13.2 The Contractor shall require subcontractors to certify to the best of their knowledge and belief that the cost and pricing data submitted under subparagraph 28.13.1 of this Article are accurate, complete, and current as of the date of execution, which date shall be as close as possible to the date of agreement on the negotiated price of the contract Change Order.

28.13.3 The Contractor shall insert the substance of Paragraph 28.13 of this Article, including this subparagraph 28.13.3, in each subcontract hereunder which exceeds \$100,000.00.

ARTICLE 29 PERFORMANCE BOND AND LABOR AND MATERIAL PAYMENT BOND

29.1 The Contractor shall furnish a Performance Bond in the amount equal to one hundred percent (100%) of the Contract Sum as security for the faithful performance of this Contract and also a Labor and Material Payment Bond in an amount not less than one hundred percent (100%) of the

Contract Sum or in a penal sum not less than that prescribed by State, or local law, as security for the payment of all persons performing labor on the Project under this Contract and furnishing materials in connection with this Contract. The Performance Bond and the Labor and Material Payment Bond may be in one or in separate instruments in accordance with local law and shall be delivered to the Owner not later than the date of execution of the Contract.

29.2 Performance Bonds, Labor and Material Payment Bonds and other such sureties shall provide that the surety and the Contractor are both jointly and severally liable and obligated under respective Bond or other surety agreement and shall incorporate acknowledge of applicable provisions of state law into all documents furnished in connection with the project.

ARTICLE 30 DIFFERING SITE CONDITIONS

30.1 The Contractor shall within 10 days of actual or constructive notice of a differing site condition, promptly, and before such conditions are disturbed, notify the Project Manager in writing of: (1) subsurface or latent physical conditions at the site differing materially from those indicated in the Contract Documents, or (2) unknown physical conditions at the site, of an unusual nature, differing materially from those ordinarily encountered and generally recognized as inherent in work of the character provided for in the Contract. The Project Manager will promptly investigate the conditions, and if such conditions materially differ and cause an increase or decrease in the Contractor's cost of, or the time required for, performance of any part of the work under the Contract, whether or not changed as a result of such conditions, an equitable adjustment may be made subject to Owner's approval and the Contract modified in writing accordingly.

30.2 No claim of the Contractor under this Article will be allowed unless the Contractor has given the notice required in Paragraph 30.1 of this Article.

30.3 No claim by the Contractor for an equitable adjustment hereunder will be allowed if asserted after final payment under this Contract.

ARTICLE 31 CONTRACTOR PROPOSALS

31.1 The Contractor may at any time submit to the Project Manager for his review proposed modifications to the Contract Documents, supported by a cost/price proposal. Upon acceptance of the proposed modifications by the Owner, a Change Order will be issued. Denial of the proposed modification will neither provide the Contractor with any basis for claim for damages nor release the Contractor from contractual responsibilities. An equitable adjustment in the form of a contract price reduction will be made if the change results in a reduction of the cost of performance and the Contractor will not be entitled to share in said savings unless the proposal is made under Paragraph 31.2 of this Article. Except as provided in Paragraph 31.2 of this Article, the Contractor will not be compensated for any direct, incidental or collateral benefits or savings the Owner receives as a result of the proposal.

31.2 Value Engineering Change Proposals: The Contractor may submit to the Project Manager one or more cost reduction proposals for changing the Contract requirements. The Proposals shall be based upon a sound study made by the Contractor indicating that the proposal:

31.2.1 Will result in a net reduction in the Total Contract amount;

31.2.2 Will not impair any essential function or characteristic of the Work such as safety, service life, reliability, economy of operation, ease of maintenance and necessary standardized features.

31.2.3 Will not require an unacceptable extension of the contract completion time; and

31.2.4 Will require a change in the Contract Documents and such change is not already under consideration by the Owner.

31.3 The Owner may accept in whole or in part any proposal submitted pursuant to the previous Paragraph 31.2 by issuing a Change Order which will identify the proposal on which it is based. The Change Order will provide for an equitable adjustment in the Contract Price and will revise any other affected provisions of the Contract Documents. The equitable adjustment in the Contract price will be established by determining the net savings resulting from the accepted change. The net savings resulting from the change will be shared between the Contractor and the Owner on the basis of 50 percent for the Contractor and 50 percent for the Owner and will be limited to this contract for any one Value Engineering Change Proposal. Net savings will be determined by deducting from the estimated gross savings, the Contractor's costs of developing and implementing the proposal (including any amount attributable to a subcontractor) and the estimated amount of increased costs to the Owner resulting from the change, such as evaluation, implementation, inspection, related items, and the Owner-furnished material. Estimated gross savings will include Contractor's labor, material, equipment, overhead, profit and bond. The Contract price will be reduced by the sum of the Owner's costs and share of the net savings. For the purpose of this Article, the applicable provisions of Article 28, CHANGES, shall be used to determine the equitable adjustment to the Contract price.

31.4 The Owner will not be liable for delay in acting upon, or for failure to act upon, any proposal submitted pursuant to Paragraph 31.2 of this Article. The decision of the Owner as to the Acceptance or rejection of any such proposal under the Contract will be final. The submission of a proposal by the Contractor will not in itself affect the rights or obligations of either party under the Contract.

31.5 The Contractor shall have the right to withdraw part or all of any proposal he may make under Paragraph 31.2 of this Article at any time prior to acceptance by the Owner. Such withdrawal shall be made in writing to the Project Manager. Each such proposal shall remain valid for a period of 60 days from the date submitted. If the Contractor wishes to withdraw the proposal prior to the expiration of the 60-day period, he will be liable for the cost incurred by the Owner in reviewing the proposal.

31.6 The Contractor shall specifically identify any proposals under Paragraph 31.2 of this Article with the heading "Value Engineering Change Proposal", or the proposal will be considered as made under Paragraph 31.1 of this Article.

31.7 The Contractor, in connection with each proposal he makes for a Contract Change Notice under this Article shall furnish the following information:

31.7.1 a description of the difference between the existing Contract requirement and the proposed change, and the comparative advantages and disadvantages of each, justification when a function or characteristic of an item is being altered, and the effect of the change on the performance of the end item;

31.7.2 an analysis and itemization of the requirements of the Contract which must be changed if the Value Engineering Change Proposal is accepted and a recommendation as to how to make each such change (e.g., a suggested specification revision);

31.7.3 a separate detailed cost estimate for both the existing Contract requirement and the proposed change to provide an estimate of the reduction in costs, if any, that will result from acceptance of the Value Engineering Change Proposal taking into account the costs of development and implementation by the Contractor;

31.7.4 a prediction of any effects the proposed change would have on collateral costs to the Owner such Government-furnished property costs, costs of related items, and costs of maintenance and operation;

31.7.5 a statement of the time by which a contract modification accepting the Value Engineering Change Proposal must be issued so as to obtain the maximum cost reduction, noting any effect on the contract completion time or delivery schedule; and

31.7.6 identification of any previous submission of the Value Engineering Change Proposal to the Owner, including the dates submitted, the numbers of contracts involved, and the previous actions by the Owner, if known.

ARTICLE 32 EXTENSION OF TIME

32.1 In addition to the provisions stated in Article 38, the Contractor will be granted an extension of time and will not be assessed liquidated damages for any portion of the delay in completion of the Work, performed under the latest approved progress schedule, arising from acts of God, war, fires, floods, epidemics, quarantine restrictions, freight embargoes, or weather more severe than the norm, provided that the aforesaid causes were not foreseeable and did not result from the fault or negligence of the Contractor, and provided further that the Contractor has taken reasonable precautions to prevent further delays owing to such causes, and has notified the Project Manager in writing of the cause or causes of delay within five days from the beginning of any such delay. Within 15 days after the end of the delay, the Contractor shall furnish the Project Manager with detailed

information concerning the circumstances of the delay, the number of days actually delayed, the appropriate Contract Document references, and the measures to be taken to prevent or minimize the delay. Failure to submit such information will be sufficient cause for denying the delay claims. The Owner will ascertain the facts and the extent of the delay, and its findings thereon will be final and conclusive to provisions under Article 35, DISPUTES. The extension of time granted for these reasons shall not be the basis for additional compensation for any costs incurred during the time of delay.

32.1.1 Every effort shall be made by the Contractor to complete the project within the "Contract Time". The "Contract Time" anticipates "Normal" weather and climate. The Contractor's schedule must anticipate normal adverse weather delays on all weather dependent activities. The following specifies the procedure for determining time extensions for unusually severe weather. Listed below are the anticipated numbers of calendar days lost to normal adverse weather for each month.

Monthly Anticipated Calendar Days Lost to Adverse Weather Conditions

JAN FEB MAR APR MAY JUN JUL AUG SEP OCT NOV DEC (7) (4) (4) (4) (6) (3) (4)
(2) (3) (3) (2) (5)

The above schedule of anticipated adverse weather days will constitute the base line for monthly (or portion thereof) weather time evaluations. It is assumed that the work will be carried out Mondays through Fridays (holidays excepted) unless and approved construction schedule or written authorization from the Owner indicates otherwise.

An actual adverse weather day must prevent work for 50 percent or more of the Contractor's workday. When the Contractor anticipates documenting a weather day, he/she shall first notify the Project Manager or his/her designee observing the construction to determine whether or not work can proceed or if work is delayed due to adverse weather or the effects thereof. If in agreement, the Contractor shall formally request a weather day in writing to the Owner's Project Manager or his/her designee. The Contractor shall also notify the Owner's Project Manager in writing or his/her designee of any disagreement as to whether or not work could have proceeded on a given date within 2 calendar days of that date. The final decision regarding an adverse weather day will be made by the Project Manager or his/her designee.

The number of workdays delayed due to adverse weather or the effects thereof will then be converted to Calendar Days. Weekends and holidays will only count as calendar day delays if a workday delayed due to adverse weather is counted before and after the weekend/holiday. The number of calendar days of delay due to adverse weather or the impact thereof will then be compared to the monthly adverse weather schedule above. The Contract time period will then be increased by change order for the number of calendar days that are in excess of the above schedule and a new Contract Completion day and date will be set.

32.1.2 An extension of time will not be granted for a delay caused by a shortage of materials, except Owner-furnished materials, unless the Contractor furnishes to the Project Manager documentary

proof that he has diligently made every effort to obtain such materials from every known source within reasonable reach of the Work. The Contractor shall also submit proof that the inability to obtain such materials when originally planned did in fact cause a delay in final completion of the Work which could not be compensated for by revising the sequence of his operations. Only the physical shortage of material will be considered under these provisions as a cause for extension of time. No consideration will be given to any claim that material could not be obtained at reasonable, practical, or economical costs, unless it is shown to satisfaction of the Project Manager that such material could have been obtained only at exorbitant prices, entirely inconsistent with current rates taking into account the quantities involved and the usual practices in obtaining such quantities.

32.2 A Change Order will be furnished to the Contractor within a reasonable period of time after approval of a request for extension of time, specifying the number of days allowed, if any, and the new date for completion of the Work or specified portions of the Work.

32.3 See also Article 38, TERMINATION FOR DEFAULT--DAMAGES FOR DELAY--TIME EXTENSIONS.

ARTICLE 33 NOTICE OF POTENTIAL CLAIM

33.1 The Contractor will not be entitled to additional compensation otherwise payable for an act or failure to act by the Owner, the happening of any event or occurrence, or any other cause, unless he shall have given the Project Manager a written notice of potential claim therefore as specified in this Article.

33.2 The written notice of potential claim shall set forth the reasons for which the Contractor believes additional compensation will or may be due, the nature of the costs involved, and insofar as possible, the amount of the potential claim. If based on an act or failure to act by the Owner, such notice shall be given to the Project Manager prior to the time that the Contractor has started performance of work giving rise to the potential claim for additional compensation. Notice shall be given within five days after the happening of the event or occurrence giving rise to the potential claim.

33.3 It is the intention of this Article that differences between the parties arising under and by virtue of the contract shall be brought to the attention of the Project Manager at the earliest possible time in order that such matters may be settled, if possible, or other appropriate action promptly taken.

33.4 The notice requirements of this Article are in addition to those required in other Articles of the General Conditions.

ARTICLE 34 SUBMITTAL OF CLAIMS

34.1 Claims filed by the Contractor shall contain sufficient detail to enable the Owner to ascertain the basis and amount of said claims. The Owner will review and evaluate the Contractor's claims. It will be the responsibility of the Contractor to furnish when requested by the Project

Manager such further information and details as may be required to determine the facts or contention involved in his claims. Failure to submit such information and details will be sufficient cause for denying the Contractor's claims.

34.2 Each claim the Contractor may make for equitable adjustment on account of delay for any cause shall be accompanied by a progress schedule reflecting the effects of the delay and proposals to minimize these effects. If no progress schedule has been submitted to the Project Manager reflecting conditions prior to the delay for which relief is sought, then a progress schedule so reflecting these conditions shall be prepared and submitted with the claim.

34.3 Depending upon the grounds for relief and the nature of relief sought, additional submittals and conditions upon submitting claims may be required elsewhere in these General Conditions.

34.4 In no event shall claims be made after final payment is made under Article 27, FINAL PAYMENT, of these General Conditions.

34.5 Inasmuch as notice of potential claim requirements of Article 33, NOTICE OF POTENTIAL CLAIM, are intended to enable the Project Manager to investigate while facts are fresh and to take action to minimize or avoid a claim which might be filed thereafter, the Contractor's failure to make the required notice on time is likely to disadvantage the Owner. Therefore no claim for which a notice of potential claim is required will be considered unless the Contractor has complied with the notice of Article 33, NOTICE OF POTENTIAL CLAIM.

ARTICLE 35 DISPUTES

35.1 General: Notwithstanding any other provisions of this Contract, disputes and disagreements by and between the Owner and the Contractor shall be resolved through progressive, sequential process of negotiation, mediation, and in certain cases, arbitration. For contracts which are for \$250,000 or less, amounts in dispute which are less than \$10,000 shall not progress beyond negotiation and shall ultimately be decided by the Owner if not by mutual agreement. For contracts which are for more than \$250,000, amounts in dispute which are less than \$25,000 should not progress beyond negotiation. For all contracts, amounts in dispute greater than those amounts set forth above, but less than \$100,000 shall be resolved through a sequential process of negotiation, mediation, and binding arbitration. Amounts in dispute which are \$100,000 or more shall be resolved through a sequential process of negotiation, mediation, and thence either arbitration or litigation.

35.2 Negotiation: In the event of disputes, unsettled claims, questions or disagreements between the contractor and the City relating to or arising out of the provisions of this Contract, the representatives of those parties shall meet promptly in recognition of mutual interests and in a good faith effort to resolve the dispute. Either the Contractor or the City shall arrange for this meeting at a time and place within the City of Greeley, mutually acceptable to both parties, within fifteen (15) days of notification of the dispute, unsettled claim, question, or disagreement between the parties. Seven (7) days prior to the meeting, the initiating party shall deliver to the other party, a written and complete

summary of the evidence and arguments substantiating its claim. If the parties do not reach a solution within thirty (30) days after said initial meeting, then upon notice of either party to the other, the dispute, claim, question, or difference, may be referred to a mediator pursuant to Section 35.3. The parties can extend the negotiation period by mutual written agreement.

35.3 Mediation: If the dispute, claim, question, or difference is not resolved by negotiation within thirty (30) days after the initial meeting between the parties or within the extended period agreed upon, the parties agree to next request that the American Arbitration Association provide a mediator to assist the Owner and Contractor in resolving the dispute, claim, question, or difference. The rules of mediation shall be the Construction Industry Mediation Rules of the American Arbitration Association. A different mediation/dispute resolution agency may be selected for mediation upon the mutual written agreement between the parties. The dispute resolution agency shall select a qualified mediator who shall have a background in construction. The selected mediator may be rejected by the parties only for bias. The mediator shall have thirty (30) days from the time of appointment to meet with the parties and sixty (60) days from the time of the appointment to resolve the dispute unless the parties mutually consent to an extension of the sixty day deadline. All reasonable fees, costs, and expenses of the mediator, the mediator's association and the mediation agency, shall be borne equally by the parties. Each party shall bear the expense of its own counsel, experts, witnesses, and preparation and presentation of proofs at mediation.

The Contractor shall not cause a delay of work during mediation proceedings except by mutual agreement. All mediation proceedings shall be conducted in the City of Greeley, unless an alternate location is agreed upon in writing by the Owner and the Contractor.

Amounts in dispute which are less than \$10,000 shall not progress beyond mediation.

35.4 Litigation prerequisites: The procedures enumerated in Sections 35.2 and 35.3 shall be a prerequisite to the filing of any litigation between the parties to the Contract. Failure of the Contractor to follow the provisions of Section 35.2 and Section 35.3 shall be a complete defense, and grounds for immediate dismissal of any litigation filed prior to Contractor engaging in negotiation and mediation with the City of Greeley as provided above. Litigation may be filed only if the amount in dispute is \$100,000 or more. In the event litigation is filed by and between the parties after mediation, venue and jurisdiction of any and all suits and causes of action in connection with this Contract shall lie exclusively in Weld County, Colorado.

35.5 Arbitration: After mediation, instead of litigation, any remaining unresolved controversy or claim arising out of or relating to this Contract or the performance or breach thereof, may be settled by arbitration in accordance with the Construction Industry Arbitration Rules of the American Arbitration Association. For amounts in dispute which are \$100,000 or more, arbitration shall be engaged only upon mutual written agreement by the Owner and the Contractor, and the written agreement shall specify whether the arbitration shall be binding or nonbinding; however, amounts in dispute which are less than \$100,000 shall necessarily be settled by binding arbitration. The sole arbitrator shall be appointed by the Arbitration Association, unless a different arbitrator or dispute resolution agency is mutually agreed upon. The award of the arbitrator shall be accompanied by a

reasoned opinion, and shall include findings of fact and conclusions. All fees and expenses of the arbitration, including the expense of each party's counsel, experts, witnesses, and preparation and presentation of proofs, shall be borne by the party against whom arbitration judgment is made.

35.6 Litigation: Each party shall bear its own litigation fees and expenses, including the expense of its counsel, experts, witnesses, and preparation and presentation of proofs, regardless of the prevailing party.

ARTICLE 36 FORCE ACCOUNT WORK

36.1 This Article shall become operative upon failure of the Contractor and the Owner to arrive at an amount of compensation under Article 28, CHANGES. In the event that no equitable adjustment is arrived at either by mutual agreement or pursuant to the Article 35, DISPUTES, the compensation paid hereunder will be the total compensation.

36.2 Work Performed by or for Contractor: The Contractor will be paid for labor, materials, and equipment as hereinafter provided, except where agreement has been reached to pay in accordance with Paragraph 36.3 of this Article. The following percentages, as full compensation for profit, overhead and small tools, will be added to the totals computed as provided in subparagraphs 36.2.1 through 36.2.3 of this Article.

Labor 25 percent
Materials 20 percent
Equipment 10 percent

Labor, materials, and equipment shall be furnished by the Contractor or by a subcontractor. When work paid on a force account basis is performed by forces other than the Contractor's, the Contractor shall reach agreement with such other forces as to the distribution of the payment made by the Owner for such work and, except as specified herein, no additional payment therefore will be made by the Owner by reason of performance of work by a subcontractor or by others. In addition to the markups, if any, for labor, equipment, and materials, for subcontracted work, the Contractor may add an additional five percent markup. The cost of subcontracted work will be the actual cost to the contractor for work performed by a subcontractor as computed in accordance with this Paragraph 36.2 and its subparagraphs 36.2.1, 36.2.2, and 36.2.3.

36.2.1 Labor: The cost of labor used in performing the work, whether the employer is the Contractor or a subcontractor, will be the sum as determined on the basis of the following three subparagraphs:

36.2.1.1 The gross actual wages, including income tax withholdings but not including employer payments to or on behalf of workmen for health and welfare, pension, vacation, insurance and similar purposes.

36.2.1.2 To the gross actual wages, as defined in the previous subparagraph,

36.2.1.1, will be added a percentage based upon current State and Federal laws and applicable labor contracts concerning payments made to or on behalf of workmen other than actual wages, which percentage will constitute full compensation for all payments imposed by State and Federal laws and for all other payments made to or on behalf of the workmen, other than actual wages as defined in the previous subparagraph 36.2.1.1 and the subsistence and travel allowance as specified in the following subparagraphs 36.2.1.3. The Contractor shall compute a separate percentage for each craft, or a composite percentage for all crafts, if so approved by the Owner. Computed percentages shall be submitted to the Project Manager for approval by the Owner.

36.2.1.3 Subsistence and travel allowance paid to workmen as required by established agreements.

36.2.1.4 The charges for labor shall include all classifications up to but not including foremen, and when authorized by the Owner, shall include foremen engaged in the actual and direct performance of the work. Labor charges shall not include charges for assistant superintendents, office personnel, timekeepers, and maintenance mechanics, unless authorized by the Owner in advance of the start of work.

36.2.2 Materials: The cost of materials required for the accomplishment of the work will be delivered cost to the purchaser, whether contractor or subcontractor, from the supplier thereof, except as the following are applicable:

36.2.2.1 If a cash or trade discount by the actual supplier is offered or available to the Contractor, it shall be credited to the Owner notwithstanding the fact that such discount may not have been taken.

36.2.2.2 If materials are procured by the Contractor by a method which is not a direct purchase from and a direct purchase from and a direct billing by the actual supplier, the cost of such materials will be deemed to be the price paid to the actual supplier, as determined by the Owner. No additional markup for supplier work will be allowed except to the extent of actual cost to the Contractor in handling the material, not to exceed five percent of the price paid to actual supplier.

36.2.2.3 If the materials are obtained from a supply or source owned wholly or in part by the Contractor, payment therefore will not exceed the price paid for similar materials furnished from said source on Contract Items or the current wholesale price for such materials delivered to the work site, whichever price is lower.

36.2.2.4 If the cost of the materials is, in the opinion of Owner, excessive, then the cost of such materials will be deemed to be the lowest current wholesale price at which such materials are available in the quantities concerned, delivered to the job site, less discounts as provided in subparagraph 36.2.2.1 of this Article.

36.2.2.5 If the Contractor does not furnish satisfactory evidence of the cost of such materials from the actual supplier thereof, the cost will be determined in accordance with subparagraph 36.2.2.4 of this Article.

36.2.2.6 The Contractor shall have no claims for costs and profit on Owner-furnished materials.

36.2.3 Equipment: The Contractor will be paid for the use of contractor-owned or rented equipment at the rental rates shown in the Colorado State Department of Highways Construction Equipment Rental Rate Schedule, except as modified below, which edition shall be the latest edition in effect at the time of commencement of the Force Account work. For equipment used in excess of eight hours per day, the rental rate shall be 60 percent of the listed hourly rate. If it is deemed necessary by the Contractor to use equipment not listed in the C.D.O.H. Construction Equipment Rental Rate Schedule, the Contractor shall furnish the necessary cost data and paid invoices to the Project Manager for his use in establishment of such rental rate.

36.2.3.1 The rates paid as above provided will include the cost of fuel, oil, lubricants, supplies, small tools, necessary attachments, repairs and maintenance, depreciation, storage, insurance and incidentals.

36.2.3.2 Equipment operators will be paid for as stipulated in subparagraph 36.2.1 of this Article.

36.2.3.3 Equipment shall be in good working condition and suitable for the purpose for which the equipment is to be used.

36.2.3.4 Unless otherwise specified, manufacturer-approved modifications shall be used to classify equipment for the determination of applicable rental rates. Equipment which has no direct power unit shall be powered by a unit of at least the minimum rating recommended by the manufacturer of that equipment.

36.2.3.5 Individual pieces of equipment or tools having a net individual value of \$300 or less, whether or not consumed by use, will be considered to be small tools and no payment will be made therefore.

36.2.3.6 Compensation will not be allowed while equipment is inoperative due to breakdown. Except as specified in paragraph 36.2.3.7 of this Article, time will be computed in half and full hours. In computing the time for use of equipment, less than 30 minutes shall be considered one half hour.

36.2.3.7 Equipment at the Work Site: The time to be paid for use of equipment on the work site will be the time the equipment is in operation on the force account work being performed. The time will include the time required to move the equipment to location of the force account work and return it to the original location or to another location requiring no more time than that required to return it to its original location. Moving time will not be paid for if the equipment is used at the site of the force account work on other than such force account work. Loading and transporting costs will be allowed, in lieu of moving time, when the equipment is moved by means other than its own power. No

payment for loading and transporting will be made if the equipment is used at the site of the force account work on other than such force account work.

36.3 Special Items of Work: If the Owner and the Contractor, by agreement, determine that (a) an item of force account work does not represent a significant portion of the total Contract price, and (b) such items of work cannot be performed by the forces of the Contractor or the forces of any of his subcontractors, and (c) it is not in accordance with the established practice of the industry involved to keep the records which the procedure outlined in Paragraph 36.2 of this Article would require, charges for such special force account work items may be made on the basis of invoices for such work without complete itemization of labor, materials, and equipment rental costs. To such invoiced price, less a credit to the Owner for any cash or trade discount offered or available, will be added five percent of the discounted price, in lieu of the percentages provided in Paragraph 36.2 of this Article. In no event will the price paid exceed the current fair market value of such work plus five percent.

6.4 Records: The Contractor shall maintain his records to provide a clear distinction between the direct costs of work paid for on a force account basis and costs of other operations.

36.4.1 The Contractor shall prepare and furnish to the Project Manager, on the following work day, report sheets in duplicate of each day's work paid for on a force account basis. The daily report sheets shall itemize the materials used and shall cover the direct cost of labor and the charges for equipment, whether furnished by the Contractor, subcontractor, or other forces, except for charges described in Paragraph 36.3 of this Article. The daily report sheets shall provide names or identifications and classifications of workmen and the hourly rate of pay and hours worked. In addition, a report of the size, type and identification number of equipment and hours operated shall be furnished to the Project Manager. Daily report sheets shall be signed by the Contractor or his authorized agent.

36.4.2 Material changes shall be substantiated by valid copies of vendor's invoices or conformed copies, certified true by the Contractor. Such invoices shall be submitted with the daily report sheets. Should the vendor's invoices not be submitted within 20 days after the date of delivery of the material or 15 days after acceptance of the work, whichever comes first, the Owner reserves the right to establish the cost of such materials at the lower current wholesale prices at which such materials are available in the quantities concerned delivered to the location of the work, less any discounts provided in subparagraph 36.2.1. of this Article.

36.4.3 The Project Manager will compare his records with the daily report sheets furnished by the Contractor, make any necessary adjustment and compile the costs of work paid for on a force account basis on daily force account work report forms. When these daily reports are agreed upon and signed by the Project Manager, they shall become the basis of payment for the work performed, but shall not preclude subsequent adjustment based on a later audit.

36.4.4 The Contractor's original cost records pertaining to work paid for on a force account basis shall be retained and shall be open to inspection and audit as required by Article 28, CHANGES, and any other provisions of the Contract.

36.5 If, in the Project Manager's opinion, the Contractor or any of his subcontractors, in performing Force Account work, is not making efficient use of labor, material or equipment or is proceeding in a manner which makes Force Account work unnecessarily more expensive to the Owner, the Project Manager may, in whole or part, direct the Contractor in the deployment of labor, material and equipment. By way of illustration, inefficiency may arise in the following ways: (1) the timing of the work, (2) the use of unnecessary labor or equipment, (3) the use of a higher percentage of apprentices than in non-force account work, (4) failure to procure materials at the lowest price, or (5) using materials of quality higher than necessary.

ARTICLE 37 TERMINATION FOR CONVENIENCE OF THE OWNER

37.1 The performance of Work under this contract may be terminated by the Owner in accordance with this Article in whole, or from time to time in part, whenever such termination is in the best interest of the Owner. Such termination shall be effected by delivery to the Contractor of a Notice of Termination specifying the extent to which performance of work under the Contract is terminated, and the date upon which such termination becomes effective.

37.2 After receipt of a Notice of Termination, and except as otherwise directed by the Owner, the Contractor shall:

37.2.1 Stop work under the Contract on the date and to the extent specified in the Notice of Termination.

37.2.2 Place no further orders or subcontracts for materials, services or facilities, except as may be necessary for completion of such portion of the work under the Contract as is not terminated;

37.2.3 Terminate all orders and subcontracts to the extent that they relate to the performance of work terminated by the Notice of Termination;

37.2.4 Assign to the Owner in the manner, at the times, and to the extent directed by it, all of the rights, title and interest of the Contractor under the orders and subcontracts so terminated, in which case the Owner will have the right, in its discretion, to settle or pay any or all claims arising out of the termination of such orders and subcontracts;

37.2.5 Settle outstanding liabilities and claims arising out of such termination of orders and subcontracts, with the approval or ratification of the Owner to the extent it may require, which approval or ratification shall be final for the purposes of this Article;

37.2.6 Transfer title and deliver to the Owner in the manner, at the times, and to the extent, if any directed by it, (a) the fabricated or unfabricated parts, work in process, completed work, supplies and other material procured as part of, or acquired in connection with the performance of, the work terminated by the Notice of Termination, and (b) the completed or partially completed plans,

drawings, information, and other property, which, if the Contract had been completed, would have been required to be furnished to the Owner;

37.2.7 Use his best efforts to sell, in the manner, at the times, to the extent, and at the price or prices direction or authorized by the Owner, property of the types referred to in (37.2.5) above; provided, however, that the Contractor (a) shall not be required to extend credit to any purchaser and (b) may acquire any such property under the conditions prescribed by and at a price or prices approved by the Owner; provided further that the proceeds of any such transfer or disposition will be applied in reduction of any payments to be made by the Owner to the contractor under this Contract or will otherwise be credited to the price or cost of the work covered by this Contract or paid in such other manner as the Owner may direct;

37.2.8 Complete performance of each part of the work as shall not have been terminated by the Notice of Termination; and

37.2.9 Take such action as may be necessary, or as the Project Manager may direct, for the protection and preservation of the property related to this Contract which is in the possession of the Contractor and in which the Owner has or may acquire an interest.

37.3 After receipt of a Notice of Termination, the Contractor shall submit to the Project Manager his termination claim, in the form and with certification prescribed by the Owner. Such claims shall be submitted promptly but in no event later than the earliest of the following: (1) one year from the effective date of termination or (2) thirty days after the remainder of the project has been accepted by the owner.

37.4 Subject to the provision of Paragraph 37.3, the contractor and the Owner may agree upon the whole or any part of the amount or amounts to be paid to the Contractor by reason of the total or partial termination of work pursuant to this Article, which amount or amounts may include an allowance for profit on work done; provided that such agreed amount or amounts, exclusive of settlement costs, shall not exceed the total contract price as reduced by the amount of payments otherwise made and as further reduced by the Contract price of work terminated. The Contract will be amended accordingly, and the Contractor will be paid the agreed amount.

37.5 In the event of failure of the Contractor and the Owner to agree, as provided in Paragraph 37.4, upon the whole amount to be paid the Contractor by reason of the termination of work pursuant to this Article, the Owner will pay the Contractor the amounts determined by the Owner as follows, but without duplication of any amounts agreed upon in accordance with Paragraph 37.4;

37.5.1 With respect to contract work performed prior to the effective date of the Notice of Termination, the total (without duplication of any items) of:

37.5.1.1 The cost of such work;

37.5.1.2 The cost of settling and paying claims arising out of the termination of work under subcontracts or orders as provided in subparagraph 37.2.5 above, exclusive of the amounts paid or

payable on account of supplies or materials delivered or services furnished by the subcontractor prior to the effective date of the Notice of Termination of work under this Contract, which amounts shall be included in the cost on account of which payment is made under 37.5.1 above.

37.5.1.3 A sum, as profit on 37.5.1.1 above, determined by the Owner to be fair and reasonable; provided, however, that if it appears that the Contractor would have sustained a loss on the entire Contract had it been completed, no profit shall be included or allowed under this subparagraph 37.5.1.3 and an appropriate adjustment shall be made by reducing the amount of the settlement to reflect the indicated rate of loss.

37.5.2 The reasonable cost of the preservation and property incurred pursuant to subparagraph 37.2.9 and any other reasonable cost incidental to termination of work under this Contract, including expense incidental to the determination of the amount due to the Contractor as the result of the termination of work under this Contract.

37.5.3 The total sum to be paid to the contractor under paragraph 37.5.1 above will not exceed the total contract price as reduced by the amount of payments otherwise made and as further reduced by the Contract price of the work terminated.

37.6 In arriving at the amount due the Contractor under this Article, there will be deducted (1) any claim which the Owner may have against the Contractor in connection with this Contract, (2) the agreed price for, or the proceeds of sale, of materials, supplies or other things acquired by the contractor or sold, pursuant to the provisions of this Article, and not otherwise recovered by or credited to the Owner and (3) the full amount of any statutory or other claim against the Contractor filed with the Owner.

37.7 Unless otherwise provided for in this Contract, or by applicable statute, the Contractor, from the effective date of termination and for a period of three years after final settlement under this Contract, shall preserve and make available to the Owner at all reasonable times at the office of the Contractor but without direct charge to the Owner, all his books, records, documents, electronic/digital media and other evidence bearing on the costs and expenses of the Contractor under this Contract and related to the work terminated hereunder, or to the extent approved by the Owner, or other authentic reproductions thereof.

37.8 The Contractor shall insert in all subcontracts that the subcontractor shall stop work on the date of and to the extent specified in a Notice of Termination from the Owner and shall require that any tier subcontractors insert the same provision in any tier subcontracts.

37.9 Under no circumstances is the Contractor entitled to anticipatory, unearned profits or consequential damages as a result of a termination or partial termination under this Article.

ARTICLE 38
TERMINATION FOR DEFAULT

38.1 If, in the opinion of the Owner, the Contractor has failed to prosecute work, the Owner will notify the Contractor. The Contractor will then have 5 days to remedy the failure to prosecute work or to obtain the Owner's authorization for the delay or an extension of time as set forth in Article 32.

38.2 If the Contractor refuses or fails after reasonable notice as set forth above to prosecute Work, or any separable part thereof, with such diligence as will insure its completion within the time specified in this Contract, or refuses or fails to complete said Work within such time, the Owner may, by written notice to the Contractor, terminate for default his right to proceed with the Work or such part of the Work as to which there has been unauthorized delay. In such event the Owner may take over the work and prosecute the same to completion, by Contractor or otherwise, and may take possession of and utilize in completing the Work such materials, appliances, and plant as may be on the Work Site and necessary therefore. Whether or not the Contractor's right to proceed with the Work is terminated, he and his sureties shall be liable for any damage to the Owner resulting from his refusal or failure to complete the Work in the specified time.

38.3 If the Owner so terminates the Contractor's right to proceed, the resulting damage will consist of liquidated damages until such time as may be required for final completion of the Work together with any increased costs incurred by the Owner in completing the Work as further set forth in Article 41.

38.4 If, after Notice of Termination of the Contractor's right to proceed under the provisions of this Article, it is determined for any reason that the Contractor was not in default under the provisions of this Article or that the Contractor was entitled to an extension of time under Article 32, EXTENSION OF TIME, the rights and obligations of the parties shall be the same as if the Notice of Termination had been issued pursuant to Article 37, TERMINATION FOR CONVENIENCE OF THE OWNER.

38.5 The right to terminate for default and any other rights and remedies of the Owner provided in this clause are in addition to any other rights and remedies provided by law or under this Contract.

ARTICLE 39
TERMINATION OF RIGHT TO PROCEED FOR CERTAIN DEFAULTS

39.1 In addition to the Owner's right to terminate for default under other Articles of this Contract, the Owner will have the right to terminate the Contractor's performance of work in whole or in part for default for any of the following reasons:

39.1.1 The Contractor's or subcontractor's performance of work is in violation of the terms of the Contract.

39.1.2 The Contractor or subcontractor has violated an authorized order or requirement of the Owner.

39.1.3 Abandonment of Contract.

39.1.4 Assignment or subcontracting of the Contract or any work under the Contract without approval of the Owner.

39.1.5 Bankruptcy or appointment of a receiver for the Contractor's property.

39.1.6 Performance of the Contractor in bad faith.

39.1.7 Contractor allowing any final judgment to stand against him for a period of 48 hours (excluding weekends and legal holidays).

39.2 If, in the opinion of the Owner, the Contractor is in default of the Contract, the Owner will notify the Contractor. If the Contractor fails to remedy or commence to remedy the default within five days after receipt of such notice, the Owner may terminate the Contractor's right to proceed with the Work or that portion of the Work which the Owner determines is most directly affected by the default.

39.3 If, after Notice of Termination of Contractor's right to proceed under this Article it is determined for any reason Contractor was not in default, the rights and obligations of the parties shall be the same as if the Notice of Termination had been issued pursuant to Article 37, TERMINATION FOR CONVENIENCE OF THE OWNER.

ARTICLE 40 RIGHTS AND OBLIGATIONS OF PARTIES AT TERMINATION FOR DEFAULTS

40.1 This Article shall apply to terminations for defaults covered in Article 15, 38, and 39 of these General Conditions.

40.2 On receipt of a Notice of Termination from the Owner, the Contractor shall:

40.2.1 Stop all work under the Contract on the date and to the extent specified in the Notice of Termination.

40.2.2 Place no further orders or subcontracts for materials, equipment or services except as they relate to the performance of work covered by the Notice of Termination.

40.2.3 Cancel or terminate all orders or subcontracts to the extent that they relate to the performance of work covered by the Notice of Termination.

40.2.4 Comply with all other requirements of the Owner as may be specified in the Notice of Termination.

40.3 Upon the Owner termination of the Contractor's right to proceed with the Work because of the Contractor's default under the Contract, the Owner will have the right to complete the Work by whatever means and method it deems advisable. The Owner shall have the right to take possession of and use any or all the Contractor's materials, plat, tools, equipment and property of any kind provided by or on behalf of the Contractor for the purpose of the Work, or a portion of them, without being responsible to the Contractor for fair wear and tear. The Contractor shall have no rights in such property during their use by the Owner. The Owner will not be required to obtain the lowest prices for completing the Work but shall make such expenditures as, in the Owner's sole judgment, best accomplish such completion.

40.4 The expense of completing the Work, together with a reasonable charge for engineering, managerial and administrative services, as certified by the Owner, will be charged to the Contractor and the expense so charged will be deducted by the Owner out of such monies as may be due or may at any time thereafter become due to the Contractor. In case such expense is in excess of the sum which otherwise would have been payable to the Contractor under the Contract, the Contractor or his surety shall promptly pay the amount of such excess to the Owner upon notice from the Owner of the excess so due. The Owner may, in its sole discretion, withhold all or any part of any progress payments otherwise due the Contractor until completion and final settlement of the Work covered by the Notice of Termination of Contractor's right to proceed.

40.5 The Contractor shall insert in all subcontracts that the subcontractor will stop work on the date of or to the extent specified in a Notice of Termination from the Owner and shall require the subcontractors to insert the same provision in any tier subcontracts.

40.6 The Contractor shall immediately upon receipt communicate any Notice of Termination issued by the Owner to the affected subcontractors and suppliers at any tier.

40.7 Rights of Surety: The Surety on the Performance Bond provided for in this Contract shall not be entitled to take over the Contractor's performance of work in case of termination under this Article, except with the consent of the Owner.

ARTICLE 41 LIQUIDATED DAMAGES

41.1 Time is of the essence of the Contract. In the event the Contractor fails to achieve Substantial Completion of the Work within the Contract Time, or fails to meet any other time requirement or the time limit set forth in the Contract, after due allowance for any extension or extensions of time made in accordance with the Contract, the Contractor shall pay to the Owner as fixed, agreed and liquidated damages, pursuant to the clause of the Contract entitled TERMINATION FOR DEFAULT—DAMAGES FOR DELAY—TIME EXTENSIONS, the sum of \$500.00 for each

calendar day of delay unless otherwise stated in the Special Provisions. Such liquidated damages shall be assessed for each and every day that the Contractor shall be in default. The Owner shall have the right to deduct said liquidated damages from any amount due or that may become due the Contractor, or to collect such liquidated damages from the Contractor or its surety.

41.2 Liquidated damages in the amount stipulated do not include any sums of money to reimburse the City for actual damages which may be incurred between Substantial Completion and Final Completion because of the Contractor's failure to achieve Final Completion within the Contract Time. For such delay in Final Completion, the Contractor shall reimburse the City, as a mitigation of City damages and not as a penalty, those administrative costs incurred by the City as a result of such failure.

41.3 Liquidated damages in the amounts stipulated do not include any sums of money to reimburse the City for extra costs which the City may become obligated to pay on other contracts which were delayed or extended because of the Contractor's failure to complete the Work within the Contract Time. Should the City incur additional costs because of delays or extensions to other contracts resulting from the Contractor's failure of timely performance, the City will assess these extra costs against the Contractor, and these assessments will be in addition to the stipulated liquidated damages.

41.4 The City reserves all of its rights to actual damages from the Contractor for injury or loss suffered by the City from actions or omissions of the Contractor, including but not limited to any other breach or default of the Contract, outside of the scope of the above sections.

ARTICLE 42 USE AND POSSESSION PRIOR TO COMPLETION

42.1 The Owner shall have the right to take possession of or use any completed or partially completed parts of the Work. Such possession or use will not be deemed an acceptance of Work not completed in accordance with the Contract. While the Owner is in such possession, the Contractor, notwithstanding the provisions of Article 18, DAMAGE TO WORK AND RESPONSIBILITIES FOR MATERIALS, will be relieved of the responsibility for loss or damage to the work other than that resulting from the Contractor's fault or negligence or breach of warranty. If such prior possession or use by the Owner delays the progress of the Work or causes additional expense to the Contractor, an equitable adjustment in the Contract price or the time of completion will be made, and the Contract will be modified in writing accordingly.

ARTICLE 43 RIGHTS IN SHOP DRAWINGS AND WORKING DRAWINGS

43.1 Shop Drawings and Working Drawings, submitted to the Project Manager by the Contractor, subcontractor or any lower tier subcontractor pursuant to the Work, may be duplicated by the Owner and the Owner may use and disclose, in any manner and for any purpose, Shop Drawings and Working Drawings delivered under this Contract.

43.2 This Article, including this Paragraph 43.2, shall be included in all subcontracts hereunder at all tiers.

ARTICLE 44 PATENT AND COPYRIGHT

44.1 The Contractor shall warrant that the materials, equipment or devices used on or incorporated in the Work shall be delivered free of any rightful claim of any third party for infringement of any United States patent or copyright. If notified promptly in writing and given authority, information and assistance, the Contractor shall defend, or may settle, at his expense, any suit or proceeding against the Owner or the Project Manager based on a claimed patent or copyright infringement which would result in a breach of his warranty. The Contractor shall pay all damages and costs awarded therein against the Owner or the Project Manager due to such breach. If any use of materials, equipment or devices is held to constitute an infringement and such use is enjoined, the Contractor shall, at his expense and option, either procure for the Owner the right to continue using said materials, equipment or devices, or replace same with noninfringing materials, equipment or devices, or modify same so it becomes noninfringing. The Contractor shall report to the Owner promptly and in reasonable written detail, each notice or claim of patent or copyright infringement based on the performance of this Contract of which the Contractor has knowledge. In the event of any claim or suit against the Owner on account of any alleged patent or copyright infringement arising out of the performance of this Contract or out of the use of any supplies furnished or work or services performed hereunder, the Contractor shall furnish to the Owner when requested by the Owner, all evidence and information in possession of the Contractor pertaining to such suit or claim. Such evidence and information shall be furnished at the expense of the Owner except where the Contractor has agreed to indemnify the Owner. This clause shall be included in all subcontracts.

ARTICLE 45 HISTORICAL, SCIENTIFIC AND ARCHAEOLOGICAL DISCOVERIES

45.1 All articles of historical, scientific or archaeological interest uncovered by the Contractor during progress of the Work shall be preserved in accordance with applicable law and reported immediately to the Project Manager. Further operations of the Contractor with respect to the find, including disposition of the articles, will be decided by the Owner in accordance with applicable law.

ARTICLE 46 SUBSTITUTIONS

46.1 Where reference is made to one or more proprietary products but restrictive descriptive material of only one manufacturer is used, it is understood that the products of other manufacturers will be accepted, provided they equal or exceed the standards set forth in the plans and specifications and are compatible with the intent and purpose of the design, subject to the written approval of the Owner and the Project Manager. If the descriptive material is not restrictive, the products of other manufacturers specified will be accepted without prior approval provided they are compatible with the intent and purpose of the design.

46.2 The Contractor may propose the substitutions of any material as a supplement to his bid with the monetary amount, additive or deductive as may be the case, clearly stated. Manufacturer's information, catalog numbers, and complete descriptive information shall be included with the proposed substitution. This shall be completely apart and separate from the base bid quotation and shall be solely for the information of the Owner, and the use of such proposed substitutions shall be strictly at the decision of the Owner. If substitution is accepted by the Owner, the Contract sum shall be adjusted from the base bid either up or down as indicated on the supplementary list.

ARTICLE 47 INSURANCE

47.1 General

47.1.1 The Contractor shall provide from insurance companies, acceptable to the Owner, the insurance coverage designated hereinafter and pay all costs. The Contractor also indemnifies the Owner as further described in Article 4.

47.1.2 Before commencing work under this Agreement, the Contractor shall furnish the Owner with certificates of insurance specified herein showing the type, amount, class of operations covered, effective dates, and date of expiration of policies. Furthermore, each such certificate shall contain a valid provision or endorsement that the policy may not be cancelled, terminated, changed or modified without first giving ten (10) days written notice to the Owner, which notice must be sent registered mail, return receipt requested, to the Project Manager.

47.1.3 In case of the breach of any provision of this Article, the Owner, at his option, may take out and maintain, at the expense of the Contractor, such insurance as the Owner may deem proper at the Contractor's expense and may deduct the cost of such insurance from any monies which may be due or become due the Contractor under this Agreement.

47.1.4 The Contractor shall either: (1) require each of his subcontractors to procure and maintain during the life of his subcontract, subcontractors' comprehensive General Liability, Automobile Liability and Property Damage Liability Insurance of the type and in the same amounts as specified in this subparagraph, or (2) insure the activity of his subcontractors in his own policy.

47.1.5 Co-Insurance: The Contractor herein agrees to name the Owner as an insured party on all liability insurance policies provided for by this Article 47, INSURANCE.

47.1.6 No insurance shall be cancelled or otherwise voided during the Contract period, without at least 10 days prior written notice to the Owner, nor shall any insurance be invalidated should the insured waive any or all right of recovery against any party.

47.1.7 Liability insurance may be arranged by Comprehensive General Liability and

Comprehensive Automobile Liability policies for the full limits required; or by a combination of underlying Comprehensive Liability policies for lesser limits with the remaining limits provided by an Excess or Umbrella Liability policy.

47.1.8 The Owner shall purchase and maintain such boiler and machinery insurance as may be required by the Contract Documents or by law. This insurance shall include the interest of the Owner, the Contractor, Subcontractors and Sub-subcontractors in the Work.

47.1.9 Any loss insured under Article 47 is to be adjusted with the Owner and made payable to the Owner as trustee for the insured, as their interests may appear, subject to the requirements of any applicable mortgage clause. The Contractor shall pay each subcontractor a just share of any insurance monies received by the Contractor, and by appropriate share of any insurance monies received by the Contractor, and by appropriate agreement, written where legally required for validity, shall require each subcontractor to make payments to his subcontractors in similar manner.

47.1.10 If the Contractor requests in writing that insurance for risks other than those described in this Article or other special hazards be included in the Owner's property insurance policy, the Owner shall, if possible, include such insurance, and the cost thereof shall be charged to the Contractor by appropriate Change Order.

47.1.11 The Owner as trustee shall have power to adjust and settle any loss with the insurers.

47.1.12 If the Owner finds it necessary to occupy or use a portion or portions of the Work prior to Substantial Completion thereof, such occupancy or use shall not commence prior to a time mutually agreed to by the Owner and Contractor and to which the insurance company or companies providing the property insurance have consented by endorsement to the policy or policies. This insurance shall not be cancelled or lapsed on account of such partial occupancy or use. Consent of the Contractor and of the insurance company or companies to such occupancy or use shall not be unreasonably withheld.

47.2 Workmen's Compensation and Employer's Liability Insurance:

47.2.1 The Contractor shall provide coverage and amounts as required by the Workmen's Compensation Act of the State of Colorado.

47.2.2 The Contractor shall provide Employer's Liability Insurance in an amount not less than \$100,000 for each occurrence.

47.2.3 The Contractor shall require any subcontractor to provide Workmen's Compensation and Employer's Liability Insurance in the same amounts for all of the subcontractor's employees to be engaged in work under this Agreement.

47.3 General Liability

47.3.1 General Liability Insurance shall be on a Comprehensive General Liability form and shall provide coverage for the following: Premises and Operations, Owners and Contractors Protective, Elevators, Independent Contractors, Products and Completed Operations, Contractual, Personal Injury, and Broad Form Property Damage; "XCU" exclusions must be deleted.

47.3.2 Minimum requirements for Comprehensive General Liability are: bodily injury, \$1,000,000.00 each person, \$2,000,000.00 each occurrence; property damage, \$1,000,000.00 each occurrence.

47.4 Automobile Liability

47.4.1 Comprehensive Automobile Liability Insurance shall include coverage for all owned motor vehicles and hired and non-owned motor vehicles.

47.4.2 Minimum requirements for Comprehensive Automobile Insurance are: bodily injury, \$1,000,000.00 each person, \$2,000,000.00 each occurrence; property damage, \$1,000,000.00 each occurrence.

47.5 Property Insurance:

47.5.1 The Owner may require the Contractor to purchase and maintain "Builder's Risk" Property Insurance for all work at the site to the full insurable value thereof. The Owner and the Project Manager shall be named as co-insured.

ARTICLE 48 UNCOVERING AND CORRECTION OF WORK

48.1 During construction, whenever materials requiring inspection in place by the Project Manager and the Owner to be permanently covered up, it shall be Contractor's responsibility to notify the Project Manager at least 24 hours in advance of commencement of such covering operation. In the event of failure by Contractor to give such notification, Contractor shall, at his own expense, uncover such portions of work as required by the Project Manager or the Owner, and reinstall such covering after satisfactory inspection and correction of any and all deficiencies.

ARTICLE 49 EQUAL OPPORTUNITY

49.1 The Contractor agrees to comply with the letter and spirit of the Colorado Antidiscrimination Act of 1957, as amended, and other applicable laws respecting discrimination and unfair employment practices (24-34-402, CRS 1973, as amended). The Contractor shall be responsible for any discriminatory or unfair employment practices of his subcontractors. Neither the Contractor nor any subcontractor will discriminate against any employee or applicant for employment because of race, creed, color, national origin, sex, religion, ancestry, mental or physical handicap, or age. Contractor shall take affirmative action to insure that applicants are employed, and that employees are treated during employment without regard to their race, creed, color, national

origin, sex, religion, ancestry, mental or physical handicap, or age. Such action shall include, but not be limited to the following: employment, upgrading, demotion, or transfer; recruitment, or recruitment advertising; layoff or termination; rates of pay or other forms of compensation; and selection for training, including apprenticeship. Contractor agrees to post in conspicuous places, available to employees and applicants for employment, notices setting forth the policies of non-discrimination.

49.2 Contractor and all subcontractors shall, in all solicitations or advertisement for employees placed by them or on their behalf, state that qualified applicants will receive consideration for employment without regard to race, creed, color, national origin, sex, religion, ancestry, mental or physical handicap, or age.

ARTICLE 50 CLAIMS

50.1 The Contractor shall not assert any claim arising out of any act or omission by any officer, agent or employee of the Owner in the execution or performance of this Contract against such officer, agent or employee in his or her individual or official capacities.

50.2 The Contractor shall require each Separate Contract Design Professional or Contractor to agree in his Contract not to make any claim against the Owner, its officers, agents or employees, by reason of such Contract with the contractor.

50.3 Nothing in this Contract shall be construed to give any person other than the Owner and the Contractor any legal or equitable right, remedy or claim under this Contract; and it shall be held to be for the sole and exclusive benefit of the Owner and the Contractor.

ARTICLE 51 NOTICES

51.1 Except as otherwise provided herein, any notice, approval, acceptance, request, bill, demand or statement hereunder from either party to the other shall be in writing and shall be deemed to have been given when either delivered personally or deposited in a U.S. mailbox in a postage prepaid envelope, addressed to the other party via certified mail. Notices to the Owner shall be addressed to the Project Manager by name. Either party may at any time change such address by delivering or mailing, as aforesaid, to the other party a notice stating the change and the changed address.

ARTICLE 52 LEGAL INSERTIONS, ERRORS, INCONSISTENCIES, OR DISCREPANCIES IN CONTRACT

52.1 It is the intent and understanding of the parties to this Contract that each and every provision of law required to be inserted in this Contract shall be and is inserted herein. Furthermore, it is hereby stipulated that every such provision is deemed to be inserted herein, and if through mistakes or otherwise, any such provision is not inserted in correct form, then this Contract shall upon application of either party, be amended by such insertion so as to comply strictly with the law and without prejudice to the right of either party.

52.2 If this Contract contains any errors, inconsistencies, ambiguities, or discrepancies, including typographical errors, the Contractor shall request a clarification of same by writing to the Project Manager whose decision shall be binding upon the parties.

ARTICLE 53 CAPTIONS OR HEAD NOTES

53.1 The captions or head notes on articles or sections of this Agreement, and marginal notes are intended for convenience and reference purposes only and in no way define, limit or describe the scope or intent hereof, or of this Agreement not in any way affect this Agreement.

ARTICLE 54 EFFECTIVE AND BINDING

54.1 This Contract shall not become effective or binding upon the Owner unless it has been authorized and executed in accordance with the ordinances of the City of Greeley.

ARTICLE 55 CONTRACTOR

55.1 All personnel assigned to the Project by the Contractor shall be required to cooperate fully with personnel of the Owner and if in the sole discretion of the Owner the Contractor's personnel fails so to cooperate, the Contractor shall relieve them of their duties on the Project when required by the Owner.

55.2 Within seven (7) consecutive calendar days after date of written notice to commence work, the Contractor shall designate in writing one person who, on his behalf, shall be responsible for coordinating all of the services to be rendered by the Contractor hereunder. Such designee shall be subject to the approval of the Owner. Any change to the approved designee shall be proposed in writing seven (7) days in advance and subject to Owner approval.

55.3 The Contractor shall engage, at his sole expense, all engineers, architects, cost estimators, lawyers, experts and Contractors as may be required for the proper performance of the Contract. The Contractor shall be responsible for the performance of the work of all architects, engineers, cost estimators, lawyers, experts and Contractors so engaged by him, including maintenance of schedules, correlation of their work and resolution of all difference between them. It is understood that all architects, engineers, cost estimators, lawyers, experts and Contractors are employees of the Contractor and not of the Owner, and the Contractor alone is responsible for their work.

55.4 All drawings, tracings, specifications, digital media/electronic files and other material prepared and furnished under and for this Contract shall become the property of the Owner upon substantial completion and/or their acceptance by the Owner and/or upon termination of the services

of the Contractor. Such documents shall be promptly delivered to the Owner upon demand and thereafter may be used by the Owner in whole or in part or in modified form, for those purposes it may deem advisable without further employment of, or payment of additional compensation to, the Contractor.

55.5 The Contractor shall not, without the prior written approval of the Owner, specify for the project, or necessarily imply the required use of any article, product, material, fixture or form of construction, the use of which is covered by a patent, or which is otherwise exclusively controlled by a particular firm or group of firms.

55.6 Should any claim be made or any action brought against the Owner relating to the design and satisfactory operation of the Project herein, the Contractor shall diligently render to the Owner without additional compensation any and all assistance which may be requested by the Owner.

55.7 The Owner's Project Manager's decision shall be final and binding upon the Contractor as to all matters arising in connection with or relating to this Contract. The Project Manager shall determine the amount, quality, acceptability and fitness of the work being performed hereunder and shall determine all matters relative to the fulfillment of this Contract on the part of the Contractor and such determination shall be final and binding on the Contractor. Acceptance by the Owner of any document hereunder and all supporting documents shall not relieve the Contractor of sole responsibility for work performed under this contract, including, but not limited to, the final design of the Project, including the plans, specifications and all supporting documents, except as to any feature thereof which the Owner had specifically directed in writing to be included over the written objection of the Contractor. In case any question shall arise, the decision of the Owner's Project Manager, who is hereby accepted by the Contractor as the arbiter, shall be a condition precedent to the right of the Contractor to receive any money under this Contract.

ARTICLE 56 APPEALS

56.1 Except as otherwise provided in this Contract, any dispute concerning a question of fact arising under this Contract which is not disposed of by Agreement shall be decided by the Project Manager, who shall reduce his decision to writing and mail or otherwise furnish a copy thereof to the Contractor. The decision of the Project Manager shall be final and conclusive unless, within fifteen (15) days from the date of receipt of such copy, the Contractor mails or otherwise furnishes to the Project Manager a written notice of appeal.

56.2 In the event a decision of the Project Manager is the subject of an appeal, such dispute may be settled by appropriate legal proceeding, or, if the parties mutually agree, through arbitration or administrative process. Pending any binding arbitative or administrative decision, appeal, or judgment referred to in this section or the settlement of any dispute arising under this Contract, the Contractor shall proceed diligently with the performance of this Contract.

56.3 Venue and jurisdiction of any suit, right, or cause of action arising under or in connection with this Contract shall lie exclusively in Weld County, Colorado.

**ARTICLE 57
PROHIBITED INTEREST**

57.1 No member, officer or employee of the City of Greeley shall have any financial or pecuniary interest, direct or indirect, in this Contract or the proceeds thereof.

**ARTICLE 58
FINDINGS CONFIDENTIAL**

58.1 Any reports, information, data, etc., available to or prepared or assembled by Contractor under this Contract shall not be made available to any individual or organization by Contractor without consent in writing from the Owner subject to applicable law.

**ARTICLE 59
GENERAL PROVISIONS**

59.1 Services and work performed by Contractor under this Contract shall conform to reasonable and normal professional standards known and accepted within the community.

59.2 No reports, graphics or other material produced directly or indirectly for the Owner under this Contract shall be the subject of an application for copyright or trademark by or on behalf of Contractor.

59.3 The laws of the State of Colorado and applicable Federal, state and local laws, regulations and guidelines shall govern hereunder.

59.4 The headings of the articles, clauses, and paragraphs of this Contract are inserted for reference purposes only and are not restrictive as to content.

59.5 This Contract and any subsequent amendment shall be deemed an original having identical legal effect, and all of which together constitute one and the same instrument.

59.6 Nothing contained herein shall be deemed to give any third party any claim or right of action against the Owner which does not otherwise exist without regard to this Contract.

59.7 Where a number of days is specified in this Contract it shall mean calendar days unless otherwise specified.

59.8 This Contract shall not be assigned, in whole or in part, without the written consent of the Project Manager and Contractor.

59.9 The Owner certifies the following;
A. An amount of money equal to or greater than the Contract amount has

been appropriated and budgeted for the Project which this Contract concerns.

B. No Change Order which requires additional compensable work to be performed by the Contractor will be issued by the Owner unless an amount of money has been appropriated and budgeted sufficient to compensate the Contractor for such additional compensable work unless such work is covered under the remedy-granting provisions of this Contract.

C. As used in this paragraph, "remedy granting provision" shall mean any clause of this Contract which permits additional compensation in the event of a specific contingency or event occurs. This term shall include, but not be limited to, change clauses, differing site conditions clauses, variation in quantities clauses, and termination for convenience clauses.

ARTICLE 60 CONTRACTOR ACCEPTANCE

60.1 The acceptance by the Contractor, his successors or assigns of any payment made on the final acceptance of the Project under this Contract or of any final payment due on termination of this Contract, shall constitute a full and complete release of the Owner from any and all claims, demands and causes of action whatsoever which the Contractor, his successors or assigns have or may have against the Owner under the provisions of this Contract.

60.2 No action shall be maintained by the Contractor, its successors or assigns, against the Owner on any claims based upon or arising out of this Contract or out of anything done in connection with this Contract unless such action shall be commenced within 180 days after the date of filing of the voucher for final payment hereunder in the office of the Finance Director, or within 180 days of the termination of this Contract.

ARTICLE 61 SUCCESSORS AND ASSIGNS

61.1 The Contractor binds itself, its partners, successors, assigns and legal representatives to the other party to this Contract and to the partners, successors, assigns and legal representatives of such other party with respect of all covenants of this Agreement. The Contractor shall not transfer, assign, or subcontract any interest in this Agreement.

ARTICLE 62 SEVERABILITY CLAUSE

62.1 If any provision of this Agreement is subsequently declared by legislative or judicial authority to be unlawful, unenforceable, or not in accordance with applicable laws, statutes, and regulations of the United States of America and the State of Colorado, all other provisions of this Agreement shall remain in full force and effect.

ARTICLE 63 AGREEMENT

63.1 This Agreement represents the entire and integrated Agreement between the Owner and the Contractor and supersedes all prior negotiations, representations or agreements, either written or oral. This Agreement may be amended only by written instrument signed by both Owner and Contractor.

**ARTICLE 64
COLORADO LABOR**

64.1 In accordance with C.R.S. §8-17-101, all parties contracting with the City of Greeley on public works projects shall employ Colorado labor to perform the work to the extent of not less than eighty percent (80%) of each type or class of labor in the several classifications of skilled and common labor employed on this project.

**ARTICLE 65
ELECTRONIC SIGNATURE**

65.1 The Contract Documents may be executed in two or more counterparts, each of which shall be deemed an original but all of which together shall constitute one and the same document. The Contract Documents, including all component parts set forth above, may be executed and delivered by electronic signature by any of the parties and all parties consent to the use of electronic signatures.

**ARTICLE 66
FORCE MAJEURE**

66.1 To the extent that either party is not able to perform an obligation under this Agreement due to fire; flood; acts of God; severe weather conditions; strikes or labor disputes; war or other violence; acts of terrorism; plague, epidemic, pandemic, outbreaks of infectious disease or any other public health crisis, including quarantine or other employee restrictions; act of authority whether lawful or unlawful, compliance with any law or governmental order, rule, regulation or direction, curfew restriction, or other cause beyond that Party's reasonable control, that Party may be excused from such performance so long as such Party provides the other Party with prompt written notice describing the condition and takes all reasonable steps to avoid or remove such causes of nonperformance and immediately continues performance whenever and to the extent such causes are removed.



SECTION 00520
SUBCONTRACTORS/MATERIALS SUPPLIERS AND RELATED DATA

Firm Name: _____ City Contractors License # _____

Primary Contractor _____

PROJECT: _____ Address: _____

For each Subcontractor and/or Materials Suppliers to be utilized, please provide the following information (use additional sheets as necessary):

Phone Number: _____ Fax Number: _____

Proposed work and percentage of total work to be assigned _____
Percentage: _____ %

Firm Name: _____ City Contractors License # _____

Address: _____

Phone Number: _____ Fax Number: _____

Proposed work and percentage of total work to be assigned _____
Percentage: _____ %

Firm Name: _____ City Contractors License # _____

Address: _____

Phone Number: _____ Fax Number: _____

Proposed work and percentage of total work to be assigned _____
Percentage: _____ %

Firm Name: _____ City Contractors License # _____

Address: _____

Phone Number: _____ Fax Number: _____

Proposed work and percentage of total work to be assigned _____
Percentage: _____ %

Firm Name: _____ City Contractors License # _____

Address: _____

Phone Number: _____ Fax Number: _____

Proposed work and percentage of total work to be assigned _____
Percentage: _____ %

If the Primary Contractor adds any Subcontractors or Materials Suppliers during the duration of the project, the Primary Contractor will supply the City with an updated form before the Subcontractor or Materials Supplier will be allowed to work on the project.

SECTION 00620 - SPECIAL PROVISIONS

2021 Infrastructure Improvement Program

SCOPE OF WORK

The work in this contract will consist of furnishing all labor, equipment, and materials for the replacement or construction of designated concrete curbs, gutters, pavements, concrete driveways, sidewalks, handicap ramps, minor landscaping work, possible reconstruction of inlet tops and other related and incidental work required to complete the project.

At least 60% of the work must be performed using the Contractor's own personnel.

1. **NOTICE TO BIDDERS:** There is a set amount of funding available for construction. Due to budgetary constraints, the current Scope of Work, as reflected in the Bid Schedule quantities, may be increased or decreased as necessary or allowed to meet the budget goals. **Retainage for this project is set at 10%.**
2. **PROJECT DESCRIPTION – The 2021 City of Greeley Infrastructure Improvement Program** Notice To Proceed will be issued on or about **August 12, 2021**. Work in general consists of: significant landscaping, removal and replacement of an estimated 3,400 linear feet of curb and gutter and approximately 1,200 square yards of concrete including sidewalks, access ramps, cross pans, alley aprons, etc between 21st and 23rd Avenues and between 10th Street and 11th Street and on 22nd Avenue between 11th St and 13th Street. This project is located in Central Greeley within the Maplewood Subdivision. **The contractor shall adhere to all traffic control and erosion control standards including submission of documents, reporting and maintenance for all locations. All locations may be subject to change by the City of Greeley's designated representatives (as noted in this document).**

Please note that the estimated quantities in "Section 00130 – Bid Schedule" are only estimates, the total meant to correspond with Owner's construction budget. Actual work scope quantities will be dependent on the successful Bidder's unit bid prices.

1. **GOVERNING SPECIFICATIONS** – The following manuals are made part of these specifications:
 - 1) The City of Greeley Public Works Design Criteria and Construction Specifications Manual (DCCSM), Volume 1 "Streets", latest edition. A copy of the specifications manual can be obtained from the City of Greeley Public Works Department located at 1001 9th Avenue.
 - 2) The Colorado Division of Transportation (CDOT) Standard Specifications for Road and Bridge Construction, the CDOT M & S Standards, CDOT Construction Manual, and CDOT Materials Manual latest editions.

In case of conflict, documents shall have the following priorities: (1) Special Provisions, (2) General Conditions, (3) DCCSM, and (4) CDOT Standard Specifications.

ALL CONSTRUCTION WILL MEET THE AMERICANS WITH DISABILITIES ACT (ADA) CONSTRUCTION SPECIFICATIONS (LATEST EDITION).

2. **UTILITY LOCATES** – The City will not be responsible for any construction down time due to failure on the Contractor’s part to NOTIFY utility companies of conflicts. The Contractor will contact the utility companies before construction. Call Utility Notification Center of Colorado for utility locates (ph. 811). No work will be allowed to be performed until Contractor calls for and receives utility locates.
3. **CONTRACT TIME & SCHEDULING** – CONTRACT TIME for this project will be **90 calendar days**. **Calendar Days** is defined as each and every day shown on the calendar, including weekends and holidays. It is anticipated that the Notice to Proceed will be issued on or about August 12, 2021.

Approximately 7-14 calendar days before construction commences, the Contractor will be provided with an initial list of work locations. The City reserves the right to prioritize work locations. The Contractor shall provide a complete SCHEDULE for the initial construction projects within 72 hours.

Schedule changes shall be provided to the Construction Inspector each Monday by 10:00 a.m. Updates and changes shall be distinguished from previous schedules.

Throughout the duration of the Contract, the City will provide the Contractor with additional project locations if there are any. These additional locations shall be provided to the contractor on a periodic basis. The City will make an effort to collect multiple work sites before submittal to the contractor. The Contractor shall provide a SCHEDULE for each successive list within 48 hours of receiving said list.

Every effort shall be made by the Contractor to complete the project within the “Contract Time.” The “Contract Time” anticipates “Normal” weather and climate. The Contractor’s schedule must anticipate normal adverse weather delays on all weather dependent activities. For additional information regarding adverse weather see Article 32, “Extension of Time” in the General Conditions.

All streets will remain open to traffic. The Contractor must allow for this when scheduling his work. The Contractor is limited to working normal business days/ hours, 7:00 a.m. to 5:00 p.m. Work hours may be restricted depending on the location of the work, such as in a school zone or on a heavily trafficked arterial street. If the Contractor chooses to work outside normal business days/hours, a request must be made to the City 48 hours prior. If the request is approved, there will be a deduction from the final pay estimate to cover inspection costs. For one Construction Inspector working overtime on a job, the Contractor will be charged \$75.00/hr. This deduction may be waived partially or in its entirety, at the discretion of the City, based on unusual or special circumstances.

4. **PRE-CONSTRUCTION MEETING** – The date for the pre-construction meeting will be announced after the bids are opened and the contract has been awarded. The Contractor will be expected to present to the City of Greeley the following items at the pre-construction meeting:

- 1) Traffic Control Plan
- 2) “Rough” Schedule
- 3) Concrete Mix Designs
- 4) Material Suppliers’ List
- 5) Subcontractor List

- 6) Copy of Flagger Certifications
- 7) Copy of the Traffic Control Supervisor's Certification

The Contractor's Crew Supervisor is **required** to attend the pre-construction meeting. Crew Supervisor is described as that individual who will directly supervise the on-site demolition/construction crew members.

The Contractor is required to obtain a local telephone number before commencement of work and maintain the telephone number until completion of the contract. This telephone number and a contact name could be printed on all notification pamphlets. Do not place pamphlets in mailboxes. **It is a federal offense for anyone other than a postal employee to put mail in mailboxes!**

5. **PERMITS** – The Contractor must obtain all necessary permits for the work. Fees will be waived for City permits.
6. **EMERGENCY AGENCY NOTIFICATIONS** – The Contractor will be responsible for **notifying** all emergency agencies (350-9600) when and where work will be done in the public rights-of-way of major collector or any arterial streets/avenues. The Contractor will be responsible for giving all emergency agencies a telephone number where they can be reached. The Contractor will also be responsible for notifying Greeley-Evans Transit whenever they are working near a bus stop. Contact GET Services (350-9290).
7. **CREW SUPERVISOR** – The Contractor's Crew Supervisor designated at the pre-construction meeting shall be within a reasonable travel distance to all work sites during construction. Due to the nature of this program, a number of sites may have activity at any one time. At all times, the Crew Supervisor, or a designee appointed to make final decisions on behalf of the contractor, shall be available within 30 minutes to any active construction site. Because the City contact is English speaking, the Crew Supervisor, or the appointed designee, must be capable of communicating with the City contact in English.
8. **PROJECT MEETINGS** – Frequency and location of project meetings will be determined at the Pre-Construction meeting.
9. **TRAFFIC CONTROL** – The Contractor will comply with the requirements of Section 01010, Paragraph 1.3.G of the Streets Design Criteria and Construction Specifications (DCCSM). The Contractor will not do any construction work in the public right-of-way prior to the City's review and acceptance of the Traffic Control Plan. The **Traffic Control Plan** will include the City's Traffic Control Plan Review form.

The Contractor shall designate an individual, other than the Crew Supervisor, to be the Traffic Control Supervisor (TCS). The TCS will not be required to be on site, **except during job setup**, but must be available twenty-four (24) hours a day. The name and phone number of the TCS will be provided to the City at the Pre-Construction meeting. The Contractor will also provide the name and phone number of an alternate local traffic control company that will act on the Contractor's behalf in case the designated TCS cannot be reached. **Alternatively**, the City or its subcontractor may perform traffic control services, at cost to the Contractor, if Contractor is unresponsive or otherwise is deemed to not be performing traffic control duties in accordance with the submitted plan.

The Contractor will be notified when the traffic control for any work site is observed to be in

an unacceptable condition. The Contractor will not be allowed to continue work at that location until the problems are corrected. *Failure to correct the traffic control deficiencies prior to continuance of the work will result in non-payment for the work performed at the locations in question.*

Traffic Control will be paid for as part of the unit price for the various concrete work and will not be paid for separately except where itemized in Section 130 – Bid Schedule (“Certified Flagger”& “Arrow Board”). Payment for these two items will be made only when their need is indicated on the approved Traffic Control Plans, their use is required by the MUTCD, or when/where otherwise requested or directed by the City.

This information is not guaranteed to be final, complete or all-inclusive, and is provided only as an aid to assist Bidders in preparing their Bids.

The Contractor shall be solely and completely responsible for the conditions at and adjacent to the job site, including the safety of all persons and property during the performance of the work. This requirement shall apply continuously and shall not be limited to normal working hours. The duty of the City to conduct construction review of the Contractor’s performance is not intended to include review of the adequacy of the Contractor’s safety measures in, on, or near the construction site.

The Contractor shall provide all lights, signs, barricades, flag persons, TCS or other devices necessary to provide for public and worker safety in accordance with the current Manual of Uniform Traffic Control Devices, and the City of Greeley supplement thereto.

10. **EQUIPMENT STAGING/PARKING** – With site specific approval from the City, there is the potential that contractor’s vehicles, trailers, large equipment and supplies potentially can be parked along the curbs in public rights-of-way. Should a resident complain about the equipment location, the Contractor shall move those items to another location. All items left overnight shall have appropriate traffic control devices set up. The Contractor shall not park on any private property without permission from the property owner.
11. **CONSTRUCTION** – Subgrade shall be accepted by the City prior to placement of any concrete.

The Contractor must possess and use a stamp that includes the Contractors name and the year in which the work is being done. The stamp will be used to stamp the concrete to permanently identify the Contractor that performed the concrete work. Locations will be as directed by the City. The Contractor will not be allowed to place concrete until the City has approved the stamp for use.

The Contractor will cleanly remove only enough existing asphalt to allow for installation of formwork. Contractor will be careful that subgrade exposed by excavations or removals does not become saturated or overly wet. Any subgrade materials that become unstable or are unable to obtain proper compaction due to the entry of excessive moisture must be excavated, replaced with suitable material, and approved by the City. Additionally, removal of existing work may be required to ensure all damaged subgrade is removed and replaced. No additional payment will be made for this work.

Hot-mix asphalt shall be used to fill the void remaining after removal of formwork until a permanent Asphalt Patch is placed by others.

All concrete edges will be formed unless allowed or directed otherwise by the City. The new work will be cured and protected by the Contractor from bikes, dogs, foot traffic, vandalism, etc. until the concrete has reached a stage where it cannot be defaced or marred. New work left unattended and disfigured or defaced may be cause for the work to be rejected at the discretion of the City and replaced at Contractor's expense.

The City of Greeley strongly recommends the use of an approved concrete sealer, even when not required by City Standards, to protect the Contractor's work which will be exposed to salts, chemicals, or other elements. The City's approval of a particular sealer does not relieve the Contractor of any Warranty responsibilities (see below). Areas where the existing concrete has heaved or where, in the opinion of the City, newly placed concrete has the potential to heave, shall receive special sub-base treatment. These areas will be over excavated a minimum of 8 inches and the void filled with an approved Compacted Stabilization Material; such as, Cl. 6 ABC, recycled crushed concrete or MGPEC Road Base, as directed by the City. The over excavation will be included in the cost of the concrete work unless the excavation exceeds one foot.

The Contractor will protect the asphalt (both existing and new) from solvents and oils. Equipment leaking any fluid will be removed from the work site immediately and may not be returned to the work site until all leaks are repaired. If any piece of equipment leaks fluid a second time, it will be removed from the work site immediately and will not be allowed on the work site again for the remainder of the project.

Barricades and signage shall remain in place during the course of the work or until concrete reaches 80% of design strength. Contractor is to provide 48-hours notice to the City of when barricades and signage are expected to be removed.

Each work site will be cleaned and have traffic control removed within seven days of final concrete placement. Forms will be removed, concrete debris will be picked up, the work area will be swept, sprinklers will be raised, lowered, adjusted, replaced and/or repaired, voids will be filled with suitable topsoil material and/or sodded, and all other work related to cleanup, irrigation, and landscape repair will be completed to the satisfaction of the City. The Contractor's topsoil material shall be visually inspected by the City prior to use.

12. **CONSTRUCTION STAKING** – The City of Greeley's Capital Improvement Division Surveying staff will provide initial construction staking of improvements when requested, or at the request of the City's designated Construction Inspector. A minimum of 14 days' notice must be given to the Inspector by the Contractor in order to utilize this service. Replacement of stakes lost or destroyed by the Contractor will be the Contractor's responsibility. The City's surveying staff will replace lost or destroyed stakes at the rate of \$110 per hour at the request of the Contractor. A minimum of one (1) hour will be charged to the contractor for each request.

13. **VEHICULAR ACCESS** – Driveways and other vehicular access points will be closed for a minimum amount of time, but shall in no case be closed longer than seven calendar days without the approval of the City. The Contractor will coordinate commercial driveway and major access closures (such as multiple family entrances) with property owners one week prior to construction by written notification, with final approval by the City. If directed by the City, individual driveways and other concrete may be required to be open within 24 hours of placement. At such locations, an appropriate High Early Strength (HES) concrete mix

may be required. When used at the direction of the City, HES concrete will be paid for at the Unit Bid Price.

14. **PERMANENT STREET SIGNAGE** – Permanent street signage work will be done by the City of Greeley at no cost to the Contractor. Removal of all signs will be coordinated with the City. The Contractor shall not remove any City signs. It shall be the responsibility of the Contractor to notify the City Traffic Division at 350-9355 when street and traffic signs are ready to be permanently re-set (48 hours prior to removal of traffic control devices). Prior to any removals, Contractor is to note and document any pavement and curb markings that may be removed or obliterated by construction activities.
15. **MATERIALS ACCEPTANCE & QUALITY CONTROL TESTING** – All concrete shall meet MGPEC Construction Specifications Items 11.2 and 11.8 (30.2), unless otherwise approved by the City.

The City will provide quality control and quality assurance sampling and testing to the extent the City deems necessary for project acceptance. The Contractor shall coordinate with the City as to when the work is ready for testing. The Contractor shall assist the City in obtaining samples for testing. The Contractor shall uncover and recover at no cost to the City any work completed prior to testing and allow the City to test. The Contractor shall be responsible for costs associated with re-testing materials that fail tests.

16. **GRADING** – Costs associated with **Unclassified Excavation** will be included in the unit price of the concrete work and will not be paid for separately. The exception to this would be if an area requires excavations greater than one foot to encounter acceptable subgrade material. Payment for the excavation over one foot will be paid for at the Unit Bid Price. **Compacted Stabilization Material** to replace Unclassified Excavation greater than one foot deep will be paid for at the Unit Bid Price.
17. **EROSION CONTROL & PROTECTION OF STORM DRAINS** – Contractor is responsible for control and routing of storm water runoff draining around and from the construction area to prevent erosion, sedimentation or other damage to storm drain systems. The requirements of saw-cutting and concrete placement are provided in the Storm Drain Management Division Best Practices document attached herein.
18. **WORK ADJUSTMENTS** – The City reserves the right to prioritize construction at specific locations in the City. The City reserves the right to add, delete, and/or substitute other construction to this project. Quantities may be added or deleted and adjustments will be made to the contract price according to the contract unit prices provided on The Contractors Schedule. Sizeable adjustments in overall contract scope may result in a corresponding adjustment to the contract time.

19. **BID ITEM DESCRIPTIONS**

Item No. Description

- 1) **Remove Curb and Gutter (0 to 2' pan)** – This item includes Vertical-Face Curb and Gutter (Detail S-16); Median Curb and Gutter (Detail S-18); 6" Vertical-Face Barrier Curb (Detail S-18); Drive-Over Curb and Gutter (Detail S-15A); and includes sections with high-back curb and occasionally typical curb and gutter sections. Any

excess width of pans over two-foot (2') wide will be paid for as denoted in Item No. 2. Paid per linear foot (LF).

- 2) **Remove Concrete Flatwork (Thickness Varies)** – Includes all concrete sidewalks, driveways, alley aprons, access ramps, cross pans, aprons, and concrete pavements and any portion of a gutter pan in excess of the typical two-foot (2') wide gutter pan normally associated with “curb and gutter.”
- 3) **Removal of Rollover C&G/Sidewalk**– Includes any type of drive-over curb, gutter, and sidewalk regardless of width. Payment is based upon linear distances running parallel to the flowline at the mid-point in the width.
- 4) **Remove Asphalt (Thickness Varies)** - Includes the removal of existing asphalt walk-path or removal of asphalt to accommodate for larger area of concrete placement. Removal of asphalt for concrete forms will not be paid for with this item.
- 5) **Sawcut Joint** – Sawcut shall be paid by the linear foot (LF) and only at the City’s request in lieu of tooled joints
- 6) **Concrete Sawcut Demo** – Sawcut shall be paid by the linear foot (LF) and only in those areas not being removed at an existing joint.
- 7) **New C&G 0-2' Pan (i.e. Vertical Curb and Gutter: Sim to S-16)** – This item shall be paid for in linear feet (LF) and shall encompass any curb up to 6” in height and up to a gutter width of 2 feet. See Standard Detail Nos. S-16, S-18 and S-15A.
- 8) **New High Back Curb and Gutter (8" and above)** – This item shall be paid for in linear feet (LF) and shall encompass any curb with a height over 8”. See Standard Detail Nos. S-16 and S-18.
- 9) **24 Hr. High Early Mix – Up Charge** – If directed by the City, individual driveways and other concrete may be required to be open within 24 hours of placement. At such locations, an appropriate High-Early Strength (HES) concrete mix may be required. When used at the direction of the City, HES concrete will be paid for in cubic yards (CY). Written permission from the Construction Inspector or the Project Manager is required prior to installation.
- 10) **New Rollover C&G and SW**– See Standard Detail No. S-15. The width shall vary depending on the location, but in most cases shall match existing. Item shall be paid for as linear feet (LF) and based upon distances running parallel to the flowline at the mid-point in the width.
- 11) **New 4" Concrete** – In general this thickness shall include items such as sidewalks, (those similar to, but not limited to, Standard Details S-16 and S-21). Payment is in square yards (SY).
- 12) **New 6" Concrete** – In general this thickness shall include items such as sidewalks (where vehicular traffic is possible), residential driveway aprons, curb ramps, concrete paving, etc., (those similar to, but not limited to, Standard Details S-11, S-12, S-12-4, S-13, S-14, S-16, S-21, S-26, S-27, and S-29). Paid by square yards (SY).

- 13) **New 8” Concrete** – In general this thickness shall include items such as sidewalks (where vehicular traffic such as trash trucks is possible), cross pans, commercial driveway aprons, concrete paving, etc., (those similar to, but not limited to, Standard Details S-11, S-12, S-12-4, S-16, S-21, S-26, S-27, S-28 and S-29). Paid per square yard (SY).
- 14) **New 5" Concrete w/ Fiber Reinforcement** – Concrete shall be reinforced with Buckeye UltraFiber 500 Fiber or equal and shall be used at a rate of 1.5 lbs per cubic yard of concrete or as specified by the manufacturer. In general this item shall include items such as bike path or walk path, (those similar to, but not limited to, Standard Details S- 29). This item will be placed by buggy. Paid per square yard (SY).
- 15) **Unclassified Excavation (greater than 1 ft.)** – Costs associated with this bid item will be included in the unit price of the concrete work and will not be paid for separately. The exception to this would be if an area requires excavations greater than one foot (1 ft.) to encounter acceptable subgrade material. At that point the over-excavation would be paid for in cubic yards (CY).
- 16) **Compacted Stabilization Subgrade Import (6" Base)** – Materials shall conform to the City of Greeley’s Construction Specifications, Streets, Section 02229, Aggregate Base Course. Where possible we would recommend the usage of recycled crushed concrete. Contractor shall submit delivery slips to the City for reimbursement of this bid item. This bid item shall be paid for in ton units.
- 17) **Major Re-landscaping (Sprinklers, etc.)** – Includes final grading or laying back of adjacent existing grades or other such re-shaping of an area to blend to and match the grade of the new Work. For grading to be considered for payment under this bid item, the extent of the re-grading must be such that equipment or machinery is required to perform the work.

Sprinkler System Repair includes the lengthening or shortening of line over five feet, installation of new heads (does not include replacement of heads damaged by Contractor), and removal and replacement of large sections of a system. For work to be paid for under this bid item, the City must authorize all work to Sprinkler System Repairs prior to making adjustments. Payment for Sprinkler System Repair will be paid for by the hour and includes all material, labor, and equipment costs. Minor sprinkler adjustments will be included in the cost of the concrete and will include shortening of lines, or lengthening the lines five feet or less, and raising or lowering sprinkler heads. Breakage by the Contractor to existing sprinkler heads or lines shall be repaired by the Contractor at no cost to the City or the property owner. Contractor is to notify the property owner 72 hours in advance when sprinkler adjustments, repairs, or replacements are scheduled. All sprinkler work is to be tested with the property owner present. The Owner may waive this requirement if unwilling or unable to be present. Contractor shall obtain this waiver in written form from the Owner. Paid per hour of labor (HR).

- 18) **Reconstruct Inlet Top (up to 2' below grade)** – At the direction of the City, inlet tops and up to 24 inches of vertical inlet walls will be removed and reconstructed. New grates and frames per the detail will be required unless determined by the City that existing hardware may be re-used. An alternate grate and frame combo other than that specified may be considered for substitution by the City. Written approval

from the City is required. The contractor shall attempt to retain any existing rebar within the walls being demolished. If no or insufficient rebar exists, the contractor shall drill (4" min.) and epoxy #4 rebar vertically into the remaining portion of the walls and/or base slab every 8" on center. Rebar shall extend to within 3" of the top of walls. Horizontal #4 rebar shall be tied horizontally to the verticals, continuous around corners utilizing hooks or corner bars. See detail attached to these Special Provisions.

- 19) **Adjust Meter Pit** – Adjust up or down to finish grade. Paid per meter pit adjustment (EA).
- 20) **Landscape Curb 0" – 6"** – Per the detail attached to these Special Provisions. To be used only where directed in lieu of grading out finish grade to match new construction. Paid per linear foot (LF).
- 21) **Landscape Curb 7" – 18"** – Per the attached detail to these Special Provisions. To be used only where directed in lieu of grading out finish grade to match new construction. Paid per linear foot (LF).
- 22) **Landscape Curb 19" – 48"** – Per the attached detail to these Special Provisions. To be used only where directed in lieu of grading out finished grade to Match new construction. Paid per linear foot (LF).
- 23) **ADA Detectable Warning plates/domes** – shall be ADA compliant. The plates are to provide integral lugs or anchors such that anchorage is provided to mechanically secure the plates into the concrete. The plates are to be approved by the City prior to use. Detectable Warning Plates will be paid for by the square foot (SF). Detectable Warning Plates will be paid for in addition to the concrete into which they are set.
- 24) **Chase Drain (12" Max Opening)** – This bid item shall conform to Standard Detail S-23. Paid for per square foot of steel plate (SF). Should the sidewalk be detached from the curb as in Detail S-23-D, the concrete channel from the sidewalk to the street will be paid for as vertical Curb and Gutter.
- 25) **Remove and Reset Mailbox** – Per the detail attached to these Special Provisions. For bidding purposes, assume reuse of the existing posts and boxes. If directed by the City, provide new post and/or box. Payment for new materials will be cost plus 20%. Material costs plus 20% will be paid in addition to the unit bid price for "Remove and Reset Mailbox".
- 26) **Tree and Root Pruning** – The Contractor must engage the services of a licensed arborist, as licensed by the City of Greeley Forestry Division, for all tree root pruning of roots larger than two inches in diameter. If the Contractor can satisfy the requirements of the City Forester by performing the work with Contractor's own personnel, the services of a licensed arborist may not be necessary. Root pruning only applies to live trees. Any other root removal shall be designated as incidental to subgrade preparation. This item shall be paid by the hour (HR).
- 27) **Saw-Cut to Preserve Asphalt** – Where allowed and directed by the City when concrete abutting asphalt is required to be removed. Provide a clear full depth saw-

cut at the existing asphalt/concrete interface to aid in a clean separation. Paid per linear foot (LF).

- 28) **Colored Concrete (4 LB Max.) (Add On)**– Add-on cost per cubic yard (CY) of any thickness of concrete (based on 4 sack color).
 - 29) **Stamped Concrete (Add On)** – Add-on cost per square yard (SY) to any thickness of concrete (based on staggered brick pattern).
 - 30) **Portable Sanitary Station(s)** – Number and locations to be determined by Contractor based on number of simultaneous work sites and number of workers. Bid Price is lump sum (LS) for this single item, regardless of number of stations required and provided. Must be onsite 95% of the project duration.
 - 31) **4” PVC Installed Under Sidewalk** – At the discretion of the city inspector, the contractor will install PVC sleeves for sprinkler line tie-ins under the Work. Paid per linear foot (LF).
 - 32) **Remove 6” CMP (19th Ave & 25th St)** – Remove 6” corrugated metal pipe 0-2 foot depth.
 - 33) **Arrow Board** – When shown on the approved Traffic control plans, or otherwise required, or when requested at the inspector’s discretion, a daily rate (DAY) will be paid.
 - 34) **Certified Flagger (When Directed By City)** – When shown on the approved Traffic control plans, or otherwise required, or when requested at the inspector’s discretion, an hourly rate (HR) will be paid.
 - 35) **Quality Control – Standard Proctor** – The test shall be all inclusive using AASHTO T99. Paid per proctor (EA).
 - 36) **Quality Control – Soils Compaction** – Embankment and subgrade soils compaction; % moisture and % compaction. Paid per scheduled visit of materials tester (EA).
 - 37) **Quality Control – Concrete Test & Break Results** – Concrete Sampling and Testing; Includes at a minimum temperature, slump, air and compressive strength (includes up to four cylinder breaks each). Paid per set of above mentioned tests and break results (EA).
- 20. PAYMENT** – Actual payments will be based upon mutually accepted As-Built quantities. The As-Built quantities will be determined in the field with measurements jointly collected by the Construction Inspector and the Contractor’s Representative. No payment will be made on work sites that have not been completed, including clean up. Request for Payments shall be made at least monthly unless approved otherwise by the Project Manager.

21. NOTIFICATION

The Contractor is required to post on all properties adjacent any to construction site a notification pamphlet 72 hours prior to commencement of work at that site. An exception to

this is in the case of complete driveway or entrance closures. In these cases, notification to the affected property owners or businesses must be delivered a minimum of one week prior to the closure. The pamphlet will be provided to the Contractor by the City. The pamphlets will only be delivered between the hours of 8:00 a.m. and 6:00 p.m. When delivering the pamphlets, the Contractor shall contact the resident or business to advise them what will be happening at their property. When businesses are affected, Contractor is to hand-deliver the notification pamphlet to either the business *owner*, or some other employee *in responsible charge* of the business. If there is a subsequent delay to the scheduled work time due to poor weather, equipment breakdowns, and/or other causes, the Contractor will post at the affected properties a revised notice informing property owners of the delay with an updated construction schedule.

Do not place pamphlets in mailboxes. **It is a federal offense for anyone other than a postal employee to put mail in mailboxes!**

22. **WARRANTY** – Contractor is responsible for providing a **TWO-YEAR** warranty to the City of Greeley for all work completed under this contract. The City will establish the beginning of the TWO-YEAR warranty period with the issuance of the Certificate of Final Acceptance. If the concrete fails, spalls, or deteriorates during the first or second year, the concrete will be replaced under this warranty. Warranty work will be completed according to these contract specifications and within 30 days of written notification by the City of Greeley. See Article 11, “Warranty of Work” in the General Conditions for additional information. **The City of Greeley no longer waives permit fees for warranty work.**

23. **ATTACHED DOCUMENTS** – The following documents shall be a part of the Special Provisions:

- Stormwater Management Division Requirements – 1 page
- Street, Curb, and Gutter Replacement and Construction – 1 page
- COVID-19 Multi-Industry Construction Guidance – 3 pages
- Landscape Curb detail – 1 page
- Adjust Inlet Detail – 1 page
- Remove & Reset Mailbox Detail – 1 page
- Sidewalk Chase Drain Detail – 2 pages



**DEPARTMENT OF PUBLIC WORKS
STORMWATER MANAGEMENT DIVISION
REQUIREMENTS: MANDATORY AS INDICATED BELOW**

Activities such as asphalt application, slurry saw cutting, and directional boring can contribute high concentrations of toxic hydrocarbons, other toxic organic compounds, oils and greases, solids, and heavy metals to stormwater runoff. Concrete pouring can contribute suspended solids and heavy metals to stormwater runoff and cause pH increases in receiving waters.

The following Best Management Practices, (BMP's), or equivalent measures, methods, or practices are required if you are engaged in saw cutting, concrete pouring or asphalt application in right-of-ways within the City Of Greeley.

Slurry from Sawcutting:

Storm drains can carry saw cutting slurry and other pollutants from the streets and gutters directly to local waterways. This slurry can be toxic to fish and wildlife. The slurry can clog storm drains and catch basins which increase maintenance costs and could cause flooding.

If saw cut slurry from your job runs down the gutter uncontained, you have violated City Code. This also is a violation of state and federal regulations. Offenders may be subject to fines and clean up costs.

Concrete Pouring and Asphalt Applications EFFECTIVE IMMEDIATELY	Saw Cut Slurry And Directional Boring Mud
<p>1. Use drip pans, ground cloths, and perhaps heavy plywood whenever concrete, asphalt, and asphalt emulsion chunks and drips are likely to fall unintentionally, such as beneath exit points from mixing equipment.</p> <p>2. Place storm drain barriers or similarly effective containment devices over all nearby drains at the beginning of the work day. All accumulations of runoff, aggregate chunks, and other solids must be collected with a shovel or other mechanism for proper disposal at the end of the work day (or more frequently) prior to removing the containment device(s). Drain barriers and other containment devices are commercially available.</p> <p>3. Contain and collect the slurry from exposed aggregate washing, where the top layer of unhardened concrete is hosed or scraped off to leave a rough finish. Use a storm drain barrier or other containment device, as mentioned above. All collected runoff must be properly disposed.</p> <p>4. Concrete and concrete pumping vehicles shall not, under any circumstances, discharge any concrete, slurry, or rinse water into street gutters, storm drains or drainage ditches, and detention ponds. GREELEY CODE 14.16.170</p> <p>Designate a wash-out area on-site where cleaning of application and mixing equipment can take place and where the rinse water is controlled. It is also acceptable to dispose of rinse water and slurry in a hole in the ground big enough to contain the slurry and rinse material. Commercial products and services are also available for concrete, slurry, and rinse water disposal.</p> <p>Routine Maintenance: Sweep the pouring area at the end of each day to collect loose aggregate chunks and dust. DO NOT hose down the area to a storm drain.</p>	<p>1. Block Gutters: EFFECTIVE IMMEDIATELY Dam up gutters to contain slurry and minimize the containment area.</p> <p>Know the location of all nearby storm drain inlets, culverts, and catch basins through which slurry discharges may enter a waterway.</p> <p>If you are within access of a storm drain inlet, block the path to the nearest drain. Either divert flows or berm inlets to pool water away from the drains.</p> <p>2. Minimize Slurry Movement: EFFECTIVE IMMEDIATELY</p> <p>Slurry and sediment from saw cutting or boring operations should be confined to the immediate work area by using temporary berms, sand bags or diversion structures. Minimize the tracking of slurry off site by cars and pedestrians.</p> <p>3. Remove Slurry: MANDATORY JANUARY 1, 2005</p> <p>Efficiently and effectively collect and remove all slurry and runoff from the saw cutting operation as soon as possible. Be sure to include removal of any slurry collected in or near storm drain inlets by pumping to a collection vessel or using a wet/dry vac. It may be necessary to use a street sweeper or wash down the area and collect the water.</p> <p>No slurry or wash water is allowed to drain off site. Slurry and wash water may be disposed of on site, with owners permission, where it can filter into bare soil. Otherwise, dispose of all collected slurry and wash water properly. One way is to allow collected slurry to settle and decant the water onto the ground or, with approval, into the sanitary sewer. Contact Water Pollution Control Facility for approval at 350-9360. Must obtain approval prior to discharging to sanitary sewer. Dispose of the solids appropriately.</p>

DO NOT HOSE DOWN WORK AREAS INTO THE GUTTER, STREET, OR STORM DRAIN. DO NOT WASH IT DOWN PAST THE PROJECT AREA WHERE IT BECOMES "SOME ONE ELSE'S PROBLEM".

Issued: 4/20/2004 Revised: 3/25/2008

STREET, CURB, AND GUTTER REPLACEMENT AND CONSTRUCTION

Activities involving the replacement and construction of streets, curbs, and gutters have the potential to impact storm water quality. Materials involved in these activities should be used efficiently and disposed of properly.

- Applicable sediment and erosion controls should be installed; such as: inlet protection, silt fence, sediment traps, erosion control logs, check dams, and vehicle tracking control. Sediment and erosion controls will be installed and maintained in accordance with approved design criteria and/or industry standards.

- When saw cutting, ensure that no slurry enters the storm drain.**
 - **Block gutters**
 - To contain slurry and minimize the containment area.
 - Protect inlets and pool water away from the drains.
 - **Minimize Slurry Movement**
 - Confine slurry and sediment from saw cutting to immediate work area by using temporary berms, sand bags, or diversion structures.
 - Minimize the tracking of slurry from the job site by cars and pedestrians.
 - **Remove Slurry**
 - Sweep or vacuum slurry and properly dispose of the sweepings or vacuum while saw cutting.
 - Monitor construction equipment for leaks and use drip pans as necessary.
 - Leaking material containers should be properly discarded and replaced.
 - Store materials in containers under cover when not in use and away from any storm drain inlet.
 - Wash out mixers, delivery trucks, or other equipment in the designated concrete washout area only.
 - Locate concrete washout, portable toilets, and material storage away from storm drain inlets.
 - Material stockpiles will not be stored in or near storm water flow lines. Temporary sediment controls will be used during temporary, short-term placement while work is actively occurring.
 - Sweep or vacuum the roadway as needed, during construction and once construction is complete.
 - Best management practices will be periodically inspected and maintained as necessary.
 - Where practicable, non-structural controls will be used, such as phased construction, dust control, good housekeeping practices, and spill prevention and response.
 - Absorbent material should be kept on job site.
 - Concrete Work**
 - Minimize the drift of chemical cure on windy days by using the curing compound sparingly and applying it as close to the concrete surface as possible.
 - Ensure that there is a concrete truck washout area available or require the contractor to wash out at the batch plant.
 - Asphalt Work**
 - Control the placement of road base or asphalt used in embankments or shoulder backing; do not allow these materials to fall into any storm drain or watercourse.
 - Whenever possible, recycle unused asphalt.
 - Traffic Control Devices such as cones may be needed to guard inlet protection devices during certain traffic set-up and flows.



Introduction

Due to the unique issues related to supply chain, financing, contract deadlines, and public need, construction may continue under Governor Polis' stay-at-home order as long as Social Distancing Requirements are followed on construction worksites. This is intended to allow for continuity of operations on critical infrastructure such as roads, rails, airports, housing (especially low-income housing), energy infrastructure and water infrastructure. However, as is reinforced by this guidance, construction projects and companies in their supply chain are **Not Exempt** from social distancing requirements, even if compliance means added cost. Hygiene protocols are **strictly required**. Moreover, people who are sick or at high risk of severe illness from COVID-19 **must not travel to work, even if they work for a Critical Business**. The state also urges any small scale construction projects (e.g. home renovations) to be reasonably deferred without penalty. For large scale and public investment, projects should be evaluated on a case by case basis, in light of the guidance below, related to the stay-at-home order.

Social distancing on construction worksites

Critical functions including construction work **MUST** comply with social distancing requirements. The following practices are important for applying social distancing to a construction worksite setting:

- **Reduce size of work crews:** Teams should reduce the number of people in each work crew to the minimum number of people possible to perform the task safely, even if the reduction of crew size means the job takes longer.
- **Minimize interaction between work teams:** Even groups within the same project should avoid interaction across groups, to minimize possible viral spread if one worker contracts COVID-19. Approaches to avoiding contact between groups may include staggered shifts, compressed work weeks where different teams work different days, and maximizing geographic distance between different teams working on the same project.
- **Avoid contact with visitors:** Visitors outside the typical work crew should avoid interaction with the team wherever possible. For example, if an inspector or materials delivery needs to enter the site, they should alert the work team (e.g. by honking the horn of their vehicle twice or through another established communication means) so that the work team can vacate the site while the external parties are present.
- **Maintain a 6 foot distance between employees wherever possible:** Construction teams should make every effort to limit activities that cannot be performed within 6 feet of distance between

workers. However, some core construction activities may require some proximity to complete (e.g., concrete pours, utility potholing, work in cranes, drainage pipe construction, among others). In these cases, construction crews must employ other aggressive measures to limit contact. Examples include requiring employees to face away from each other, the use of supplemental Personal Protection Equipment (PPE) like face shields or respirators, minimizing the number of people on a team, and retaining consistency within work teams to limit contact with parties external to that team.

- **Office work should be done remotely, whenever possible:** Office functions associated with a project (e.g. accounting or records) should be done from home to the maximum extent practicable.
- **In-person meetings should be avoided:** Office meetings and consultations should take place virtually, with participants working from home or their work truck, whenever possible. If an in-person meeting is absolutely necessary, that must be limited to fewer than ten people, and participants must maintain 6 foot distance at all times during the meetings. All surfaces should be wiped down before and after the meeting, and hand washing should also occur before and after the meeting.
- **Workers must not congregate during breaks:** Construction workers should not congregate for lunch or other breaks.
- **Activity specific work plans:** Contractors should consider all job activities and review how they can be accomplished using necessary social distancing and sanitation protocols.

Hygiene protocols

Strict hygiene protocols must be utilized with all equipment and surface areas that are commonly touched. Operators of light and heavy duty equipment, specifically, must:

- **Clean commonly touched surfaces before and after operation:** *Cleaning:* refers to the removal of germs, dirt, and impurities from surfaces. Cleaning does not kill germs, but by removing them, it lowers their numbers and the risk of spreading infection. Cleaning is typically performed using soap, detergents, cleansers and clean water before using a disinfecting method. Commonly touched surfaces, include but are not limited to: door handles and grab bars, instrument panels, steering wheels, devices such as cell phones;
- **Follow cleaning activities with an approved disinfectant:** refers to using chemicals to kill germs on surfaces. This process does not necessarily clean dirty surfaces or remove germs, but by killing germs on a surface after cleaning, it can further lower the risk of spreading infection. Disinfecting is typically performed using approved commercial or household disinfecting solutions. For a list of CDC-approved disinfectants against viruses (including COVID-19 virus), see: <https://www.epa.gov/pesticide-registration/list-n-disinfectants-use-against-sars-cov-2>
- **Use of personal protective equipment for hygiene and safety:** employees should wear all standard worksite personal protective equipment (PPE), especially eye protection and gloves, as well as other standard safety equipment (e.g. reflective vests or jackets). Face masks should be limited to specific activities for which they are typically needed, because of a national supply shortage. **PPE may not be shared between members of a work team.**

Monitoring employee health and avoiding travel for high risk personnel

- It is critical that individuals DO NOT report to work while they are experiencing illness symptoms including any of the following symptoms: such as; fever, cough, shortness of breath, sore throat, runny/stuffy nose, body aches, nausea, chills, or fatigue. If an employee does experience any of these symptoms, they will notify their foreman or supervisor immediately so that appropriate follow-up actions can be taken. A screening tool for employees can be found [here](#).
- People at high risk of severe illness from COVID-19 are urged to stay in their **Residence at all times** except as necessary to seek medical care. People who are sick must stay in their Residence except as necessary to seek medical care and must not go to work, even at a **Critical Business**.
- **Any worker displaying possible COVID symptoms may not participate in construction work.**
- Employees should monitor their health at the beginning of each work day and are strongly encouraged to check their temperature at the start of the work day (although some COVID-19 cases do not experience a fever).
- Individuals should also seek medical attention if they develop these symptoms by first calling their primary care provider or urgent care center.
- A sick employee must not return to work until they have been asymptomatic for 72 hours. If an employee is diagnosed as positive for COVID-19, they should not return to work until a medical professional has provided written notice that it is safe to do so.

Focus on critical activities

- **Focus on activities that are truly critical:** Not all construction activities are of equal urgency. When considering whether a project is critical, please consider factors such as:
 - Whether the project is under construction already and thus requires active traffic management (in the case of a transportation project) or other work zone safety measures that benefit from ongoing activity;
 - Whether deferral of a start date on a project would undermine public safety or continuity of operations for critical infrastructure;
 - Whether the project can feasibly be done with social distancing measures as detailed above.
- **Encouraging deferral of non-essential work:** All project sponsors, public and private, are encouraged to provide flexibility to construction contractors to enable them to delay work during the period of the Governor's stay at home order. For small projects, especially residential projects such as home renovations, businesses and homeowners are strongly encouraged to provide construction contractors with flexibility to defer work until after the stay at home order is lifted.
- **Safe shutdown of work:** When a project or project phase must be shut down due to the pandemic, care should be taken that the project site is left in a safe condition. Traffic control devices must continue to be inspected and maintained, so it is a best practice to minimize their need and use when a project is temporarily inactive.

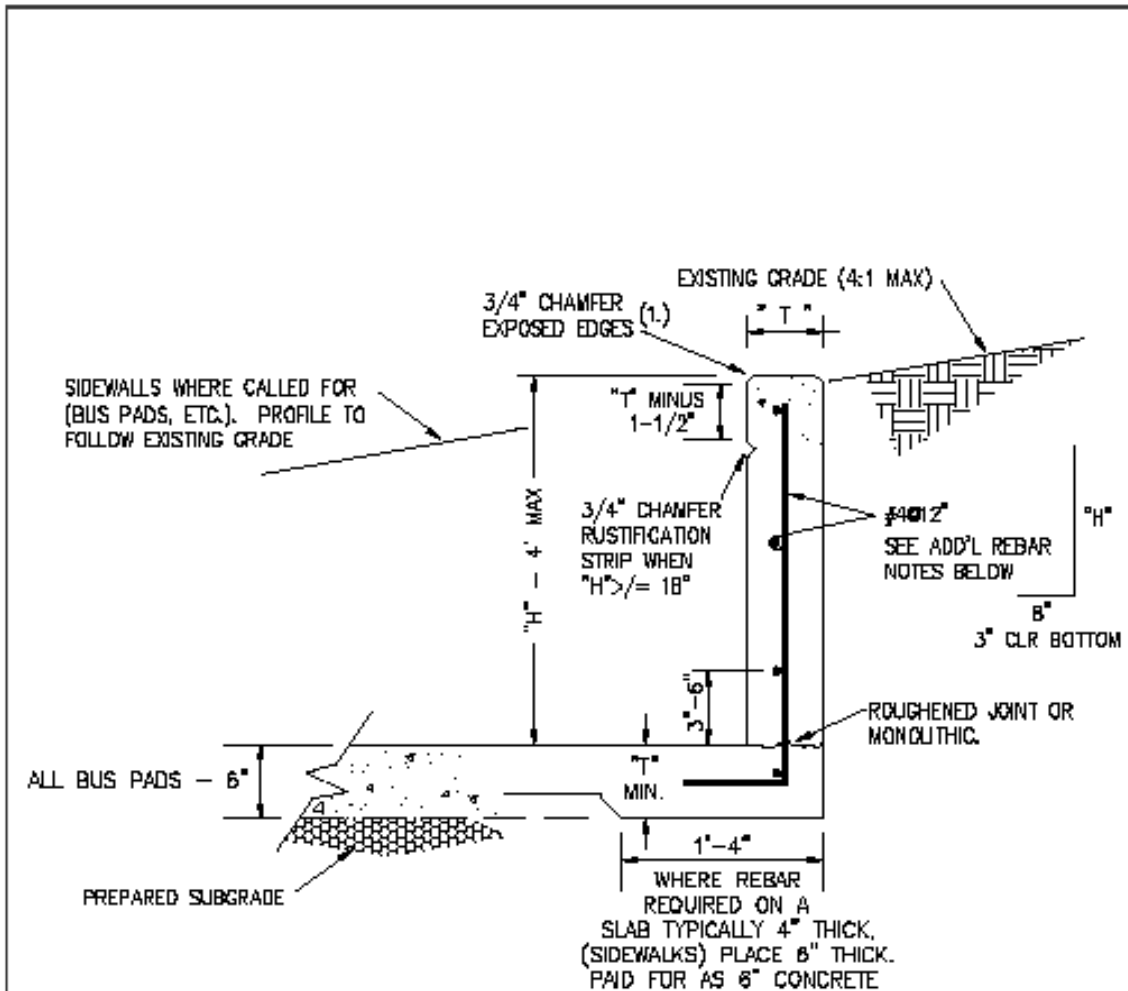

(1.) 3/8" R WHEN "T" = 4", OR IF DIRECTED BY CITY REPRESENTATIVE.

REBAR NOTES:

H	T (MIN)	REBAR
$\leq 6"$	4"	NONE REQ'D
$6" < H < 18"$	6"	NONE REQ'D
$18" \leq H < 48"$	6"	#4@12" CTR'D IN WALL *

* MINIMUM THREE (3) HORIZONTAL BARS IN WALL
TOP BAR 3" FROM TOP OF WALL



City of Greeley
Public Works
Department

LANDSCAPE CURB/RETAINING WALL DETAILS

DETAIL SPECIAL

DATE: JUNE, 2009

SCALE: N.T.S.

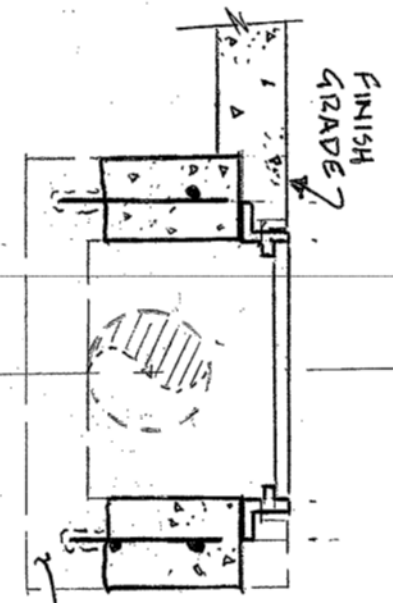

VARIES AS DIRECTED (4" MIN, 24" MAX)

EXIST. CONCRETE INLET BOX

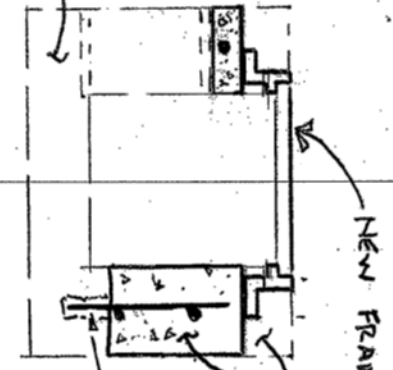

NEW FRAME & GRATE

REMOVE EXISTING BOX WALLS, FORM & PLACE NEW

DRILL & EPOXY NEW REBAR VERTS (IF NECESSARY)

SECTION A-A

SECTION B-B

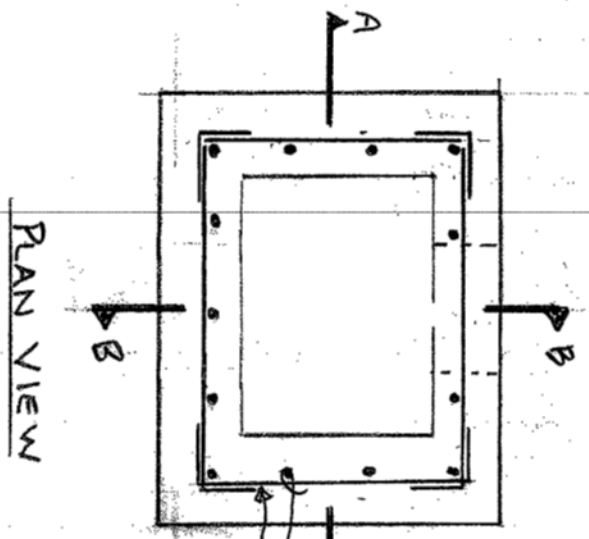

PLAN VIEW

GENERAL NOTES

- NEW GRATE & FRAME -
- CONTINUOUS CORNER REINFORCING (STANDARD ACI HOOKS OR CORNER BARS)
- #4 @ 8" VERT. #4 HORIZ. (1 MIN.)

RECONSTRUCT INLET TOP
DETAIL: NO SCALE

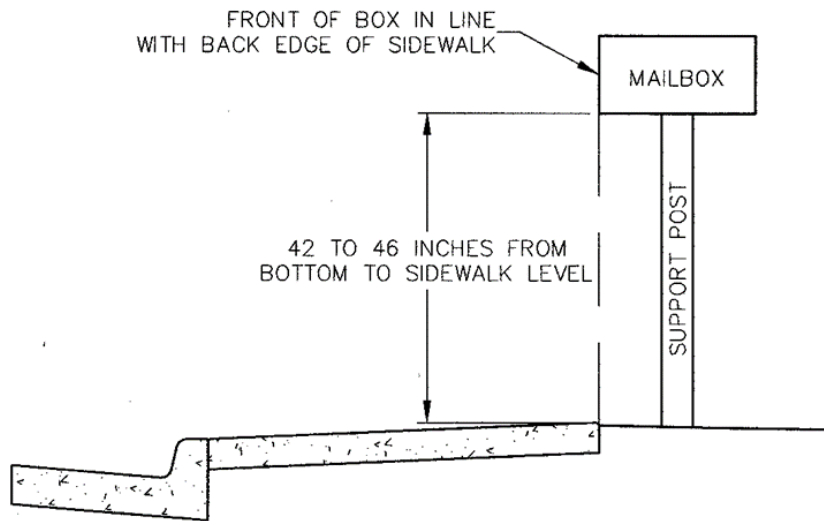

NOTES;

1. MAILBOXES SHALL BE SECURELY FASTENED TO ITS SUPPORT. THE POST MUST BE OF ADEQUATE STRENGTH AND SIZE.
2. MAILBOXES SHALL BE MADE LEVEL AND THE POST FIRMLY PLANTED.
3. CONTRACTOR SHALL PLACE 2 MAILBOXES AT MUTUAL PROPERTY LINES, WHEREVER POSSIBLE.
4. MAILBOXES CANNOT BE ALTERED OR LOCKED, UNLESS THE MAILBOX MEETS OFFICIAL STANDARDS.



TYPICAL CURBSIDE MAILBOX
INSTALLATION
SPECIAL DETAIL

DATE: JULY, 2008

SCALE: N.T.S.

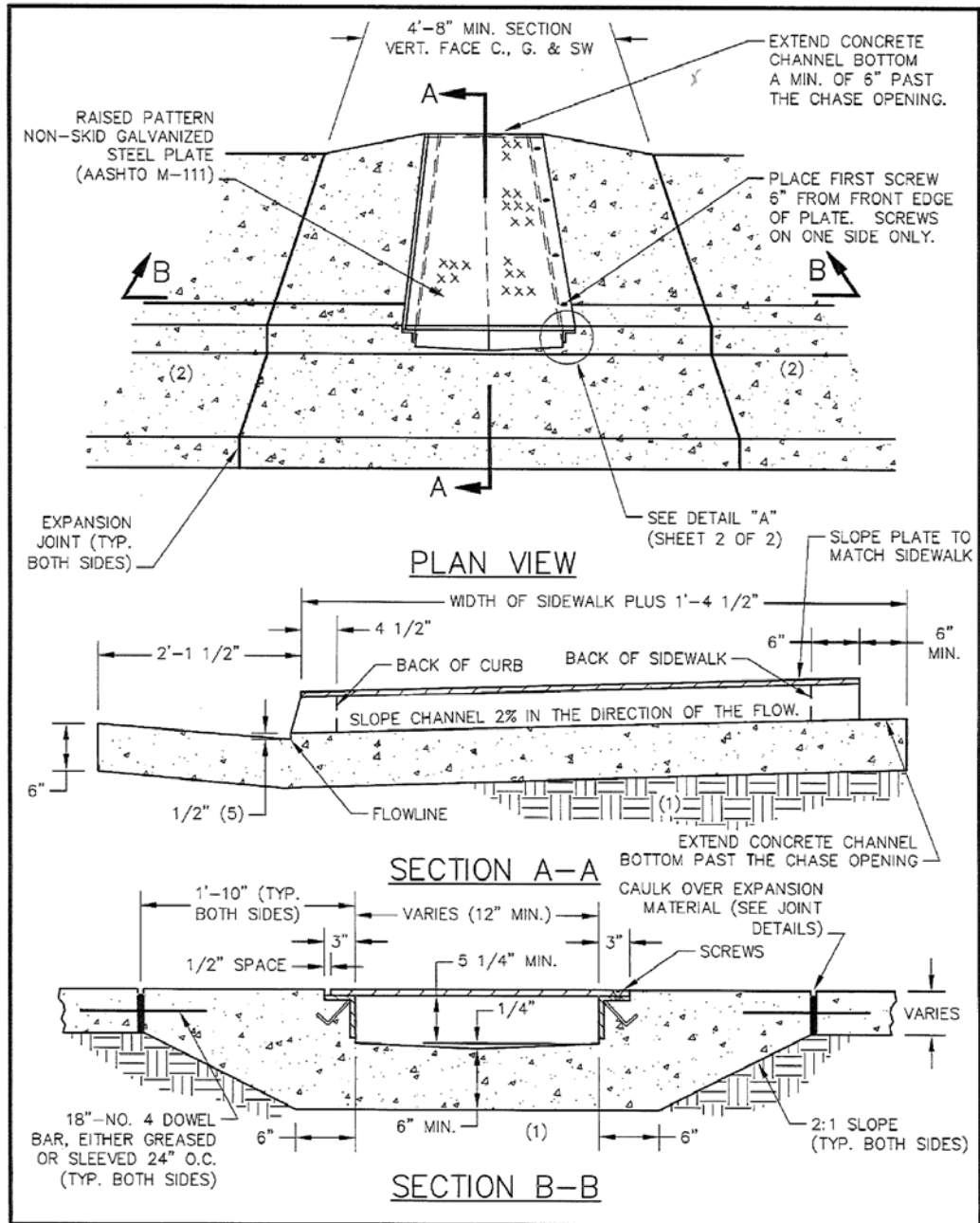

SIDEWALK CHASE FOR ATTACHED SIDEWALK
 SHEET 1 OF 2
 DETAIL NO. S-23-A

DATE: JANUARY, 2008

SCALE: N.T.S.

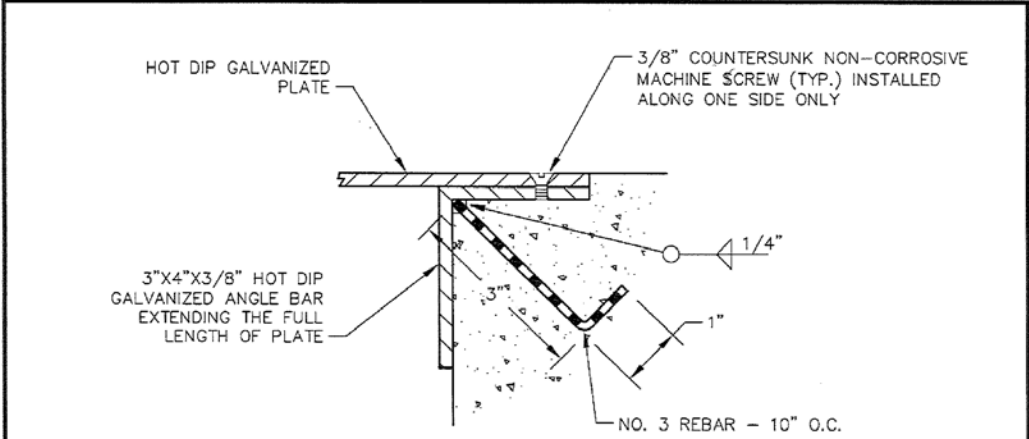

DETAIL "A"

WIDTH OF OPENING	THREADPLATE THICKNESS
12"-18"	9/16"
>18"-24"	5/8"
>24"	SPECIAL DESIGN

NOTES:

1. COMPACTED SUBGRADE (SEE SPECIFICATIONS).
2. FOR DRIVE OVER CURB, GUTTER AND SIDEWALK, TRANSITION (3' MIN.) TO A VERTICAL FACE CURB AND GUTTER FOR CHASE CONSTRUCTION. KEEP GUTTER WIDTH FOR DRIVE OVER.
3. NEENAH R-4999 SERIES BOLTED TRANSVERSE DRAINAGE STRUCTURE, SOLID CHECKERED TYPE D GRATE MAY BE SUBSTITUTED.
4. CONCRETE SURFACES TO RECEIVE A LIGHT BROOM FINISH.
5. ELIMINATE 1/2" FLOWLINE LIP WHEN STORMWATER DRAINS AWAY FROM THE GUTTER.

	<p>SIDEWALK CHASE FOR ATTACHED SIDEWALK SHEET 2 OF 2 DETAIL NO. 2-23-A</p>
DATE: JANUARY, 2008	SCALE: N.T.S.

FEDERALLY REQUIRED CONTRACT CLAUSES

TABLE OF CONTENTS

1. NO GOVERNMENT OBLIGATION TO THIRD PARTIES
2. PROGRAM FRAUD AND FALSE OR FRAUDULENT STATEMENTS AND RELATED ACTS
3. ACCESS TO RECORDS AND REPORTS
4. FEDERAL CHANGES
5. CIVIL RIGHTS REQUIREMENTS
6. ENERGY CONSERVATION REQUIREMENTS
7. TERMINATION
8. GOVERNMENT-WIDE DEBARMENT AND SUSPENSION (NONPROCUREMENT)
9. BREACHES AND DISPUTE RESOLUTION
10. LOBBYING
11. CLEAN AIR
12. CLEAN WATER REQUIREMENTS
13. DAVIS-BACON AND COPELAND ANTI-KICKBACK ACTS
14. CONTRACT WORK HOURS AND SAFETY STANDARDS ACT
15. DRUG AND ALCOHOL TESTING
16. DISADVANTAGED BUSINESS ENTERPRISE (DBE)
17. RECYCLED PRODUCTS
18. ADA ACCESS
19. COMPLIANCE WITH FEDERAL LAW, REGULATIONS, AND EXECUTIVE ORDERS
20. NON-USE OF DHS SEAL, LOGO, AND FLAGS
21. PROCUREMENT OF RECOVERED MATERIALS
22. CHANGES
23. BID PROTEST PROCEDURES

1. NO GOVERNMENT OBLIGATION TO THIRD PARTIES

Applicability to Contracts

Applicable to all contracts.

Flow Down

Not required by statute or regulation for either primary contractors or subcontractors, this concept should flow down to all levels to clarify, to all parties to the contract, that the Federal Government does not have contractual liability to third parties, absent specific written consent.

Model Clause/Language

While no specific language is required, FTA has developed the following language.

No Obligation by the Federal Government.

1. The Purchaser and Contractor acknowledge and agree that, notwithstanding any concurrence by the Federal Government in or approval of the solicitation or award of the underlying contract, absent the express written consent by the Federal Government, the Federal Government is not a party to this contract and shall not be subject to any obligations or liabilities to the Purchaser, Contractor, or any other party (whether or not a party to that contract) pertaining to any matter resulting from the underlying contract.

2. PROGRAM FRAUD AND FALSE OR FRAUDULENT STATEMENTS AND RELATED ACTS

(31 U.S.C. 3801 et seq. 49 CFR Part 31 18 U.S.C. 1001 49 U.S.C. 5307)

Applicability to Contracts

These requirements are applicable to all contracts.

Flow Down

These requirements flow down to contractors and subcontractors who make, present, or submit covered claims and statements.

Model Clause/Language

These requirements have no specified language, so FTA proffers the following language.

Program Fraud and False or Fraudulent Statements or Related Acts.

1. The Contractor acknowledges that the provisions of the Program Fraud Civil Remedies Act of 1986, as amended, 31 U.S.C. § 3801 et seq. and U.S. DOT regulations, "Program Fraud Civil Remedies," 49 C.F.R. Part 31, apply to its actions pertaining to this Project. Upon execution of the underlying contract, the Contractor certifies or affirms the truthfulness and accuracy of any statement it has made, it makes, it may make, or causes to be made, pertaining to the underlying contract or the FTA assisted project for which this contract work is being performed. In addition to other penalties that may be applicable, the Contractor further acknowledges that if it makes, or causes to be made, a false, fictitious, or fraudulent claim, statement, submission, or certification, the Federal Government reserves the right to impose the penalties of the Program Fraud Civil Remedies Act of 1986 on the Contractor to the extent the Federal Government deems

appropriate.

2. The Contractor also acknowledges that if it makes, or causes to be made, a false, fictitious, or fraudulent claim, statement, submission, or certification to the Federal Government under a contract connected with a project that is financed in whole or in part with Federal assistance originally awarded by FTA under the authority of 49 U.S.C. § 5307, the Government reserves the right to impose the penalties of 18 U.S.C. § 1001 and 49 U.S.C. § 5307(n)(1) on the Contractor, to the extent the Federal Government deems appropriate.
3. The Contractor agrees to include the above two clauses in each subcontract financed in whole or in part with Federal assistance provided by FTA. It is further agreed that the clauses shall not be modified, except to identify the subcontractor who will be subject to the provisions.

3. ACCESS TO RECORDS AND REPORTS

(49 U.S.C. 5325, 18 CFR 18.36 (i), 49 CFR 633.17)

Applicability to Contracts

Reference Chart "Requirements for Access to Records and Reports by Type of Contracts"

Flow Down

FTA does not require the inclusion of these requirements in subcontracts.

Model Clause/Language

The specified language is not mandated by the statutes or regulations referenced, but the language provided paraphrases the statutory or regulatory language.

Access to Records - The following access to records requirements apply to this Contract:

1. Where the Purchaser is not a State but a local government and is the FTA Recipient or a subgrantee of the FTA Recipient in accordance with 49 C.F.R. 18.36(i), the Contractor agrees to provide the Purchaser, the FTA Administrator, the Comptroller General of the United States or any of their authorized representatives access to any books, documents, papers and records of the Contractor which are directly pertinent to this contract for the purposes of making audits, examinations, excerpts and transcriptions. Contractor also agrees, pursuant to 49 C.F.R. 633.17 to provide the FTA Administrator or his authorized representatives including any PMO Contractor access to Contractor's records and construction sites pertaining to a major capital project, defined at 49 U.S.C. 5302(a)1, which is receiving federal financial assistance through the programs described at 49 U.S.C. 5307, 5309 or 5311.
2. Where the Purchaser is a State and is the FTA Recipient or a subgrantee of the FTA Recipient in accordance with 49 C.F.R. 633.17, Contractor agrees to provide the Purchaser, the FTA Administrator or his authorized representatives, including any PMO Contractor, access to the Contractor's records and construction sites pertaining to a major capital project, defined at 49 U.S.C. 5302(a)1, which is receiving federal financial assistance through the programs described at 49 U.S.C. 5307, 5309 or 5311. By definition, a major capital project excludes contracts of less than the simplified acquisition threshold currently set at \$100,000.

3. Where the Purchaser enters into a negotiated contract for other than a small purchase or under the simplified acquisition threshold and is an institution of higher education, a hospital or other non-profit organization and is the FTA Recipient or a subgrantee of the FTA Recipient in accordance with 49 C.F.R. 19.48, Contractor agrees to provide the Purchaser, FTA Administrator, the Comptroller General of the United States or any of their duly authorized representatives with access to any books, documents, papers and record of the Contractor which are directly pertinent to this contract for the purposes of making audits, examinations, excerpts and transcriptions.
4. Where any Purchaser which is the FTA Recipient or a subgrantee of the FTA Recipient in accordance with 49 U.S.C. 5325(a) enters into a contract for a capital project or improvement (defined at 49 U.S.C. 5302(a)1) through other than competitive bidding, the Contractor shall make available records related to the contract to the Purchaser, the Secretary of Transportation and the Comptroller General or any authorized officer or employee of any of them for the purposes of conducting an audit and inspection.
5. The Contractor agrees to permit any of the foregoing parties to reproduce by any means whatsoever or to copy excerpts and transcriptions as reasonably needed.
6. The Contractor agrees to maintain all books, records, accounts and reports required under this contract for a period of not less than three years after the date of termination or expiration of this contract, except in the event of litigation or settlement of claims arising from the performance of this contract, in which case Contractor agrees to maintain same until the Purchaser, the FTA Administrator, the Comptroller General, or any of their duly authorized representatives, have disposed of all such litigation, appeals, claims or exceptions related thereto. Reference 49 CFR 18.39(i)(11).
7. FTA does not require the inclusion of these requirements in subcontracts.

Requirements for Access to Records and Reports by Types of Contract

Contract Characteristics	Operational Service Contract	Turnkey	Construction	Architectural Engineering	Acquisition of Rolling Stock	Professional Services
<u>I State Grantees</u>						
a. Contracts below SAT (\$100,000)	None	Those imposed on state pass thru to Contractor	None	None	None	None
b. Contracts above \$100,000/Capital Projects	None unless ¹ non-competitive award		Yes, if non-competitive award or if funded thru ² 5307/5309/5311	None unless non-competitive award	None unless non-competitive award	None unless non-competitive award
<u>II Non State Grantees</u>						
a. Contracts below SAT (\$100,000)	Yes ³	Those imposed on state pass thru to Contractor	Yes	Yes	Yes	Yes
b. Contracts above \$100,000/Capital Projects	Yes ³	Those imposed on state pass thru to Contractor	Yes	Yes	Yes	Yes

Sources of Authority:

¹ 49 USC 5325 (a)

² 49 CFR 633.17

³ 18 CFR 18.36 (i)

4. FEDERAL CHANGES

(49 CFR Part 18)

Applicability to Contracts

The Federal Changes requirement applies to all contracts.

Flow Down

The Federal Changes requirement flows down appropriately to each applicable changed requirement.

Model Clause/Language

No specific language is mandated. The following language has been developed.

Federal Changes - Contractor shall at all times comply with all applicable regulations, policies, procedures and directives, including without limitation those listed directly or by reference in the Master Agreement between Purchaser and FEMA, as they may be amended or promulgated from time to time during the term of this contract. Contractor's failure to so comply shall constitute a material breach of this contract.

5. CIVIL RIGHTS REQUIREMENTS

(29 U.S.C. § 623, 42 U.S.C. § 2000 42 U.S.C. § 6102, 42 U.S.C. § 12112 42 U.S.C. § 12132, 49 U.S.C. § 5332 29 CFR Part 1630, 41 CFR Parts 60 et seq.)

Applicability to Contracts

The Civil Rights Requirements apply to all contracts.

Flow Down

The Civil Rights requirements flow down to all third-party contractors and their contracts at every tier.

Model Clause/Language

The following clause was predicated on language contained at 49 CFR Part 19, Appendix A, but FTA has shortened the lengthy text.

Civil Rights - The following requirements apply to the underlying contract:

1. **Nondiscrimination** - In accordance with Title VI of the Civil Rights Act, as amended, 42 U.S.C. § 2000d, section 303 of the Age Discrimination Act of 1975, as amended, 42 U.S.C. § 6102, section 202 of the Americans with Disabilities Act of 1990, 42 U.S.C. § 12132, and Federal transit law at 49 U.S.C. § 5332, the Contractor agrees that it will not discriminate against any employee or applicant for employment because of race, color, creed, national origin, sex, age, or disability. In addition, the Contractor agrees to comply with applicable Federal implementing regulations and other implementing requirements FTA may issue.
2. **Equal Employment Opportunity** - The following equal employment opportunity requirements apply to the underlying contract:
 - a) **Race, Color, Creed, National Origin, Sex** - In accordance with Title VII of the Civil Rights Act, as amended, 42 U.S.C. § 2000e, and Federal transit laws at 49 U.S.C. § 5332, the Contractor agrees to comply with all applicable equal employment

opportunity requirements of U.S. Department of Labor (U.S. DOL) regulations, "Office of Federal Contract Compliance Programs, Equal Employment Opportunity, Department of Labor," 41 C.F.R. Parts 60 et seq., (which implement Executive Order No. 11246, "Equal Employment Opportunity," as amended by Executive Order No. 11375, "Amending Executive Order 11246 Relating to Equal Employment Opportunity," 42 U.S.C. § 2000e note), and with any applicable Federal statutes, executive orders, regulations, and Federal policies that may in the future affect construction activities undertaken in the course of the Project. The Contractor agrees to take affirmative action to ensure that applicants are employed, and that employees are treated during employment, without regard to their race, color, creed, national origin, sex, or age. Such action shall include, but not be limited to, the following: employment, upgrading, demotion or transfer, recruitment or recruitment advertising, layoff or termination; rates of pay or other forms of compensation; and selection for training, including apprenticeship. In addition, the Contractor agrees to comply with any implementing requirements FTA may issue.

- b) Age - In accordance with section 4 of the Age Discrimination in Employment Act of 1967, as amended, 29 U.S.C. § § 623 and Federal transit law at 49 U.S.C. § 5332, the Contractor agrees to refrain from discrimination against present and prospective employees for reason of age. In addition, the Contractor agrees to comply with any implementing requirements FTA may issue.
 - c) Disabilities - In accordance with section 102 of the Americans with Disabilities Act, as amended, 42 U.S.C. § 12112, the Contractor agrees that it will comply with the requirements of U.S. Equal Employment Opportunity Commission, "Regulations to Implement the Equal Employment Provisions of the Americans with Disabilities Act," 29 C.F.R. Part 1630, pertaining to employment of persons with disabilities. In addition, the Contractor agrees to comply with any implementing requirements FTA may issue.
 - d) Special DOL EEO Clause - In addition to the foregoing, when undertaking "construction" as recognized by the U.S. Department of Labor (U.S. DOL), the Recipient agrees to comply, and assures that each Third Party Participant will comply, with: (a) U.S. DOL regulations, "Office of Federal Contract Compliance Programs, Equal Employment Opportunity, Department of Labor," 41 C.F.R. chapter 60, and (b) Executive Order 11246, "Equal Employment Opportunity," as amended by Executive Order 11375, "Amending Executive Order 11246, Relating to Equal Employment Opportunity," 42 U.S.C. § 2000e note.
3. The Contractor also agrees to include these requirements in each subcontract financed in whole or in part with Federal assistance provided by FTA, modified only if necessary to identify the affected parties.

6. ENERGY CONSERVATION REQUIREMENTS

(42 U.S.C. 6321 et seq. 49 CFR Part 18)

Applicability to Contracts

The Energy Conservation requirements are applicable to all contracts.

Flow Down

The Energy Conservation requirements extend to all third-party contractors and their contracts at every tier and subrecipients and their sub agreements at every tier.

Model Clause/Language

No specific clause is recommended in the regulations because the Energy Conservation requirements are so dependent on the state energy conservation plan. The following language has been developed by FTA:

Energy Conservation - The contractor agrees to comply with mandatory standards and policies relating to energy efficiency which are contained in the state energy conservation plan issued in compliance with the Energy Policy and Conservation Act.

7. TERMINATION

(49 U.S.C. Part 18 FTA Circular 4220.1E)

Applicability to Contracts

All contracts (with the exception of contracts with nonprofit organizations and institutions of higher education,) in excess of \$10,000 shall contain suitable provisions for termination by the grantee including the manner by which it will be effected and the basis for settlement. (For contracts with nonprofit organizations and institutions of higher education the threshold is \$100,000.) In addition, such contracts shall describe conditions under which the contract may be terminated for default as well as conditions where the contract may be terminated because of circumstances beyond the control of the contractor.

Flow Down

The termination requirements flow down to all contracts in excess of \$10,000, with the exception of contracts with nonprofit organizations and institutions of higher learning.

Model Clause/Language

FTA does not prescribe the form or content of such clauses. The following are suggestions of clauses to be used in different types of contracts:

- a. **Termination for Convenience (General Provision)** The (Recipient) may terminate this contract, in whole or in part, at any time by written notice to the Contractor when it is in the Government's best interest. The Contractor shall be paid its costs, including contract close-out costs, and profit on work performed up to the time of termination. The Contractor shall promptly submit its termination claim to (Recipient) to be paid the Contractor. If the Contractor has any property in its possession belonging to the (Recipient), the Contractor will account for the same, and dispose of it in the manner the (Recipient) directs.
- b. **Termination for Default [Breach or Cause] (General Provision)** If the Contractor does not deliver supplies in accordance with the contract delivery schedule, or, if the contract is for services, the Contractor fails to perform in the manner called for in the contract, or if the Contractor fails to comply with any other provisions of the contract, the (Recipient) may terminate this contract for default. Termination shall be effected by serving a notice of termination on the contractor setting forth the manner in which the Contractor is in default. The contractor will only be paid the contract price for supplies delivered and accepted, or services performed in accordance with the manner of performance set forth in the contract.

If it is later determined by the (Recipient) that the Contractor had an excusable reason for not performing, such as a strike, fire, or flood, events which are not the fault of or are beyond the control of the Contractor, the (Recipient), after setting up a new delivery of performance schedule, may allow the Contractor to continue work, or treat the termination as a termination for convenience.

- c. **Opportunity to Cure (General Provision)** The (Recipient) in its sole discretion may, in

the case of a termination for breach or default, allow the Contractor [an appropriately short period of time] in which to cure the defect. In such case, the notice of termination will state the time period in which cure is permitted and other appropriate conditions

If Contractor fails to remedy to (Recipient)'s satisfaction the breach or default of any of the terms, covenants, or conditions of this Contract within [ten (10) days] after receipt by Contractor of written notice from (Recipient) setting forth the nature of said breach or default, (Recipient) shall have the right to terminate the Contract without any further obligation to Contractor. Any such termination for default shall not in any way operate to preclude (Recipient) from also pursuing all available remedies against Contractor and its sureties for said breach or default.

- d. Waiver of Remedies for any Breach** In the event that (Recipient) elects to waive its remedies for any breach by Contractor of any covenant, term or condition of this Contract, such waiver by (Recipient) shall not limit (Recipient)'s remedies for any succeeding breach of that or of any other term, covenant, or condition of this Contract.
- e. Termination for Convenience (Professional or Transit Service Contracts)** The (Recipient), by written notice, may terminate this contract, in whole or in part, when it is in the Government's interest. If this contract is terminated, the Recipient shall be liable only for payment under the payment provisions of this contract for services rendered before the effective date of termination.
- f. Termination for Default (Supplies and Service)** If the Contractor fails to deliver supplies or to perform the services within the time specified in this contract or any extension or if the Contractor fails to comply with any other provisions of this contract, the (Recipient) may terminate this contract for default. The (Recipient) shall terminate by delivering to the Contractor a Notice of Termination specifying the nature of the default. The Contractor will only be paid the contract price for supplies delivered and accepted, or services performed in accordance with the manner or performance set forth in this contract.

If, after termination for failure to fulfill contract obligations, it is determined that the Contractor was not in default, the rights and obligations of the parties shall be the same as if the termination had been issued for the convenience of the Recipient.

- g. Termination for Convenience of Default (Cost-Type Contracts)** The (Recipient) may terminate this contract, or any portion of it, by serving a notice of termination on the Contractor. The notice shall state whether the termination is for convenience of the (Recipient) or for the default of the Contractor. If the termination is for default, the notice shall state the manner in which the contractor has failed to perform the requirements of the contract. The Contractor shall account for any property in its possession paid for from funds received from the (Recipient), or property supplied to the Contractor by the (Recipient). If the termination is for default, the (Recipient) may fix the fee, if the contract provides for a fee, to be paid the contractor in proportion to the value, if any, of work performed up to the time of termination. The Contractor shall promptly submit its termination claim to the (Recipient) and the parties shall negotiate the termination settlement to be paid the Contractor.

If the termination is for the convenience of the (Recipient), the Contractor shall be paid its contract close-out costs, and a fee, if the contract provided for payment of a fee, in proportion to the work performed up to the time of termination.

If, after serving a notice of termination for default, the (Recipient) determines that the Contractor has an excusable reason for not performing, such as strike, fire, flood, events which are not the fault of and are beyond the control of the contractor, the (Recipient), after setting up a new work schedule, may allow the Contractor to continue work, or treat the termination as a termination for convenience.

8. GOVERNMENT-WIDE DEBARMENT AND SUSPENSION (NONPROCUREMENT)

Background and Applicability

In conjunction with the Office of Management and Budget and other affected Federal agencies, DOT published an update to 49 CFR Part 29 on November 26, 2003. This government-wide regulation implements Executive Order 12549, *Debarment and Suspension*, Executive Order 12689, *Debarment and Suspension*, and 31 U.S.C. 6101 note (Section 2455, Public Law 103-355, 108 Stat. 3327).

The provisions of Part 29 apply to all grantee contracts and subcontracts at any level expected to equal or exceed \$25,000 as well as any contract or subcontract (at any level) for Federally required auditing services. 49 CFR 29.220(b). This represents a change from prior practice in that the dollar threshold for application of these rules has been lowered from

\$100,000 to \$25,000. These are contracts and subcontracts referred to in the regulation as "covered transactions."

Grantees, contractors, and subcontractors (at any level) that enter into covered transactions are required to verify that the entity (as well as its principals and affiliates) they propose to contract or subcontract with is not excluded or disqualified. They do this by (a) Checking the Excluded Parties List System, (b) Collecting a certification from that person, or (c) Adding a clause or condition to the contract or subcontract. This represents a change from prior practice in that certification is still acceptable but is no longer required. 49 CFR 29.300.

Grantees, contractors, and subcontractors who enter into covered transactions also must require the entities they contract with to comply with 49 CFR 29, subpart C and include this requirement in their own subsequent covered transactions (i.e., the requirement flows down to subcontracts at all levels).

Clause Language

The following clause language is suggested, not mandatory. It incorporates the optional method of verifying that contractors are not excluded or disqualified by certification.

Suspension and Debarment

This contract is a covered transaction for purposes of 49 CFR Part 29. As such, the contractor is required to verify that none of the contractor, its principals, as defined at 49 CFR 29.995, or affiliates, as defined at 49 CFR 29.905, are excluded or disqualified as defined at 49 CFR 29.940 and 29.945.

The contractor is required to comply with 49 CFR 29, Subpart C and must include the requirement to comply with 49 CFR 29, Subpart C in any lower tier covered transaction it enters into.

By signing and submitting its bid or proposal, the bidder or proposer certifies as follows: The certification in this clause is a material representation of fact relied upon by the City of Greeley. If it is later determined that the bidder or proposer knowingly rendered an erroneous certification, in addition to remedies available to the City of Greeley, the Federal Government may pursue available remedies, including but not limited to suspension and/or debarment. The bidder or proposer agrees to comply with the requirements of 49 CFR 29, Subpart C while this offer is valid and throughout the period of any contract that may arise from this offer. The bidder or proposer further agrees to include a provision requiring such compliance in its lower tier covered transactions.

9. BREACHES AND DISPUTE RESOLUTION

(49 CFR Part 18FTA Circular 4220.1E)

Applicability to Contracts

All contracts in excess of \$100,000 shall contain provisions or conditions which will allow for administrative, contractual, or legal remedies in instances where contractors violate or breach contract terms, and provide for such sanctions and penalties as may be appropriate. This may include provisions for bonding, penalties for late or inadequate performance, retained earnings, liquidated damages or other appropriate measures.

Flow Down

The Breaches and Dispute Resolutions requirements flow down to all tiers.

Model Clauses/Language

FTA does not prescribe the form or content of such provisions. What provisions are developed will depend on the circumstances and the type of contract. Recipients should consult legal counsel in developing appropriate clauses. The following clauses are examples of provisions from various FTA third party contracts.

Disputes - Disputes arising in the performance of this Contract which are not resolved by agreement of the parties shall be decided in writing by the authorized representative of (Recipient)'s [title of employee]. This decision shall be final and conclusive unless within [ten (10)] days from the date of receipt of its copy, the Contractor mails or otherwise furnishes a written appeal to the [title of employee]. In connection with any such appeal, the Contractor shall be afforded an opportunity to be heard and to offer evidence in support of its position. The decision of the [title of employee] shall be binding upon the Contractor and the Contractor shall abide by the decision.

Performance During Dispute - Unless otherwise directed by (Recipient), Contractor shall continue performance under this Contract while matters in dispute are being resolved.

Claims for Damages - Should either party to the Contract suffer injury or damage to person or property because of any act or omission of the party or of any of his employees, agents or others for whose acts he is legally liable, a claim for damages therefor shall be made in writing to such other party within a reasonable time after the first observance of such injury or damage.

Remedies - Unless this contract provides otherwise, all claims, counterclaims, disputes and other matters in question between the (Recipient) and the Contractor arising out of or relating to this agreement or its breach will be decided by arbitration if the parties mutually agree, or in a court of competent jurisdiction within the State in which the (Recipient) is located.

Rights and Remedies - The duties and obligations imposed by the Contract Documents and the rights and remedies available thereunder shall be in addition to and not a limitation of any duties, obligations, rights and remedies otherwise imposed or available by law. No action or failure to act by the (Recipient), (Architect) or Contractor shall constitute a waiver of any right or duty afforded any of them under the Contract, nor shall any such action or failure to act constitute an approval of or acquiescence in any breach thereunder, except as may be specifically agreed in writing.

10. LOBBYING

(31 U.S.C. 1352 49 CFR Part 19 49 CFR Part 20)

Applicability to Contracts

The Lobbying requirements apply to Construction/Architectural and

Engineering/Acquisition of Rolling Stock/Professional Service Contract/Operational Service Contract/Turnkey contracts.

Flow Down

The Lobbying requirements mandate the maximum flow down, pursuant to Byrd Anti-Lobbying Amendment, 31 U.S.C. § 1352(b)(5) and 49 C.F.R. Part 19, Appendix A, Section 7.

Mandatory Clause/Language

Clause and specific language therein are mandated by 49 CFR Part 19, Appendix A.

Modifications have been made to the Clause pursuant to Section 10 of the Lobbying Disclosure Act of 1995, P.L. 104-65 [to be codified at 2 U.S.C. § 1601, *et seq.*]

- Lobbying Certification and Disclosure of Lobbying Activities for third party contractors are mandated by 31 U.S.C. 1352(b)(5), as amended by Section 10 of the Lobbying Disclosure Act of 1995, and DOT implementing regulation, "New Restrictions on Lobbying," at 49 CFR § 20.110(d)
- Language in Lobbying Certification is mandated by 49 CFR Part 19, Appendix A, Section 7, which provides that contractors file the certification required by 49 CFR Part 20, Appendix A.

Modifications have been made to the Lobbying Certification pursuant to Section 10 of the Lobbying Disclosure Act of 1995.

- Use of "Disclosure of Lobbying Activities," Standard Form-LLL set forth in Appendix B of 49 CFR Part 20, as amended by "Government wide Guidance For New Restrictions on Lobbying," 61 Fed. Reg. 1413 (1/19/96) is mandated by 49 CFR Part 20, Appendix A.

Byrd Anti-Lobbying Amendment, 31 U.S.C. 1352, as amended by the Lobbying Disclosure Act of 1995, P.L. 104-65 [to be codified at 2 U.S.C. § 1601, *et seq.*]

Contractors who apply or bid for an award of \$100,000 or more shall file the certification required by 49 CFR part 20, "New Restrictions on Lobbying." Each tier certifies to the tier above that it will not and has not used Federal appropriated funds to pay any person or organization for influencing or attempting to influence an officer or employee of any agency, a member of Congress, officer or employee of Congress, or an employee of a member of Congress in connection with obtaining any Federal contract, grant or any other award covered by 31 U.S.C. 1352. Each tier shall also disclose the name of any registrant under the Lobbying Disclosure Act of 1995 who has made lobbying contacts on its behalf with non- Federal funds with respect to that Federal contract, grant or award covered by 31 U.S.C. 1352. Such disclosures are forwarded from tier to tier up to the recipient.

APPENDIX A, 49 CFR PART 20--CERTIFICATION REGARDING LOBBYING

Certification for Contracts, Grants, Loans, and Cooperative Agreements

(To be submitted with each bid or offer exceeding \$100,000)

The undersigned [Contractor] certifies, to the best of his or her knowledge and belief, that:

- (1) No Federal appropriated funds have been paid or will be paid, by or on behalf of the undersigned, to any person for influencing or attempting to influence an officer or employee of an agency, a Member of Congress, an officer or employee of Congress, or
an employee of a Member of Congress in connection with the awarding of any Federal contract, the making of any Federal grant, the making of any Federal loan, the entering into of any cooperative agreement, and the extension, continuation,

renewal, amendment, or modification of any Federal contract, grant, loan, or cooperative agreement.

- (2) If any funds other than Federal appropriated funds have been paid or will be paid to any person for making lobbying contacts to an officer or employee of any agency, a Member of Congress, an officer or employee of Congress, or an employee of a Member of Congress in connection with this Federal contract, grant, loan, or cooperative agreement, the undersigned shall complete and submit Standard Form-LLL, "Disclosure Form to Report Lobbying," in accordance with its instructions [as amended by "Government wide Guidance for New Restrictions on Lobbying," 61 Fed. Reg. 1413 (1/19/96). Note: Language in paragraph (2) herein has been modified in accordance with Section 10 of the Lobbying Disclosure Act of 1995 (P.L. 104-65, to be codified at 2 U.S.C. 1601, *et seq.*)]
- (3) The undersigned shall require that the language of this certification be included in the award documents for all subawards at all tiers (including subcontracts, subgrants, and contracts under grants, loans, and cooperative agreements) and that all subrecipients shall certify and disclose accordingly.

This certification is a material representation of fact upon which reliance was placed when this transaction was made or entered into. Submission of this certification is a prerequisite for making or entering into this transaction imposed by 31, U.S.C. § 1352 (as amended by the Lobbying Disclosure Act of 1995). Any person who fails to file the required certification shall be subject to a civil penalty of not less than \$10,000 and not more than \$100,000 for each such failure.

[Note: Pursuant to 31 U.S.C. § 1352(c)(1)-(2)(A), any person who makes a prohibited expenditure or fails to file or amend a required certification or disclosure form shall be subject to a civil penalty of not less than \$10,000 and not more than \$100,000 for each such expenditure or failure.]

The Contractor, _____, certifies or affirms the truthfulness and accuracy of each statement of its certification and disclosure, if any. In addition, the Contractor understands and agrees that the provisions of 31 U.S.C. A 3801, *et seq.*, apply to this certification and disclosure, if any.

_____ Signature of Contractor's Authorized Official

_____ Name and Title of Contractor's Authorized Official

_____ Date

11. CLEAN AIR

(42 U.S.C. 7401 *et seq.*, 40 CFR 15.61, 49 CFR Part 18)

Applicability to Contracts

The Clean Air requirements apply to all contracts exceeding \$100,000, including indefinite quantities where the amount is expected to exceed \$100,000 in any year.

Flow Down

The Clean Air requirements flow down to all subcontracts which exceed \$100,000.

Model Clauses/Language

No specific language is required. FTA has proposed the following language.

Clean Air - (1) The Contractor agrees to comply with all applicable standards, orders or regulations issued pursuant to the Clean Air Act, as amended, 42 U.S.C. §§ 7401 et seq. The Contractor agrees to report each violation to the Purchaser and understands and agrees that the Purchaser will, in turn, report each violation as required to assure notification to FTA and the appropriate EPA Regional Office.

(2) The Contractor also agrees to include these requirements in each subcontract exceeding \$100,000 financed in whole or in part with Federal assistance provided by FTA.

12. CLEAN WATER REQUIREMENTS

(33 U.S.C. 1251)

Applicability to Contracts

The Clean Water requirements apply to each contract and subcontract which exceeds \$100,000.

Flow Down

The Clean Water requirements flow down to FTA recipients and subrecipients at every tier.

Model Clause/Language

While no mandatory clause is contained in the Federal Water Pollution Control Act, as amended, the following language developed by FTA contains all the mandatory requirements:

Clean Water - (1) The Contractor agrees to comply with all applicable standards, orders or regulations issued pursuant to the Federal Water Pollution Control Act, as amended, 33 U.S.C. 1251 et seq. The Contractor agrees to report each violation to the Purchaser and understands and agrees that the Purchaser will, in turn, report each violation as required to assure notification to FTA and the appropriate EPA Regional Office.

(2) The Contractor also agrees to include these requirements in each subcontract exceeding \$100,000 financed in whole or in part with Federal assistance provided by FTA.

13. DAVIS-BACON AND COPELAND ANTI-KICKBACK

ACTS Background and Application

The Davis-Bacon and Copeland Acts are codified at 40 USC 3141, *et seq.* and 18 USC 874. The Acts apply to grantee construction contracts and subcontracts that “at least partly are financed by a loan or grant from the Federal Government.” 40 USC 3145(a), 29 CFR 5.2(h), 49 CFR 18.36(i)(5). The Acts apply to any construction contract over \$2,000. 40 USC 3142(a), 29 CFR 5.5(a). ‘Construction,’ for purposes of the Acts, includes “actual construction, alteration and/or repair, including painting and decorating.” 29 CFR 5.5(a). The requirements of both Acts are incorporated into a single clause (see 29 CFR 3.11) enumerated at 29 CFR 5.5(a) and reproduced below.

The clause language is drawn directly from 29 CFR 5.5(a) and any deviation from the model clause below should be coordinated with counsel to ensure the Acts’ requirements are satisfied.

Clause Language

Davis-Bacon and Copeland Anti-Kickback Acts

- (1) **Minimum wages** - (i) All laborers and mechanics employed or working upon the site of the work (or under the United States Housing Act of 1937 or under the Housing Act of 1949 in the construction or development of the project), will be paid unconditionally and not less often than once a week, and without subsequent deduction or rebate on any account (except such payroll deductions as are permitted by regulations issued by the Secretary of Labor under the Copeland Act (29 CFR part 3)), the full amount of wages and bona fide fringe benefits (or cash equivalents thereof) due at time of payment computed at rates not less than those contained in the wage determination of the Secretary of Labor which is attached hereto and made a part hereof, regardless of any contractual relationship which may be alleged to exist between the contractor and such laborers and mechanics.

Contributions made or costs reasonably anticipated for bona fide fringe benefits under section 1(b)(2) of the Davis-Bacon Act on behalf of laborers or mechanics are considered wages paid to such laborers or mechanics, subject to the provisions of paragraph (1)(iv) of this section; also, regular contributions made or costs incurred for more than a weekly period (but not less often than quarterly) under plans, funds, or programs which cover the particular weekly period, are deemed to be constructively made or incurred during such weekly period. Such laborers and mechanics shall be paid the appropriate wage rate and fringe benefits on the wage determination for the classification of work actually performed, without regard to skill, except as provided in 29 CFR Part 5.5(a)(4). Laborers or mechanics performing work in more than one classification may be compensated at the rate specified for each classification for the time actually worked therein: Provided, That the employer's payroll records accurately set forth the time spent in each classification in which work is performed. The wage determination (including any additional classifications and wage rates conformed under paragraph (1)(ii) of this section) and the Davis-Bacon poster (WH-1321) shall be posted at all times by the contractor and its subcontractors at the site of the work in a prominent and accessible place where it can be easily seen by the workers.

- (ii) (A) The contracting officer shall require that any class of laborers or mechanics, including helpers, which is not listed in the wage determination and which is to be employed under the contract shall be classified in conformance with the wage determination. The contracting officer shall approve an additional classification and wage rate and fringe benefits therefore only when the following criteria have been met:
- (1) Except with respect to helpers as defined as 29 CFR 5.2(n)(4), the work to be performed by the classification requested is not performed by a classification in the wage determination; and
 - (2) The classification is utilized in the area by the construction industry; and
 - (3) The proposed wage rate, including any bona fide fringe benefits, bears a reasonable relationship to the wage rates contained in the wage determination; and
 - (4) With respect to helpers as defined in 29 CFR 5.2(n)(4), such a classification prevails in the area in which the work is performed.
- (B) If the contractor and the laborers and mechanics to be employed in the classification (if known), or their representatives, and the contracting officer agree on the classification and wage rate (including the amount designated for fringe benefits where appropriate), a report of the action taken shall be sent by the contracting officer to the Administrator of the Wage and Hour

Division, Employment Standards Administration, U.S. Department of Labor, Washington, DC 20210. The Administrator, or an authorized representative, will approve, modify, or disapprove every additional classification action within 30 days of receipt and so advise the contracting officer or will notify the contracting officer within the 30-day period that additional time is necessary.

- (C) In the event the contractor, the laborers or mechanics to be employed in the classification or their representatives, and the contracting officer do not agree on the proposed classification and wage rate (including the amount designated for fringe benefits, where appropriate), the contracting officer shall refer the questions, including the views of all interested parties and the recommendation of the contracting officer, to the Administrator for determination. The Administrator, or an authorized representative, will issue a determination within 30 days of receipt and so advise the contracting officer or will notify the contracting officer within the 30-day period that additional time is necessary.
- (D) The wage rate (including fringe benefits where appropriate) determined pursuant to paragraphs (a)(1)(ii) (B) or (C) of this section, shall be paid to all

workers performing work in the classification under this contract from the first day on which work is performed in the classification.

- (iii) Whenever the minimum wage rate prescribed in the contract for a class of laborers or mechanics includes a fringe benefit which is not expressed as an hourly rate, the contractor shall either pay the benefit as stated in the wage determination or shall pay another bona fide fringe benefit or an hourly cash equivalent thereof.
- (iv) If the contractor does not make payments to a trustee or other third person, the contractor may consider as part of the wages of any laborer or mechanic the amount of any costs reasonably anticipated in providing bona fide fringe benefits under a plan or program, Provided, That the Secretary of Labor has found, upon the written request of the contractor, that the applicable standards of the Davis-Bacon Act have been met. The Secretary of Labor may require the contractor to set aside in a separate account assets for the meeting of obligations under the plan or program.
- (v) (A) The contracting officer shall require that any class of laborers or mechanics which is not listed in the wage determination and which is to be employed under the contract shall be classified in conformance with the wage determination. The contracting officer shall approve an additional classification and wage rate and fringe benefits therefor only when the following criteria have been met:
 - (1) The work to be performed by the classification requested is not performed by a classification in the wage determination; and
 - (2) The classification is utilized in the area by the construction industry; and
 - (3) The proposed wage rate, including any bona fide fringe benefits, bears a reasonable relationship to the wage rates contained in the wage determination.
- (B) If the contractor and the laborers and mechanics to be employed in the classification (if known), or their representatives, and the contracting officer agree on the classification and wage rate (including the amount designated for fringe benefits where appropriate), a report of the action taken shall be sent by the contracting officer to the Administrator of the Wage and Hour Division, Employment Standards Administration, Washington, DC 20210. The Administrator, or an authorized representative, will approve, modify, or disapprove every additional classification action within 30 days of receipt and so advise the contracting officer or will notify the contracting officer within the 30-day period that additional time is necessary.
- (C) In the event the contractor, the laborers or mechanics to be employed in the classification or their representatives, and the contracting officer do not agree on the proposed classification and wage rate (including the amount designated for fringe benefits, where appropriate), the contracting officer shall refer the questions, including the views of all interested parties and the recommendation of the contracting officer, to the Administrator for determination. The Administrator, or an authorized representative, will issue a determination with 30 days of receipt and so advise the contracting officer or will notify the contracting officer within the 30-day period that additional time is necessary.

(D) The wage rate (including fringe benefits where appropriate) determined pursuant to paragraphs (a)(1)(v) (B) or (C) of this section, shall be paid to all workers performing work in the classification under this contract from the first day on which work is performed in the classification.

- (2) **Withholding** - The [*insert name of grantee*] shall upon its own action or upon written request of an authorized representative of the Department of Labor withhold or cause to be withheld from the contractor under this contract or any other Federal contract with the same prime contractor, or any other federally-assisted contract subject to Davis-Bacon prevailing wage requirements, which is held by the same prime contractor, so much of the accrued payments or advances as may be considered necessary to pay laborers and mechanics, including apprentices, trainees, and helpers, employed by the contractor or any subcontractor the full amount of wages required by the contract. In the event of failure to pay any laborer or mechanic, including any apprentice, trainee, or helper, employed or working on the site of the work (or under the United States Housing Act of 1937 or under the Housing Act of 1949 in the construction or development of the project), all or part of the wages required by the contract, the [*insert name of grantee*] may, after written notice to the contractor, sponsor, applicant, or owner, take such action as may be necessary to cause the suspension of any further payment, advance, or guarantee of funds until such violations have ceased.
- (3) **Payrolls and basic records** - (i) Payrolls and basic records relating thereto shall be maintained by the contractor during the course of the work and preserved for a period of three years thereafter for all laborers and mechanics working at the site of the work (or under the United States Housing Act of 1937, or under the Housing Act of 1949, in the construction or development of the project). Such records shall contain the name, address, and social security number of each such worker, his or her correct classification, hourly rates of wages paid (including rates of contributions or costs anticipated for bona fide fringe benefits or cash equivalents thereof of the types described in section 1(b)(2)(B) of the Davis-Bacon Act), daily and weekly number of hours worked, deductions made and actual wages paid. Whenever the Secretary of Labor has found under 29 CFR 5.5(a)(1)(iv) that the wages of any laborer or mechanic include the amount of any costs reasonably anticipated in providing benefits under a plan or program described in section 1(b)(2)(B) of the Davis-Bacon Act, the contractor shall maintain records which show that the commitment to provide such benefits is enforceable, that the plan or program is financially responsible, and that the plan or program has been communicated in writing to the laborers or mechanics affected, and records which show the costs anticipated or the actual cost incurred in providing such benefits. Contractors employing apprentices or trainees under approved programs shall maintain written evidence of the registration of apprenticeship programs and certification of trainee programs, the registration of the apprentices and trainees, and the ratios and wage rates prescribed in the applicable programs.
- (ii) (A) The contractor shall submit weekly for each week in which any contract work is performed a copy of all payrolls to the [*insert name of grantee*] for transmission to the Federal Transit Administration. The payrolls submitted shall set out accurately and completely all of the information required to be maintained under section 5.5(a)(3)(i) of Regulations, 29 CFR part 5. This information may be submitted in any form desired. Optional Form WH-347 is available for this purpose and may be purchased from the Superintendent of Documents (Federal Stock Number 029-005-00014-1), U.S. Government

Printing Office, Washington, DC 20402. The prime contractor is responsible for the submission of copies of payrolls by all subcontractors.

- (B) Each payroll submitted shall be accompanied by a "Statement of Compliance," signed by the contractor or subcontractor or his or her agent who pays or supervises the payment of the persons employed under the contract and shall certify the following:
 - (1) That the payroll for the payroll period contains the information required to be maintained under section 5.5(a)(3)(i) of Regulations, 29 CFR part 5 and that such information is correct and complete;
 - (2) That each laborer or mechanic (including each helper, apprentice, and trainee) employed on the contract during the payroll period has been paid the full weekly wages earned, without rebate, either directly or indirectly, and that no deductions have been made either directly or indirectly from the full wages earned, other than permissible deductions as set forth in Regulations, 29 CFR part 3;
 - (3) That each laborer or mechanic has been paid not less than the applicable wage rates and fringe benefits or cash equivalents for the classification of work performed, as specified in the applicable wage determination incorporated into the contract.
- (C) The weekly submission of a properly executed certification set forth on the reverse side of Optional Form WH-347 shall satisfy the requirement for submission of the "Statement of Compliance" required by paragraph (a)(3)(ii)(B) of this section.
- (D) The falsification of any of the above certifications may subject the contractor or subcontractor to civil or criminal prosecution under section 1001 of title 18 and section 231 of title 31 of the United States Code.
- (iii) The contractor or subcontractor shall make the records required under paragraph (a)(3)(i) of this section available for inspection, copying, or transcription by authorized representatives of the Federal Transit Administration or the Department of Labor, and shall permit such representatives to interview employees during working hours on the job. If the contractor or subcontractor fails to submit the required records or to make them available, the Federal agency may, after written notice to the contractor, sponsor, applicant, or owner, take such action as may be necessary to cause the suspension of any further payment, advance, or guarantee of funds. Furthermore, failure to submit the required records upon request or to make such records available may be grounds for debarment action pursuant to 29 CFR 5.12.
- (4) **Apprentices and trainees** - (i) Apprentices - Apprentices will be permitted to work at less than the predetermined rate for the work they performed when they are employed pursuant to and individually registered in a bona fide apprenticeship program registered with the U.S. Department of Labor, Employment and Training Administration, Bureau of Apprenticeship and Training, or with a State Apprenticeship Agency recognized by the Bureau, or if a person is employed in his or her first 90 days of probationary employment as an apprentice in such an apprenticeship program, who is not individually registered in the program, but who has been certified by the Bureau of Apprenticeship and Training or a State Apprenticeship Agency (where appropriate) to be eligible for probationary

employment as an apprentice. The allowable ratio of apprentices to journeymen on the job site in any craft classification shall not be greater than the ratio permitted to the contractor as to the entire work force under the registered program. Any worker listed on a payroll at an apprentice wage rate, who is not registered or otherwise employed as stated above, shall be paid not less than the applicable wage rate on the wage determination for the classification of work actually performed. In addition, any apprentice performing work on the job site in excess of the ratio permitted under the registered program shall be paid not less than the applicable wage rate on the wage determination for the work actually performed. Where a contractor is performing construction on a project in a locality other than that in which its program is registered, the ratios and wage rates (expressed in percentages of the journeyman's hourly rate) specified in the contractor's or subcontractor's registered program shall be observed. Every apprentice must be paid at not less than the rate specified in the registered program for the apprentice's level of progress, expressed as a percentage of the journeymen hourly rate specified in the applicable wage determination. Apprentices shall be paid fringe benefits in accordance with the provisions of the apprenticeship program. If the apprenticeship program does not specify fringe benefits, apprentices must be paid the full amount of fringe benefits listed on the wage determination for the applicable classification. If the Administrator of the Wage and Hour Division of the U.S. Department of Labor determines that a different practice prevails for the applicable apprentice classification, fringes shall be paid in accordance with that determination. In the event the Bureau of Apprenticeship and Training, or a State Apprenticeship Agency recognized by the Bureau, withdraws approval of an apprenticeship program, the contractor will no longer be permitted to utilize apprentices at less than the applicable predetermined rate for the work performed until an acceptable program is approved.

- (ii) Trainees - Except as provided in 29 CFR 5.16, trainees will not be permitted to work at less than the predetermined rate for the work performed unless they are employed pursuant to and individually registered in a program which has received prior approval, evidenced by formal certification by the U.S. Department of Labor, Employment and Training Administration. The ratio of trainees to journeymen on the job site shall not be greater than permitted under the plan approved by the Employment and Training Administration. Every trainee must be paid at not less than the rate specified in the approved program for the trainee's level of progress, expressed as a percentage of the journeyman hourly rate specified in the applicable wage determination. Trainees shall be paid fringe benefits in accordance with the provisions of the trainee program. If the trainee program does not mention fringe benefits, trainees shall be paid the full amount of fringe benefits listed on the wage determination unless the Administrator of the Wage and Hour Division determines that there is an apprenticeship program associated with the corresponding journeyman wage rate on the wage determination which provides for less than full fringe benefits for apprentices. Any employee listed on the payroll at a trainee rate who is not registered and participating in a training plan approved by the Employment and Training Administration shall be paid not less than the applicable wage rate on the wage determination for the classification of work actually performed. In addition, any trainee performing work on the job site in excess of the ratio permitted under the registered program shall be paid not less than the applicable wage rate on the wage determination for the work actually performed. In the event the Employment and Training Administration withdraws approval of a training program, the contractor will no longer be permitted to utilize trainees at less

than the applicable predetermined rate for the work performed until an acceptable program is approved.

- (iii) Equal employment opportunity - The utilization of apprentices, trainees and journeymen under this part shall be in conformity with the equal employment opportunity requirements of Executive Order 11246, as amended, and 29 CFR part 30.
- (5) **Compliance with Copeland Act requirements** - The contractor shall comply with the requirements of 29 CFR part 3, which are incorporated by reference in this contract.
- (6) **Subcontracts** - The contractor or subcontractor shall insert in any subcontracts the clauses contained in 29 CFR 5.5(a)(1) through (10) and such other clauses as the Federal Transit Administration may by appropriate instructions require, and also a clause requiring the subcontractors to include these clauses in any lower tier subcontracts. The prime contractor shall be responsible for the compliance by any subcontractor or lower tier subcontractor with all the contract clauses in 29 CFR 5.5.
- (7) **Contract termination: debarment** - A breach of the contract clauses in 29 CFR 5.5 may be grounds for termination of the contract, and for debarment as a contractor and a subcontractor as provided in 29 CFR 5.12.
- (8) **Compliance with Davis-Bacon and Related Act requirements** - All rulings and interpretations of the Davis-Bacon and Related Acts contained in 29 CFR parts 1, 3, and 5 are herein incorporated by reference in this contract.
- (9) **Disputes concerning labor standards** - Disputes arising out of the labor standards provisions of this contract shall not be subject to the general disputes clause of this contract. Such disputes shall be resolved in accordance with the procedures of the Department of Labor set forth in 29 CFR parts 5, 6, and 7. Disputes within the meaning of this clause include disputes between the contractor (or any of its subcontractors) and the contracting agency, the U.S. Department of Labor, or the employees or their representatives.
- (10) **Certification of eligibility** - (i) By entering into this contract, the contractor certifies that neither it (nor he or she) nor any person or firm who has an interest in the contractor's firm is a person or firm ineligible to be awarded Government contracts by virtue of section 3(a) of the Davis-Bacon Act or 29 CFR 5.12(a)(1).
 - (ii) No part of this contract shall be subcontracted to any person or firm ineligible for award of a Government contract by virtue of section 3(a) of the Davis-Bacon Act or 29 CFR 5.12(a)(1).
 - (iii) The penalty for making false statements is prescribed in the U.S. Criminal Code, 18 U.S.C. 1001.

14. **CONTRACT WORK HOURS AND SAFETY STANDARDS ACT**

Background and Application

The Contract Work Hours and Safety Standards Act is codified at 40 USC 3701, *et seq.* The Act applies to grantee contracts and subcontracts "financed at least in part by loans or grants from ... the [Federal] Government." 40 USC 3701(b)(1)(B)(iii) and (b)(2), 29 CFR 5.2(h), 49 CFR 18.36(i)(6). Although the original Act required its application in any construction contract over \$2,000 or non-construction contract to which the Act applied over \$2,500 (and

language to that effect is still found in 49 CFR 18.36(i)(6)), the Act no longer applies to any “contract in an amount that is not greater than \$100,000.” 40 USC 3701(b)(3) (A)(iii).

The Act applies to construction contracts and, in very limited circumstances, non-construction projects that employ “laborers or mechanics on a public work.” These non-construction applications do not generally apply to transit procurements because transit procurements (to include rail cars and buses) are deemed “commercial items.” 40 USC 3707, 41 USC 403 (12). A grantee that contemplates entering into a contract to procure a developmental or unique item should consult counsel to determine if the Act applies to that procurement and that additional language required by 29 CFR 5.5(c) must be added to the basic clause below.

The clause language is drawn directly from 29 CFR 5.5(b) and any deviation from the model clause below should be coordinated with counsel to ensure the Act’s requirements are satisfied.

Clause Language

Contract Work Hours and Safety Standards

- (1) **Overtime requirements** - No contractor or subcontractor contracting for any part of the contract work which may require or involve the employment of laborers or mechanics shall require or permit any such laborer or mechanic in any workweek in which he or she is employed on such work to work in excess of forty hours in such workweek unless such laborer or mechanic receives compensation at a rate not less than one and one-half times the basic rate of pay for all hours worked in excess of forty hours in such workweek.
- (2) **Violation; liability for unpaid wages; liquidated damages** - In the event of any violation of the clause set forth in paragraph (1) of this section the contractor and any subcontractor responsible therefor shall be liable for the unpaid wages. In addition, such contractor and subcontractor shall be liable to the United States for liquidated damages. Such liquidated damages shall be computed with respect to each individual laborer or mechanic, including watchmen and guards, employed in violation of the clause set forth in paragraph (1) of this section, in the sum of \$10 for each calendar day on which such individual was required or permitted to work in excess of the standard workweek of forty hours without payment of the overtime wages required by the clause set forth in paragraph (1) of this section.
- (3) **Withholding for unpaid wages and liquidated damages** - The (*write in the name of the grantee*) shall upon its own action or upon written request of an authorized representative of the Department of Labor withhold or cause to be withheld, from any moneys payable on account of work performed by the contractor or subcontractor under any such contract or any other Federal contract with the same prime contractor, or any other federally-assisted contract subject to the Contract Work Hours and Safety Standards Act, which is held by the same prime contractor, such sums as may be determined to be necessary to satisfy any liabilities of such contractor or subcontractor for unpaid wages and liquidated damages as provided in the clause set forth in paragraph (2) of this section.
- (4) **Subcontracts** - The contractor or subcontractor shall insert in any subcontracts the clauses set forth in paragraphs (1) through (4) of this section and also a clause requiring the subcontractors to include these clauses in any lower tier subcontracts. The prime

contractor shall be responsible for compliance by any subcontractor or lower tier subcontractor with the clauses set forth in paragraphs (1) through (4) of this section.

15. DRUG AND ALCOHOL TESTING

(49 U.S.C. §5331, 49 CFR Parts 653 and 654)

Applicability to Contracts

The Drug and Alcohol testing provisions apply to Operational Service Contracts.

Flow Down Requirements

Anyone who performs a safety-sensitive function for the recipient or subrecipient is required to comply with 49 CFR 653 and 654, with certain exceptions for contracts involving maintenance services. Maintenance contractors for non-urbanized area formula program grantees are not subject to the rules. Also, the rules do not apply to maintenance subcontractors.

Model Clause/Language

Introduction

FTA's drug and alcohol rules, 49 CFR 653 and 654, respectively, are unique among the regulations issued by FTA. First, they require recipients to ensure that any entity performing a safety-sensitive function on the recipient's behalf (usually subrecipients and/or contractors) implement a complex drug and alcohol testing program that complies with Parts 653 and 654. Second, the rules condition the receipt of certain kinds of FTA funding on the recipient's compliance with the rules; thus, the recipient is not in compliance with the rules unless every entity that performs a safety-sensitive function on the recipient's behalf is in compliance with the rules. Third, the rules do not specify how a recipient ensures that its subrecipients and/or contractors comply with them.

How a recipient does so depends on several factors, including whether the contractor is covered independently by the drug and alcohol rules of another Department of Transportation operating administration, the nature of the relationship that the recipient has with the contractor, and the financial resources available to the recipient to oversee the contractor's drug and alcohol testing program. In short, there are a variety of ways a recipient can ensure that its subrecipients and contractors comply with the rules.

Therefore, FTA has developed three model contract provisions for recipients to use "as is" or to modify to fit their particular situations.

Explanation of Model Contract Clauses

Under Option 1, the recipient ensures the contractor's compliance with the rules by requiring the contractor to participate in a drug and alcohol program administered by the recipient. The advantages of doing this are obvious: the recipient maintains total control over its compliance with 49 CFR 653 and 654. The disadvantage is that the recipient, which may

not directly employ any safety-sensitive employees, has to implement a complex testing program. Therefore, this may be a practical option only for those recipients which have a testing program for their employees, and can add the contractor's safety-sensitive employees to that program.

Under Option 2, the recipient relies on the contractor to implement a drug and alcohol testing program that complies with 49 CFR 653 and 654, but retains the ability to monitor the contractor's testing program; thus, the recipient has less control over its compliance with the drug and alcohol testing rules than it does under option 1. The advantage of this approach is that it places the responsibility for complying with the rules on the entity that is actually performing the safety-sensitive function. Moreover, it reserves to the recipient the power to ensure that the contractor complies with the program. The disadvantage of Option 2 is that without adequate monitoring of the contractor's program, the recipient may find itself out of compliance with the rules.

Under option 3, the recipient specifies some or all of the specific features of a contractor's drug and alcohol compliance program. Thus, it requires the recipient to decide what it wants to do and how it wants to do it. The advantage of this option is that the recipient has more control over the contractor's drug and alcohol testing program, yet it is not actually administering the testing program. The disadvantage is that the recipient has to specify and understand clearly what it wants to do and why.

Drug and Alcohol Testing

Option 1

The contractor agrees to:

(a) participate in (grantee's or recipient's) drug and alcohol program established in compliance with 49 CFR 653 and 654.

Drug and Alcohol Testing

Option 2

The contractor agrees to establish and implement a drug and alcohol testing program that complies with 49 CFR Parts 653 and 654, produce any documentation necessary to establish its compliance with Parts 653 and 654, and permit any authorized representative of the United States Department of Transportation or its operating administrations, the State Oversight Agency of (name of State), or the (insert name of grantee), to inspect the facilities and records associated with the implementation of the drug and alcohol testing program as required under 49 CFR Parts 653 and 654 and review the testing process. The contractor agrees further to certify annually its compliance with Parts 653 and 654 before (insert date) and to submit the Management Information System (MIS) reports before (insert date before March 15) to (insert title and address of person responsible for receiving information). To certify compliance the contractor shall use the "Substance Abuse Certifications" in the "Annual List of Certifications and Assurances for Federal Transit Administration Grants and Cooperative Agreements," which is published annually in the Federal Register.

Drug and Alcohol Testing

Option 3

The contractor agrees to establish and implement a drug and alcohol testing program that complies with 49 CFR Parts 653 and 654, produce any documentation necessary to establish its compliance with Parts 653 and 654, and permit any authorized representative of the United States Department of Transportation or its operating administrations, the State

Oversight Agency of (name of State), or the (insert name of grantee), to inspect the facilities and records associated with the implementation of the drug and alcohol testing program as required under 49 CFR Parts 653 and 654 and review the testing process. The contractor agrees further to certify annually its compliance with Parts 653 and 654 before (insert date) and to submit the Management Information System (MIS) reports before (insert date before March 15) to (insert title and address of person responsible for receiving information). To certify compliance the contractor shall use the "Substance Abuse Certifications" in the "Annual List of Certifications and Assurances for Federal Transit Administration Grants and Cooperative Agreements," which is published annually in the Federal Register. The Contractor agrees further to [Select a, b, or c] (a) submit before (insert date or upon request) a copy of the Policy Statement developed to implement its drug and alcohol testing program; OR (b) adopt (insert title of the Policy Statement the recipient wishes the contractor to use) as its policy statement as required under 49 CFR 653 and 654; OR (c) submit for review and approval before (insert date or upon request) a copy of its Policy Statement developed to implement its drug and alcohol testing program. In addition, the contractor agrees to: (to be determined by the recipient, but may address areas such as: the selection of the certified laboratory, substance abuse professional, or Medical Review Officer, or the use of a consortium).

16. DISADVANTAGED BUSINESS ENTERPRISE (DBE)

(49 CFR Part 26)

Background and Applicability

The newest version on the Department of Transportation's Disadvantaged Business Enterprise (DBE) program became effective July 16, 2003. The rule provides guidance to grantees on the use of overall and contract goals, requirement to include DBE provisions in subcontracts, evaluating DBE participation where specific contract goals have been set, reporting requirements, and replacement of DBE subcontractors. Additionally, the DBE program dictates payment terms and conditions (including limitations on retainage) applicable to all subcontractors regardless of whether they are DBE firms or not.

The DBE program applies to all DOT-assisted contracting activities. A formal clause such as that below must be included in all contracts above the micro-purchase level. The requirements of clause subsection b flow down to subcontracts.

A substantial change to the payment provisions in this newest version of Part 26 concerns retainage (see section 26.29). Grantee choices concerning retainage should be reflected in the language choices in clause subsection d.

Clause Language

The following clause language is suggested, not mandatory. It incorporates the payment terms and conditions applicable to all subcontractors based in Part 26 as well as those related only to DBE subcontractors. The suggested language allows for the options available to grantees concerning retainage, specific contract goals, and evaluation of DBE subcontracting participation when specific contract goals have been established.

Disadvantaged Business Enterprises

- a. This contract is subject to the requirements of Title 49, Code of Federal Regulations, Part 26, *Participation by Disadvantaged Business Enterprises in Department of Transportation Financial Assistance Programs*. The national goal for participation of Disadvantaged Business Enterprises (DBE) is 10%. The agency's overall goal for DBE participation is 5 %. A contract goal of 0% DBE participation has been established for this procurement.

- b. The contractor shall not discriminate on the basis of race, color, national origin, or sex in the performance of this contract. The contractor shall carry out applicable requirements of 49 CFR *Part 26* in the award and administration of this DOT-assisted contract. Failure by the contractor to carry out these requirements is a material breach of this contract, which may result in the termination of this contract or such other remedy as the City of Greeley deems appropriate. Each subcontract the contractor signs with a subcontractor must include the assurance in this paragraph (see 49 CFR 26.13(b)).

The successful bidder/offeror will be required to report its DBE participation obtained through race-neutral means throughout the period of performance.

- c. The contractor is required to pay its subcontractors performing work related to this contract for satisfactory performance of that work no later than 30 days after the contractor's receipt of payment for that work from the City of Fort Collins. In addition, the contractor may not hold retainage from its subcontractors and is required to return any retainage payments to those subcontractors within 30 days after the subcontractor's work related to this contract is satisfactorily completed.
- d. The contractor must promptly notify the City of Fort Collins whenever a DBE subcontractor performing work related to this contract is terminated or fails to complete its work, and must make good faith efforts to engage another DBE subcontractor to perform at least the same *amount* of work. The contractor may not terminate any DBE subcontractor and perform that work through its own forces or those of an affiliate without prior written consent of the City of Fort Collins.

17. RECYCLED PRODUCTS

(42 U.S.C. 6962, 40 CFR Part 247, Executive Order 12873)

Applicability to Contracts

The Recycled Products requirements apply to all contracts for items designated by the EPA, when the purchaser or contractor procures \$10,000 or more of one of these items during the fiscal year, or has procured \$10,000 or more of such items in the previous fiscal year, using Federal funds. New requirements for "recovered materials" will become effective May 1, 1996. These new regulations apply to all procurement actions involving items designated by the EPA, where the procuring agency purchases \$10,000 or more of one of these items in a fiscal year, or when the cost of such items purchased during the previous fiscal year was \$10,000.

Flow Down

These requirements flow down to all to all contractor and subcontractor tiers.

Model Clause/Language

No specific clause is mandated, but FTA has developed the following language.

Recovered Materials - The contractor agrees to comply with all the requirements of Section 6002 of the Resource Conservation and Recovery Act (RCRA), as amended (42 U.S.C. 6962), including but not limited to the regulatory provisions of 40 CFR Part 247, and Executive Order 12873, as they apply to the procurement of the items designated in Subpart B of 40 CFR Part 247.

18. ADA ACCESS

Accessibility. Facilities to be used in public transportation service must comply with 42 U.S.C. Sections 12101 *et seq.* and DOT regulations, "Transportation Services for

Individuals with Disabilities (ADA),” 49 CFR Part 37; and Joint ATBCB/DOT regulations, “Americans with Disabilities (ADA) Accessibility Specifications for Transportation Vehicles,” 36 CFR Part 1192 and 49 CFR Part 38. Notably, DOT incorporated by reference the ATBCB’s “Americans with Disabilities Act Accessibility Guidelines” (ADAAG), revised July 2004, which include accessibility guidelines for buildings and facilities, and are incorporated into Appendix A to 49 CFR Part 37. DOT also added specific provisions to Appendix A modifying the ADAAG, with the result that buildings and facilities must comply with both the ADAAG and amendments thereto in Appendix A to 49 CFR Part 37.

19. COMPLIANCE WITH FEDERAL LAW, REGULATIONS, AND EXECUTIVE ORDERS

The recipient and its contractors are required to comply with all Federal laws, regulations, and executive orders.

This an acknowledgement that FEMA financial assistance will be used to fund all or a portion of the contract. The contractor will comply with all applicable Federal law, regulations, executive orders, FEMA policies, procedures, and directives.”

20. NON-USE OF DHS SEAL, LOGO, AND FLAGS

Recipients must obtain permission prior to using the DHS seal(s), logos, crests, or reproductions of flags or likenesses of DHS agency officials. See DHS Standard Terms and Conditions: Version 8.1 (2018).

The contractor shall not use the DHS seal(s), logos, crests, or reproductions of flags or likeness of DHS agency officials without specific FEMA pre-approval.

21. PROCUREMENT OF RECOVERED MATERIALS

A non-Federal entity that is a state agency or agency of a political subdivision of a state and its contractors must comply with Section 6002 of the Solid Waste Disposal Act, as amended by the Resource Conservation and Recovery Act. See 2 C.F.R. Part 200, Appendix II, ¶ J; and 2 C.F.R. § 200.322.

In the performance of this contract, the Contractor shall make maximum use of products containing recovered materials that are EPA-designated items unless the product cannot be acquired—

- Competitively within a timeframe providing for compliance with the contract performance schedule;
- Meeting contract performance requirements; or
- At a reasonable price.

Information about this requirement, along with the list of EPA-designated items, is available at EPA’s Comprehensive Procurement Guidelines web site, <https://www.epa.gov/smm/comprehensive-procurement-guideline-cpg-program>.

The Contractor also agrees to comply with all other applicable requirements of Section 6002 of the Solid Waste Disposal Act.

22. BID PROTEST PROCEDURES

The City of Greeley has a protest procedure, covering any phase of solicitation or award, including but not limited to specification or award. The protest procedures are available from the Purchasing Department, City of Greeley, 1001 9th Avenue, Greeley, CO. 80631. You may also request a copy of the procedures by emailing: Purchasing@greeleygov.com or calling 970-350-9792.