

# Addendum #2

## Final Addendum

### Capital Project Committee



#### Project Information

Project Name:	Centerplace Turn Lane Improvements
Bid Number:	FL20-01-002
Date:	December 27, 2019
Project Manager:	Brian Ward

#### Addendum Items

<b>Item 1:</b>	It has been confirmed that the project shall need a SWMP, which has been included with this addendum. A state construction storm water permit and a land grading permit shall be required for the project. The Contractor shall include the costs for all applicable permits into the "Permits" bid item. The contractor shall assign a Qualified Stormwater Manager, at the start of construction, to execute and monitor the SWMP.
<b>Item 2:</b>	An updated Special Provision for bid item 3310 has been included with this addendum. When in conflict, this updated special provision shall supersede any previous versions of this bid item special provisions.
<b>Item 3:</b>	Bid item 7000 "F/A Minor Contract Revisions" shall be in the amount of \$25,000.
<b>Item 4:</b>	Bid Item 7000 "F/A Erosion Control" shall be in the amount of \$5,000. The contractor shall be responsible for all costs associated with executing and monitoring the project specific SWMP and these costs shall be included in the 1010 "Mobilization" bid item. This Force Account item shall only be used in the event of unknown changes or additions to erosion control for the project.
<b>Item 5:</b>	The landscaping wall shall not be required to be designed or stamped by a professional engineer.
<b>Item 6:</b>	The bus shelter and bike racks shall be relocated by Lamar at no cost to the contractor. The contractor is responsible for coordinating with Lamar for the removal and installation of the items. (Steven Cecil with Lamar - scecil@lamar.com)
<b>Item 7:</b>	The contractor shall coordinate with the City of Greeley for temporary relocation of the bus stop. The contractor shall notify the City three (3) business days prior to the closure of the bus stop. (Darren Davis with the City - Darren.Davis@Greeleygov.com - Cc the City PM)

**Stormwater Management Plan  
For  
Centerplace Turn Lane Improvements Project –  
City of Greeley**

December 20<sup>th</sup>, 2019

Prepared for:

**City of Greeley Public Works**  
1001 9<sup>th</sup> Ave  
Greeley, CO 80631

Prepared by:

**JR Engineering, LLC**  
7200 South Alton Way. Suite C400  
Centennial, Colorado 80112  
(303) 740-9393  
Contact: Elijah Farney, PE

JR Project No. 39722.02

## TABLE OF CONTENTS

1.0	QUALIFIED STORMWATER MANAGER .....	1
2.0	SPILL PREVENTION AND RESPONSE PLAN.....	1
2.1.	Spill Management.....	1
3.0	MATERIALS HANDLING.....	2
4.0	POTENTIAL POLLUTANTS.....	6
4.1.	Potential Pollution Sources .....	8
4.2.	Non-Storm Water Components of Discharge .....	8
4.3.	Reporting of Hazardous Releases.....	9
5.0	IMPLEMENTATION OF CONTROL MEASURES .....	9
5.1.	Controls Overview .....	9
5.2.	Erosion and Sediment Controls .....	10
5.2.1.	Structural Practices (See drawings for locations).....	10
5.2.2.	Non-Structural Practices (See drawings for locations).....	13
5.3.	Other Controls (See drawings for location).....	14
6.0	SITE DESCRIPTION .....	14
6.1.	Introduction.....	14
6.2.	Project Description .....	14
6.3.	Construction activities and Schedule .....	15
6.4.	Soil and Surface Conditions .....	16
6.5.	Site Conditions.....	17
6.6.	Wetlands and Receiving Waters.....	17
7.0	SITE MAP .....	18
8.0	FINAL STABILIZATION AND LONG TERM STORMWATER MANAGEMENT .....	20
9.0	INSPECTION REPORTS .....	21
9.1.	Inspection and Maintenance Overview.....	21
9.2.	Inspection Reports.....	24
10.0	CONCLUSION .....	25
11.0	REFERENCES.....	26

## **APPENDICES**

### Appendix A – Figures

Figure 1-Vicinity Map

Figure 2-Soil Map

Figure 3-Flood Insurance Rate Map

### Appendix B – Standards and Specification for Selected BMPs

### Appendix C – Spill Prevention, Control, and Countermeasure Plan (SPCC)

### Appendix D – Erosion and Sediment Control Inspection Form

### Appendix E – Stormwater Management Plan



## 1.0 QUALIFIED STORMWATER MANAGER

Implementation and management of the environmental aspects of this project under this SWMP are the responsibilities of the General Contractor. The General Contractor shall ensure the all contractors providing services on the project have access to a copy of the SWMP and appropriate training regarding storm water pollution prevention. The General Contractor, Building Contractor, Utility Installations Contractor, Grading Contractor and all other contractors and subcontractors shall be familiar with the SWMP and their responsibilities on the plan.

In the event of any violation of the State or Federal Clean Water Act rules and/or regulations that results in fines, penalties, or expenses to the Owner, the Contractor shall reimburse the owner for all such fines, penalties or expenses.

Prior to clearing and grubbing the General Contractor shall post the site information. The post containing the site information shall be near the construction entrance and all papers shall be in a weatherproof container.

The qualified Stormwater Manager on this project shall be:

TBD

## 2.0 SPILL PREVENTION AND RESPONSE PLAN

### 2.1. Spill Management

Construction site supervisors should create and adopt a spill control plan that includes measures and procedures to stop the source of the spill, contain the spill, clean up, and disposal of contaminated materials. Key personnel shall be identified and trained to be responsible for spill prevention and control. The following measures would be appropriate for a spill prevention and response plan:

- Store and handle materials to prevent spills.
  - Tightly seal containers.
  - Make sure all containers are clearly labeled.
  - Stack containers neatly and securely
  - Where possible, store containers on pallets in a covered area.
- Reduce stormwater contact if there is a spill.
  - Have cleanup procedures clearly posted.
  - Have cleanup materials readily available.
  - Contain any liquid.

- Stop the source of the spill.
- Cover spill with absorbent material.
- Dispose of contaminated materials according to manufacturer's instructions or according to State or local requirements.
- Identify personnel responsible for responding to a spill of toxic or hazardous materials.
  - Provide personnel spill response training.
  - Post names of spill response personnel.
- Keep the spill area well ventilated.
- If necessary, use a private firm that specializes in cleanup.
- Concrete trucks shall use the designated concrete washout areas so that concrete wash water does not discharge from the site, and never into a storm drain or stream.

## 2.2. Reporting

Additionally, records of spills, leaks, or overflows that result in the discharge of pollutants must be documented and maintained. Information such as the time and date, weather conditions, response procedure taken, response personnel involved, reasons for the spill, etc., shall be recorded for all occurrences in the SWMP and on the map. An inspection form located in Appendix D has been provided for the filing of these records.

Spill Categories are as follows:

### Minor Spills

- Any event that involves 5 gallons or more and or involves the following
- Less than the reportable quantity
- Stays within the permitted area
- Does not threaten any stormwater conveyances
- Notify the City of Greeley immediately

### Significant Spills

- Reportable Quantity (SARA title III List of Lists, available from EPA for reportable quantity)
- Any amount leaving the permitted area
- And/or threatens any water conveyances.
- Notify CDPHE and the City of Greeley within 24 hours and provide written documentation within 5 days of a spill/and or event

### Hazardous Spills

- Any substance requiring a MSDS response.
- Procedure shall include but limited to:

- Secure the area
- Provide first aid
- Notify emergency response personnel
- Notify CDPHE and the City of Greeley within 24 hours and provide written documentation within 5 days of discovering a spill and or event.

Some spills may need to be reported to the Division of Water Quality and the City of Greeley immediately. Specifically significant spills are: a release of any chemical, oil, petroleum product, sewage, etc., which may enter waters of the State of Colorado (which include surface water, ground water and dry gullies or storm sewers leading to surface water), any spill that exceeds the reportable quantity, and any amount that leaves the permitted area must be reported (See Appendix C). **The Division's toll-free 24-hour environmental emergency spill reporting line is 1-877-518-5608.** Written documentation to both the CDPHE (Division) and City of Greeley of significant spills should be provided within 5 days.

A spill prevention, control, and countermeasure plan is provided in Appendix C.

### **3.0 MATERIALS HANDLING**

Pollution prevention measures shall be utilized to prevent construction materials with the potential of polluting stormwater, such as those listed above, from coming in contact with runoff. Measures include good housekeeping and proper disposal of construction and demolition debris, equipment fuel, lubricants, paints and solvents, asphalt, concrete, topsoil and other materials, as well as controls which prevent sediments from being tracked off-site by construction vehicles, and proper control of any non-stormwater flows on-site.

As previously stated, Best Management Practices (BMPs) are schedules of activities, prohibitions of practices, maintenance procedures, and other management practices to prevent or reduce pollution of public waters. BMPs also control site runoff, spillage or leaks, sludge or waste disposal, or drainage from raw material storage. With regard to construction, these may include structural controls and nonstructural practices that are designed to prevent pollutants from entering water or direct the flow of water away from potential sources of pollution.

For construction sites, there are three main types of BMPs, those that prevent erosion and sediment transport, others that prevent pollutants from construction materials from mixing with stormwater, and those that trap pollutants before they can be discharged. BMPs for most common construction materials and wastes with the greatest potential for adversely affecting stormwater quality are as follows:

BMPs for Construction Waste:

- Select a designated waste collection area onsite.
- Provide an adequate number of containers with lids or covers that can be placed over the containers prior to rainfall.
- When possible, locate containers in a covered area.
- Arrange for waste collection before containers overflow.
- If a container does spill, provide cleanup immediately.
- Plan for additional containers and more frequent pickups during the demolition phase of construction.
- Make sure that construction waste is collected, removed, and disposed of only at authorized disposal areas.
- Check with local solid waste management agency for specific guidance.
- Trash, debris and spoils shall be properly contained at the END of EACH day.

BMPs for Hazardous Wastes Disposal:

- Check with local waste management authorities to determine what the requirements are for disposing of hazardous materials.
- Use the entire product before disposing of the container.
- Do not remove the original product label from the container. It contains important information.
- Do not mix products together unless specifically recommended by the manufacturer.
- The correct disposal of these products varies with the product utilized. Follow the manufacturers recommended method, which is often found on the label.

BMPs for Hazardous Products management:

- Have equipment to contain and clean up spills of hazardous materials in the vicinity of where these materials are to be stored or used.
- Contain and clean up spills immediately after they occur. Contact State or Local solid waste regulatory agency concerning information and procedures necessary to treat or dispose of contaminated soils.
- Keep materials in a dry covered area and elevated from the ground.

BMPs for residual Concrete disposal:

- Emptying or wash out of excess concrete may be allowed on site. Excess concrete and wash water should be disposed of in a manner that prevents contact between these materials and stormwater discharges from the site.
- Residual concrete shall be discharged in specifically designated dike areas, which have been prepared to prevent contact between the concrete and/or washout and stormwater discharged from the site and/or ground water.

- The hardened residue from the dike areas shall be disposed of in the same manner as other non-hazardous construction waste materials or may be broken up and utilized as deemed appropriate by the contractor.
- The use of the washout area shall be temporary (less than one year).
- Washing of trucks and masonry equipment is to be performed only at a designated concrete washout. No burying of wastes.

BMPs for Sanitary/Septic Wastes:

- Sanitary or septic wastes that are generated onsite should be treated or disposed of in accordance with State or local requirements.
- If self-contained, temporary facilities are utilized, the domestic waste haulers should be contracted to regularly remove the sanitary and septic wastes and to maintain the facilities in good working order.
- Any facilities to be connected to a sanitary sewer system should be properly hooked to the sanitary sewer system to prevent illicit discharges.
- Untreated, raw sewage should never be discharged or buried onsite.
- Contact local government and State regulatory agencies to ensure the compliance with State or local requirements.
- If sewage is being discharged to the sanitary sewer, the local treatment works authority should be contacted.

BMPs for pesticides:

- Store pesticides in a dry covered area and elevate above the ground.
- Provide curbs or dikes to contain possible spills.
- Have measures on site to contain and clean up spills.
- Strictly follow recommended application rates and recommended application methods.
- Only a Certified Applicator shall use pesticides.

BMPs for petroleum products:

- Fueling operations shall occur in a designated area.
- Have equipment to contain and clean up petroleum spills in fuel storage areas or on board maintenance and fueling vehicles.
- Where possible, store petroleum products and fuel vehicles in covered areas and construct dikes to contain spills.
- Contain and clean up spills immediately.
- Use preventive maintenance for onsite equipment such as checking for and fixing gas and oil leaks in construction vehicles on a regular basis.
- Follow proper procedure for the handling and application of asphaltic substances.
- Oversee all filling operations.
- Fueling equipment and area shall be fenced and locked to prevent vandalism.

BMPs for Fertilizers/Detergents:

- Limit the application of fertilizers to the minimum area and minimum recommended amounts.
- Reduce exposure of nutrients to stormwater runoff by working the fertilizer deep into the soil.
- Apply fertilizer more frequently, but at lower application rates.
- Hydro seeding, where lime and fertilizers are applied to the ground surface in one application should be limited, where possible.
- Limit the use of detergents onsite: wash water containing detergents should not be discharged to the storm system.
- Implement good erosion and sediment control to help reduce the amount of fertilizers that can leave the site as well as sediments.
- Fertilizers and detergents shall be stored in dry and covered area and elevated above the ground.
- Berming shall be provided around the storage area to avoid contact with stormwater runoff.

#### **4.0 POTENTIAL POLLUTANTS**

During construction of the new facilities, onsite storm water may be contaminated with pollutants such as soil sediments, the washing of exposed aggregate and concrete mix trucks, equipment fueling, washing and maintenance operations, accidental material or chemical spills, pavement washing and/or sealing and other related activities. Specific pollution components and their solutions are listed below:

- All disturbed and stored soils – All exposed soils will be stabilized upon completion of construction within the vicinity. Silt fence will be utilized to contain sediment deposited by runoff until project completion. Silt fence or similar barrier should be installed as needed around long-term stockpiles (30 days+), as well as Vehicle Tracking Control should be installed at access points to minimize sediment from leaving the area.
- Vehicle tracking of sediments – If sediment is tracked onto the street, a reasonable attempt will be made to clean up any large deposits as soon as possible and if necessary, a street sweeper may be used.
- Management of contaminated soils – Appropriate measures will be taken to clean up the cause of the contaminated soil. All contaminated soils must be disposed of in an appropriate manner off-site.
- Loading and unloading operations – Should a spill occur during a loading or unloading operation it shall be cleaned up immediately and the on-site personnel should be contacted.
- Outdoor storage activities – Materials with potential for contamination of stormwater runoff will be stored so as to prevent/minimize the presence of toxic materials, and designated accordingly. The areas on the construction site used

for material storage that are exposed to precipitation shall be inspected for evidence of, or the potential for, pollutants entering the drainage system.

- Vehicle and equipment maintenance and fueling – All designated fueling and maintenance areas shall be located a minimum of 100 feet from all drainage courses whenever possible. If the fueling area is located on porous soil, the area shall be covered with a non-porous lining to prevent soil contamination and any spillage shall be cleaned up immediately.
- Significant dust or particulate generating processes – dust-reducing measures will be taken during construction until appropriate seeding and mulching can be placed.
- Routine maintenance activities involving fertilizers, pesticides, detergents, fuels, solvents, oils, etc. – Oil, grease, coolants, etc. that leak onto the soil or impervious surface should be cleaned up as soon as possible and on-site personnel should be contacted as well.
- On-site waste management practices (waste piles, liquid wastes, dumpsters, etc.) – Dumpsters will be utilized as needed to remove trash from the site. Any waste material found on-site or generated by construction will be disposed of in a manner as to not cause pollutants in storm water discharges. In the event that waste is to be stored on-site, it shall be in an area located a minimum of 100 feet from all drainage courses whenever possible. Whenever waste is not stored in a non-porous container, it shall be in an area enclosed by a 12-inch high compacted earthen ridge. If the enclosed waste area is located on porous soil, the area shall be covered with a non-porous lining to prevent soil contamination. Whenever precipitation is predicted, the waste shall be covered with a non-porous cover, anchored on all sides to prevent its removal by wind, in order to prevent precipitation from leaching out potential pollutants from the waste.
- Concrete truck/equipment washing, including the concrete truck chute and associated fixtures and equipment – concrete truck/equipment washing will take place in the designated concrete wash-out area which shall be placed a minimum of 100' from any drainage/water sources. The area shall limit the travel of wash water from the area. The area shall be cleaned up of all washed cement on an “as necessary” basis.
- Dedicated asphalt and concrete batch plants – It is assumed a batch plant will not be utilized. If at such time a batch plant is used it will be the responsibility of the contractor to update the SWMP report and plans in addition to receiving/obtaining all necessary permits.
- Non-industrial waste sources such as worker trash and portable toilets – All portable toilets should be kept a minimum of 50 feet from a storm drain inlet and secured to the ground.

#### **4.1. Potential Pollution Sources**

It is anticipated that this construction project will not utilize any abnormal or atypical hazardous materials. The construction site will operate much like other typical roadway construction projects. The following materials or substances are expected to be present onsite during construction:

Concrete/Additives/Wastes	Cleaning solvents
Detergents	Petroleum based products
Paints/Solvents	Pesticides
Acids	Fertilizers
Solid and construction wastes	Sanitary wastes
Soil stabilization additives	

Activities on the site that may have an impact on stormwater include the following:

- Equipment and/or vehicle washing
- Fertilizers, chemicals, or other material storage
- Vehicle maintenance or fueling
- Waste incineration, treatment, storage or disposal
- Off-site vehicle tracking
- Loading/unloading areas
- Concrete truck washout

As construction progresses, specific areas shall be designated for vehicle maintenance and refueling, material and waste storage, construction equipment staging, and bathroom facilities. Management measures and procedures for these facilities are discussed later in the plan. The contractor shall mark the location of these facilities on the "Erosion and Sediment Control Plan" Appendix E of this report.

#### **4.2. Non-Storm Water Components of Discharge**

This plan does not cover construction dewatering. Pumping or draining groundwater that has infiltrated into an excavation requires a General Permit for Construction Dewatering Discharges, regardless of the size of the project.

No materials shall be discharged in quantities that will have an adverse effect on the receiving waters. The measures listed below will be implemented to achieve these objectives.

- Proper and lawful disposal of all waste materials.



- Control any spills and leaks that may occur and clean up (mitigate).
- Use of designated areas for equipment repair and cleaning.
- Careful application of irrigation water.

### **4.3. Reporting of Hazardous Releases**

All potential pollutants used during construction other than sediment, will be handled and disposed of in a manner that does not contaminate storm water.

All materials used during construction, which have the potential to impact storm water quality will be stored, managed, used and disposed of in a manner that minimizes the potential for releases to the environment, especially storm water.

Any oil, hazardous substance, or hazardous waste release that exceeds the reportable quantity must be reported as outlined in “Reporting Chemical Spills and Releases in Colorado” (Appendix C). The General Contractor must also modify the SWMP within 14 calendar days of knowledge of the release to: provide a description of the release, the circumstances leading to the release and the date of the release. The plan must also be reviewed to ensure the prevention of future releases and appropriate responses to such releases.

## **5.0 IMPLEMENTATION OF CONTROL MEASURES**

### **5.1. Controls Overview**

During construction, several controls and measures shall be implemented under the direction of the General Contractor to prevent offsite discharge of contaminated storm water. Controls for this project include erosion, sedimentation, stabilization, and other BMPs. Specifications and engineering drawings for the selected BMPs can be found in Appendix B which contains a sample list of erosion and sediment control BMPs from the Urban Drainage and Flood Control District - Urban Storm Drainage Criteria Manual Volume 3.

The contractor shall comply with the attached plans and guidelines as a minimum. Field conditions and unforeseen circumstances will dictate modifications to or additions to this Storm Water Management Plan. Where storm water pollution potential exists, appropriate preventative measures (BMPs) must be utilized and documented, whether such measures are identified in this report or not. Location of stabilized staging area and concrete washout area shall be determined by General Contractor.

## **5.2. Erosion and Sediment Controls**

The objective of erosion control is to limit the amount of erosion occurring on disturbed areas until the site is stabilized. The objective of sediment control is to capture the soil that has been eroded before it leaves the construction site. Despite the use of both erosion and sediment control measures, it is recognized that some sediment could remain in runoff leaving the construction site. This should be minimized to the maximum extent practicable.

During all phases of construction the General Contractor shall in the event of a substantial rainfall event, provide storm water collection and conveyance systems to collect and direct sediment contaminated water to temporary sediment traps as needed to prevent offsite discharge of sediment laden storm water. Construction shall occur in phases as much as practicable to avoid unnecessarily exposing vegetated areas of the site. Clean storm water, generated from stabilized and undisturbed portions of the site, will be collected and conveyed to stabilize discharges whenever necessary to avoid contact with disturbed portions of the site. All conveyance and collection systems will be constructed consistent with State, Federal, and local BMP requirements.

The BMPs scheduled for use during the construction of this site can be divided into Structural and Non-Structural Practices. Section 5.2.1 of this report discusses the proposed structural BMPs to be utilized. Section 5.2.2 discusses the non-structural practices. More detail for each BMP can be found in Appendix B.

### **5.2.1. Structural Practices (See drawings for locations)**

Structural BMPs are structural site management practices that will minimize erosion and sediment transport. Such practices may include straw bales, silt fences, earth dikes, drainage swales, sediment traps and basins, inlet protections, outlet protection, etc. The goal of structural BMPs on this project is to protect areas downstream of the site from turbid water, sediment, oils and other contaminants, which may mobilize during storm water flows. The structural BMPs that may be utilized on the subject site are depicted in the Stormwater Management Plans and are described in more detail as follows:

Construction Fence:

- Restricts site access to designated entrances and exits.
- Delineates construction site boundaries.

Silt Fence:

- A temporary vertical barrier of filter fabric attached to and supported by posts and entrenched into the ground.
- Utilized to intercept sediment from disturbed areas during construction operations.
- Used to filter shallow sheet flow.
- Typically used along the toe of fills, in transition areas between cut and fills, and adjacent to streams.
- Generally installed prior to or immediately following land-disturbance activity.
- Shall be inspected periodically and after each rain or snowfall event and repaired when necessary. Sediment shall be removed from behind the fence when it accumulates to one-half the exposed fabric height. Sediments removed must be properly disposed.
- Utilized as a temporary feature.

Inlet Protection:

- A barrier across or around a storm drain drop inlet, a curb inlet, or a culvert inlet.
- Utilized to intercept and filter sediment-laden runoff and prevent it from entering storm drainage systems.
- Not to be utilized in place of a sediment-trapping device. Used as a secondary control device.
- Do not use where ponded water might flow onto the roadway.
- Blocking of the inlet should not be watertight.
- Generally installed prior to land-disturbance activity on existing inlets and immediately after the construction of new inlets.
- Shall be inspected periodically and after each rain or snowfall event and repaired when necessary. Accumulated sediment shall be removed and properly disposed.
- Utilized as a temporary feature.

Rock Socks:

- Cylindrical, gravel wrapped in wire mesh or geotextile to trap sediment from storm water runoff that flows onto roadways.
- Used in perimeter control or inlet protection.
- Shall be inspected periodically for damage and repair or replace if necessary.
- Utilized as a temporary feature until upstream stabilization is complete.

Grading Techniques:

- Soil surface roughening, terracing and rounding at tops of cuts, transitions and roadway ditches to facilitate plant establishment and minimize erosion.

- Utilized to temporarily stabilize disturbed areas and protect from wind and water erosion immediately after grading activities have ceased.
- Used as a temporary practice during construction.
- Inspection and maintenance must be provided periodically and after each rain or snowfall event that causes runoff to ensure roughened state is maintained.
- Rills developed should be filled and the area re-graded immediately.

Concrete Washout:

- Designating and managing a specific area as a concrete washout area.
- Three approaches: excavation of a pit in the ground, use of an above ground storage area, or use of prefabricated haul-away concrete washout containers.
- Used as a temporary practice during construction.
- Should not be located in area where shallow groundwater may be present.
- When unlined pits are used for washout, the soil must have adequate buffering capacity to result in protection of groundwater standards due to high pH concern.

Stabilized Staging Area:

- Designated area where equipment, vehicles, stockpiles, waste bins, and other construction equipment are stored.
- Appropriate space, stabilized surface (paved or covered), perimeter control (silt fence), a stabilized construction entrance/exit are all needed.
- Used as a temporary practice during construction.

Vehicle Tracking Control / Construction Entrance:

- A temporary stabilized layer of aggregate underlined with geotextile or gravel located where traffic enters or exits the construction site.
- The structure shall be constructed prior to any construction activity and maintained daily.
- Stone shall be added and repairs performed as conditions require.
- When mud is present and not easily removed by a tracking pad, tire washing should be implemented as needed. Tire washing operations should occur near the construction exit on a stabilized stone pad. Implementation of a tire washing area should include provisions for collecting wash water and directing it to an onsite pond.

Erosion control measures are the responsibility of the General Contractor to inspect and maintain. Any existing erosion control devices that are removed in order to complete the construction of the utilities shall be replaced immediately following the construction that required its removal unless directed otherwise by the construction plans.

### **5.2.2. Non-Structural Practices (See drawings for locations)**

Non-Structural BMPs are both interim and permanent stabilization practices. Such practices may include temporary seeding, permanent seeding, mulching, geotextiles, sod stabilization, vegetative buffer strips, tree protection, preservation of mature vegetation, etc. The non-structural BMPs that may be utilized on the subject site are described in more detail as follows:

#### Temporary and Permanent Seeding:

- Soil preparation, seeding, mulch tackifier and/or mulching shall be required for all disturbed areas that are not surfaced.
- Exposed soils, which are not part of the active grading and/or construction activity, shall be stabilized.
- Seeded areas shall be inspected frequently. If the seeded areas fail to establish, provide adequate ground coverage. If seeded areas are disturbed, the area should be re-seeded.

#### Mulching:

- Application of plant residues to the soil surface. Typical mulching material includes certified weed free hay or straw, certified under the Colorado Department of Agriculture Weed Free Forage Certification Program as regulated by the Weed Free Forage Act, Title 35, Article 27.5, CRS and wood cellulose fiber.
- Utilized in combination with mulch tackifier for temporary erosion control (i.e., incomplete slopes, detour slopes, stockpiles).
- Utilized in combination with mulch tackifier for temporary erosion control on slopes when seeding is not allowed due to seasonal constraints.
- Used to cover permanent or temporary seed areas. Hydromulch shall not be done in the presence of free surface water.
- Inspect frequently and reapply mulching in areas where the mulching has been loosened or removed. Mulch tackifier must be applied with additional applications of mulching.

#### Maintain Existing Vegetation:

- Existing vegetation should be preserved where possible to prevent the migration of sediment.
- Should be inspected regularly.
- Establish and maintain buffers.
- Areas beginning to show signs of erosion or soil transport may require additional emergency BMPs.

### **5.3. Other Controls (See drawings for location)**

Control Practices for Wind Erosion:

- Wind erosion shall be controlled on the site by sprinkling and other appropriate means.
- Stockpiles and disturbed earth throughout the site may be watered regularly or as designated by the General Contractor to eliminate/control wind erosion.

## **6.0 SITE DESCRIPTION**

### **6.1. Introduction**

The following Storm Water Management Plan (SWMP) has been prepared for use during the Centerplace Turn Lane improvements project. The project is located in a part of Section 14, Township 5 North, Range 66 West of the 6<sup>th</sup> Principal Meridian, in the City of Greeley in the state of Colorado. The overall development site is Centerplace Drive between 47<sup>th</sup> and 44<sup>th</sup> Avenues. This plan describes recommended procedures and methods to assist the General Contractor and sub-contractors in complying with the provisions of the Colorado Water Quality Control Act and the Federal Water Pollution Control Act.

This plan serves as a consolidated document for information on water quality protection for the subject site and areas immediately adjacent. It should also be noted that this plan is a living document that will need to be updated and maintained throughout the construction process. The intent of this plan is to provide the contractor a tool to consolidate records, logs, permits, applications, etc. as well as guidance on water quality protection. The plan incorporates elements that can be found in the contract plans and specifications as well as the following:

- Urban Drainage and Flood Control District Urban Storm Drainage Criteria Manual Volume 3 – Best Management Practices
- Colorado Department of Transportation Erosion Control and Stormwater Quality Guide

### **6.2. Project Description**

The City of Greeley plans to add turn lanes at the following locations:

- Eastbound Right (EBR) at Centerplace Drive and 46<sup>th</sup> Avenue
- Westbound Right (WBR) at Centerplace Drive and 46<sup>th</sup> Avenue
- EBR at Centerplace Drive and 44<sup>th</sup> Avenue

Estimated total acreage of the construction site is 0.89 Acres. Expected acreage to be disturbed by clearing, excavation, grading, or any other construction activities are 0.89 Acres with 0.13 Acres of landscaping. Currently, the site is a developed urban

community with little vegetative ground cover. The project involves restoring all disturbed ground to original state with 100% of the site being paved.

### **6.3. Construction activities and Schedule**

The Contractor will be responsible for implementing and maintaining the stormwater management plan (SWMP) measures described in the document and the accompanying design drawings. The Contractor may designate these tasks to certain subcontractors as he sees fit, but the ultimate responsibility for implementing these controls and their proper function at each phase of the project remains with the Contractor. The order of major activities will be as follows:

1. Clearing and grubbing necessary for perimeter controls
2. Install perimeter controls, including silt fence around the site
3. Install additional BMP's, as outlined in SWMP
4. Clearing of existing structures and excavation
5. Grading
6. Utility Installation
7. Curb and gutter
8. Street paving. Installation of permanent BMP's
9. Removal of temporary BMP's

#### **Phase Construction Activity and BMP Implementation**

The project will follow standard construction sequences for construction, i.e., clearing and grubbing, over excavation, overlot grading, utility installation, curb and gutter, and street paving.

Three phases were considered for erosion/sediment control and construction activities:

- Initial Phase
- Interim Phase
- Final Phase

#### **Initial Phase**

Upon authorization to proceed and prior to full mobilization of the earth work operation initial SWMP BMP measures will be installed. These measures include:

- Silt/construction fence will be installed as perimeter control for areas where the existing topography slopes off site and to delineate the site perimeter and locations within the site where access is restricted and other areas of the site that should not be disturbed.
- Curb socks and inlet protection will be installed in the curb and around the existing inlets to reduce sediment loading to storm sewer inlets along Centerplace Drive.
- Rock socks will be installed along the water flow path to control sediment build up and protect against erosion potential.
- The contractor shall clearly identify topsoil stockpile locations.

### **Interim Phase**

Upon completion of the initial phase of stabilization, the contractor may proceed with earthwork operations. This phase of construction will include demolition of existing street, structures, grading, and utility installation/relocation. Some of the BMPs measures installed with initial phase will remain in place through this interim phase, i.e., curb socks, inlet protection and perimeter controls. Additional BMPs during this phase will include:

- Stabilized staging area is proposed at an off-site location and will be the designated area where construction equipment and vehicles, waste bins and other construction-related materials are stored. The contractor office trailer may also be located in this area.
- A concrete washout area will be installed near the construction site at an off-site location.
- Inlet protection measures will be installed at new inlets locations to reduce sediment loading to storm sewer. All the stub-outs that are not used shall be plugged.
- Areas where grading operations are complete will be improved/landscape for final stabilization.

### **Final Phase**

During the final construction stages of the street improvements the contractor shall begin final stabilization of the site. The final phase includes construction of street improvements including curb and gutter and paving. Additional BMP measures for the final phase will include:

- Landscaping will be used to stabilize areas at final grade. Effective landscaping includes preparation of a seedbed, selection of appropriate plantings/sod, proper planting techniques, and protection of any seeded areas with mulch.

## **6.4. Soil and Surface Conditions**

Based on data from the USDA Soil Conservation Service's "Web Soil Survey", the soils found on site are Otero sandy loam and Vona loamy sand part of hydrologic group A; and Olney fine sandy loam part of hydrologic group B. Typical characteristics of soils in hydrologic group A are having low runoff potential and high infiltration rates even when thoroughly wetted. They consist chiefly of deep, well to excessively drained sands or gravels and have a high rate of water transmission. Typical characteristics of soils in hydrologic group B are a moderate infiltration rate when thoroughly wetted and consist chiefly of moderately deep or deep, moderately well drained or well drained soils with moderately fine to moderately coarse textures. These soils have a moderate rate of water transmission as well.



The existing site is developed and is comprised of sandy loam soil typical of Weld county area. Generally, the site drains in a northeasterly direction.

#### **6.5. Site Conditions**

Attached at the end of the this report are a series of drawings that describe the proposed site conditions, as well as the locations of the erosion control Best Management Practices (BMPs). The Storm Water Management Plan depicts the anticipated drainage patterns after major grading activities and the anticipated locations for BMPs such as silt fence, inlet protection, and rock socks. Stabilized staging areas and concrete wash out areas will be located at an off-site location approved by the City of Greeley.

It has been assumed that the majority of the surrounding areas will remain in their present state during the construction of this project.

#### **6.6. Wetlands and Receiving Waters**

Storm runoff drains into an onsite detention pond that releases water into a storm drain in Centerplace Drive. The storm drain runs east and then north along 38<sup>th</sup> Avenue to the Greeley West Detention Pond located about 1.1 miles northeast from the site.

## 7.0 SITE MAP

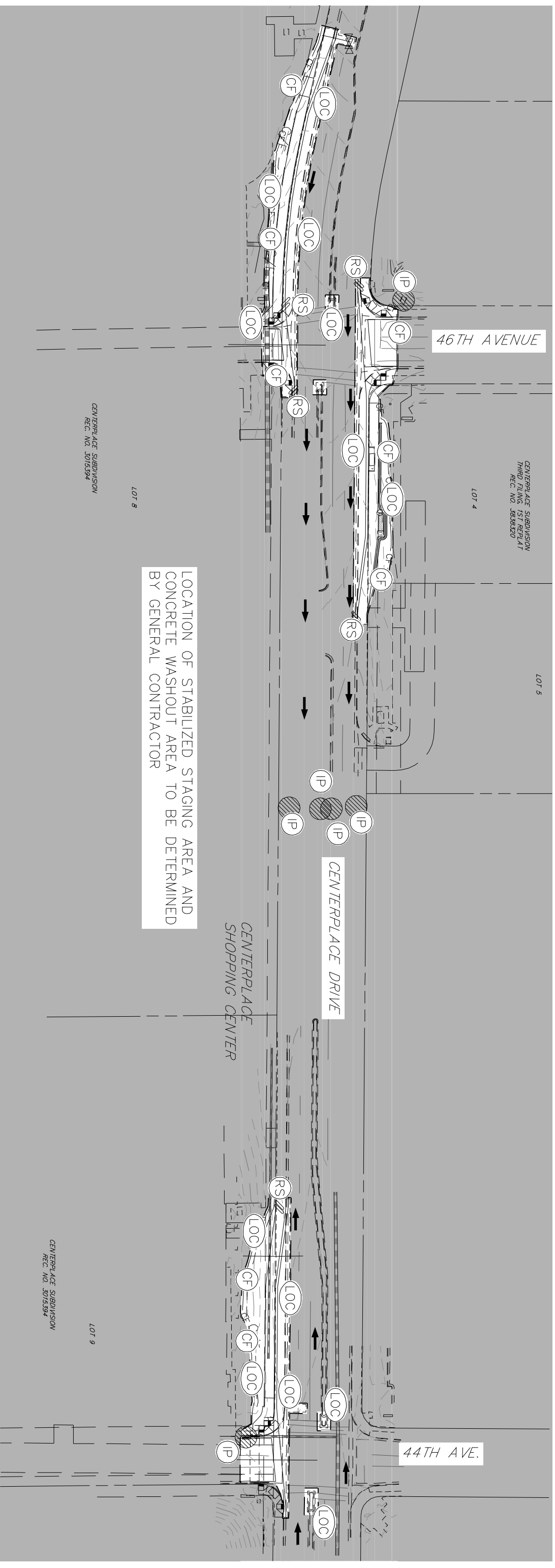

# LEGEND

- EXISTING STORM SEWER
- EXISTING CURB & GUTTER
- LIMITS OF CONSTRUCTION
- CONSTRUCTION FENCE
- SILT FENCE
- DRAINAGE DIRECTION
- PROPOSED CONTOURS

- INLET PROTECTION
- ROCK SOCK
- PERMANENT LANDSCAPING

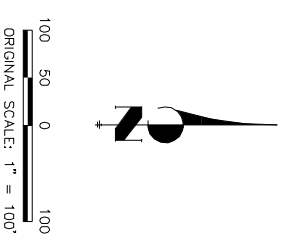

SITE MAP – SWMP  
 CENTERPLACE TURN LANE IMPROVEMENTS  
 JOB NO. 39722.02  
 12/20/19  
 SHEET 1 OF 1

## **8.0 FINAL STABILIZATION AND LONG TERM STORMWATER MANAGEMENT**

The final phasing of the project involves construction of street improvements including curb and gutter and paving. The contractor shall begin final stabilization of the site. The final phase Additional BMP measures for the final phase will include:

- Landscaping will be used to stabilize areas at final grade. Effective landscaping includes preparation of a seedbed, selection of appropriate plantings/sod, proper planting techniques, and protection of any seeded areas with mulch.

Permanent stabilization will be achieved by establishing a vegetative cover on all disturbed areas. The vegetative cover will be as specified on the Landscape Plan. Final stabilization shall be considered complete when all paving and landscaping are completed and the vegetative cover has been established with a density of at least 70 percent of pre-disturbance levels (including shrubs and trees).

In general, spring and fall seeding is encouraged whenever possible. Temporary and permanent seeding shall be completed within 14 days after grading has ceased and left to idle for more than 30 days. Care should be taken to complete seeding activities prior to November 1st for disturbed land intending to remain inactive for the winter months.

Roughening and scarifying disturbed areas is allowed as a temporary stabilization with the following conditions:

- During winter activity
- Intended to be seeded in the spring fall seasons
- Intended to be active within 2-3 months of inactivity (with Stormwater approval)

Management of storm water after completion of construction will be accomplished by utilizing the practices listed below:

- Upon completion of construction, the site shall be inspected to ensure that all equipment, waste materials, and debris have been removed.
- The site will be inspected to make certain that all graded surfaces have been landscaped or seeded with an appropriate ground cover.
- Upon acceptance of final stabilization measures, all temporary BMP's shall be removed and proper function of inlets, drainage ways, or other storm water conveyance elements shall be restored.
- The storm sewer systems, water quality ponds and the detention pond will be returned to full capacity and the outlet structures will be checked to assure they are unclogged and in working order.

The General Contractor shall be responsible for maintaining the storm water controls in good working order including removal measures until the Inactivation Notice is filed with the State. Alternatively, permit responsibilities may be transferred or reassigned by submitting a Notice of Transfer and Acceptance of Terms or a Reassignment of Coverage if control of a portion of the site changes parties. The City of Greeley staff shall document and approve changes regarding inspection frequency and closing of the CDPS permit.

## 9.0 INSPECTION REPORTS

### 9.1 Inspection and Maintenance Overview

The inspector shall be a qualified Stormwater Manager. The inspector shall be:

TBD

A site inspection of all erosion control facilities shall be conducted at least once every seven days and immediately following any significant precipitation or snowmelt event that could cause surface erosion and every 30 days for inactive construction projects. The inspection must determine if there is evidence of, or the potential for, pollutants entering the drainage system, and BMPs should be reviewed to determine if they still meet the design and operational criteria in the SWMP and that they continue to adequately control pollutants at the site. The construction site perimeter, disturbed areas, discharge points and areas used for material storage that are exposed to precipitation shall be inspected for evidence of, or the potential for, pollutants entering the storm drainage system. Erosion and sediment control measures identified in this SWMP and on the construction plans shall be observed to ensure that they are operating correctly. Any other structural BMPs that may require maintenance, such as secondary containment around fuel tanks or the conditions of spill response kits shall also be inspected. Stormwater items to be inspected include the following:

- Condition & failures of structural & non-structural BMPs
- Perimeter and outfall structure
- Evidence of spills, upsets & discharges
- Maintaining accurate SWMP documentation
- Material Handling and storage
- Good Housekeeping
- Site Stabilization
- Meet authorities during inspections
- Update permit disturbed acreage
- Equipment and vehicle storage area

- Maintenance records of equipment, systems & operations

The project site and the adjacent streets impacted by the construction shall be kept neat, clean and free of debris. The control measures and facilities need to be maintained in good working order. Any items that are not functioning properly or are inadequate should be promptly repaired or upgraded. The site shall be inspected by responsible personnel who are familiar with the site. Inspection and monitoring will follow the procedures outlined below:

Minimum Monitoring (Inspection) Requirements:

- Person responsible for conducting inspections must be a qualified stormwater manager.
- Permittees must conduct the first site inspection within seven calendar days of the commencement of construction activities on site. Permittees must conduct site inspections in accordance with one of the following minimum frequencies:
  - At least one inspection every 7 calendar days.
  - At least one inspection every 14 calendar days, PLUS post-storm event inspections conducted within 24 hours after the end of any precipitation or snowmelt event that causes surface erosion.
    - Post-storm inspections may be used to fulfill the 14-day routine inspection requirement.
- Permittees may conduct inspections on either the 7 day or 14 day schedule, and may switch between these schedules as appropriate for the site. The inspection schedule must be noted on the inspection reports, as noted below.
- When site conditions make the required schedule impractical, the permittee may petition the division to grant an alternate inspection schedule. The alternative inspection schedule may not be implemented prior to written approval by the division and incorporation into the plan.
- Permittees must conduct site inspections at least once every 7 calendar days for sites that discharge to a water body designated as an Outstanding Water by the Water Quality Control Commission.
- Post-Storm Inspections at Temporarily Idle Sites - for permittees choosing to combine 14-day inspections and post-storm-event inspections, if no construction activities will occur following a storm event, post-storm event inspections must be conducted prior to re-commencing construction activities, but no later than 72 hours following the storm event. The delay of any post-storm event inspection must be documented in the inspection record. Routine inspections must still be conducted at least every 14 calendar days.
- For Inspections at Completed Sites/Areas:

- When the sites, or portions of a site are awaiting establishment of a vegetative ground cover and final stabilization, the permittee must conduct a site inspection at least once every 30 days.
- Post-storm event inspections are not required.
- This reduced inspection schedule is allowed if all of the following criteria are met:
  - All construction activities resulting in ground disturbance are complete;
  - All activities required for final stabilization, in accordance with the plan, have been completed, with the exception of the application of seed that has not occurred due to seasonal conditions or the necessity for additional seed application to augment previous efforts; and
  - The plan has been amended to locate those areas to be inspected on a reduced schedule.
- Inspections are not required for sites that meet all of the following conditions:
  - Construction activities are temporarily halted,
  - Snow cover exists over the entire site for an extended period, and
  - Melting conditions posing a risk of surface erosion do not exist.
  - When this inspection exclusion is implemented, the following information must be documented in the inspection reports:
    - Dates when snow cover existed;
    - Date when construction activities ceased; and
    - Date melting conditions began.
- The qualified site superintendent familiar with this SWMP/BMP shall perform the inspections.
- The contractor shall certify the site is in compliance with the SWMP/BMP and the permit by:
  - Ensuring that areas contributing significant storm water discharges related to the construction activities have been identified.
  - Evaluating preventive measures required by the SWMP/BMP to insure they are adequate and has been properly implemented.
  - Points of discharge from the site will be inspected to check for signs of pollutant discharge.
  - Certifying the grade elevations and capacity of permanent sedimentation facilities.
  - Determining if additional control measures will need to be implemented.
  - Updating this SWMP if new measures are implemented or existing controls are deleted.

Based on the results of the inspection, the description of potential pollutant sources, and the pollution prevention and control measures that are identified within this

plan shall be revised and modified as appropriate and as soon as practicable after such inspection. Typically corrective action shall commence immediately when a deficiency is observed. SWMP and Map updates shall be completed within 72 hours and BMP repairs shall be completed as soon as practicable. Inspection report follow up information shall include: the date, corrective action taken, and initials of who certified the work.

In addition to the inspections performed at least every 7 days, several daily inspections will be required. Each day when any type of construction activity has taken place onsite, qualified personnel provided by the General Contractor shall:

- Inspect all onsite areas where petroleum products are stored, used or handled for spills and leaks from vehicles and equipment.
- Inspect all onsite locations where vehicle enter or exit the site for evidence of offsite sediment tracking.

## **9.2. Inspection Reports**

The General Contractor shall be responsible for the reporting of all BMP inspections. Permittee or contractor shall produce written inspection records every seven (7) days and after significant precipitation events. All necessary maintenance and repair shall be completed immediately. A report summarizing the scope of each inspection, the name(s) of the personnel performing each inspection, the qualification of personnel performing the inspection, the date(s) of the inspection, major observation relating to the implementation of the SWMP and actions taken shall be made and retained at the site or be readily available at a designated alternate location until the Inactivation Notice has been submitted. All inspection reports shall be submitted to the owner when the Inactivation Notice is filed. A recommended inspection form is included in Appendix D. A separate report shall be made to identify an incident of non-compliance.

The operator shall keep a record of inspections onsite. Uncontrolled releases of mud or muddy water or measurable quantities of sediment found off the site shall be recorded with a brief explanation as to the measures taken to prevent future releases as well as any measure taken to clean up the sediment that has left the site. This record shall also include the following information:

- Inspection Dates
- Name(s) and title(s) of personnel conducting the inspection
- Weather conditions at the time of the inspection
- Phase of construction at the time of the inspection
- Estimated acreage of disturbance at the time of inspection



- Location(s) of discharges of sediment or other pollutants from the site
- Location(s) of control measures needing maintenance
- Location(s) and identification of inadequate control measures
- Location(s) and identification of additional control measures that are needed that were not in place at the time of inspection
- Description of the minimum inspection frequency and any deviations from the minimum inspection schedule
- After adequate corrective action(s) and maintenance have been taken, or where a report does not identify any incidents requiring corrective action or maintenance, the report shall contain the following statement:  
    “I verify that, to the best of my knowledge and belief, all corrective action and maintenance items identified during the inspection are complete, and the site is currently in compliance with the permit.”

All temporary and permanent erosion and sediment control facilities shall be maintained and repaired as needed to assure continued performance of their intended function. Silt Fence and Inlet Protection devices will require periodic maintenance and/or replacement. Sediment Traps and water quality ponds shall be cleaned when accumulated sediments equal approximately one-half of trap storage capacity.

After construction has been completed the inspection reports and the SWMP shall be maintained for three years at:

City of Greeley – Public Works  
1001 9<sup>th</sup> Avenue  
Greeley, CO 80631  
(970) 350-9792

See Appendix D for Stormwater Inspection Report Template Sheet.

## 10.0 CONCLUSION

This Stormwater Management Plan has been prepared in accordance with the criteria and methods described in the “State of Colorado General Permit Application and Stormwater Management Plan Guidance for Stormwater Discharges Associated with Construction Activity.” The drainage system has been designed to comply with Urban Drainage standards and specifications. All temporary and permanent erosion and sediment control BMPs shall be inspected, maintained and repaired by the General Contractor as needed to ensure continued performance of their intended function.

The General Contractor shall remove all temporary erosion and sediment control BMPs after stabilization is achieved or after temporary BMPs are no longer needed. Trapped sediment will be removed by the General Contractor or stabilized onsite. Disturbed soil areas resulting from removal of BMPs or the General Contractor will permanently stabilize vegetation as soon as possible.

## 11.0 REFERENCES

1. CDOT Erosion Control and Stormwater Quality Guide, Colorado Department of Transportation, 2002.
2. Urban Storm Drainage Criteria Manual Volume 3, Urban Drainage Flood Control District, November 2010, rev. October 2019.
3. Soil Survey of Weld County, Colorado, Southern Part, USDA Soil Conservation Service, 1980.
4. Flood Insurance Rate Map (FIRM) for City of Greeley in Weld County, Colorado (Map. No. 08123C1519E, Federal Emergency Management Agency (FEMA,) dated January 20, 2016.
5. Stormwater Fact Sheet – Construction, Colorado Department of Public Health and Environment, revised August 2007.

**APPENDIX A**  
**FIGURES**

**FIGURE 1 – VICINITY MAP**



## VICINITY MAP

VICINITY MAP  
 CENTERPLACE TURN LANE IMPROVEMENTS  
 JOB NO. 39722.02  
 12/20/2019  
 SHEET 1 OF 1



1000' 500' 0 1000'



ORIGINAL SCALE: 1" = 1000'



**J-R ENGINEERING**

A Westrian Company

Centennial 303-740-9393 • Colorado Springs 719-593-2593  
 Fort Collins 970-491-9888 • [www.jrengineering.com](http://www.jrengineering.com)

**FIGURE 2 – SOIL MAP**



Soil Map—Weld County, Colorado, Southern Part

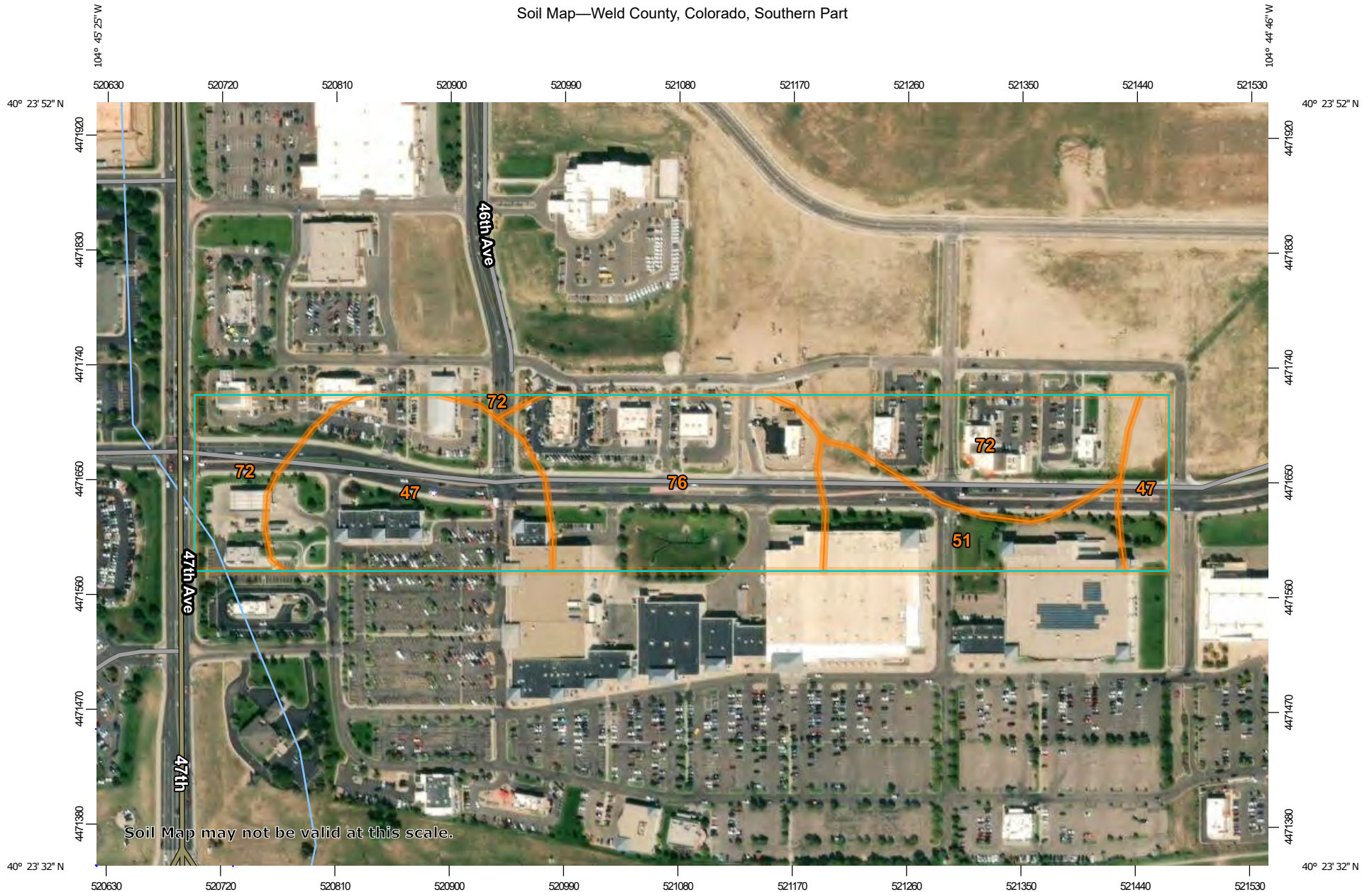

Soil Map may not be valid at this scale.

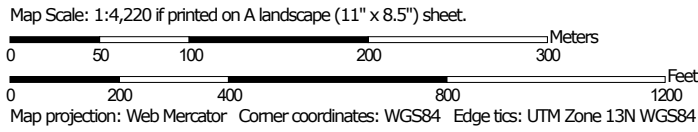

## MAP LEGEND

### Area of Interest (AOI)

 Area of Interest (AOI)

### Soils

 Soil Map Unit Polygons

 Soil Map Unit Lines

 Soil Map Unit Points

### Special Point Features



Blowout



Borrow Pit



Clay Spot



Closed Depression



Gravel Pit



Gravelly Spot



Landfill



Lava Flow



Marsh or swamp



Mine or Quarry



Miscellaneous Water



Perennial Water



Rock Outcrop



Saline Spot



Sandy Spot



Severely Eroded Spot



Sinkhole



Slide or Slip



Sodic Spot



Spoil Area



Stony Spot



Very Stony Spot



Wet Spot



Other



Special Line Features

### Water Features



Streams and Canals

### Transportation



Rails



Interstate Highways



US Routes



Major Roads



Local Roads

### Background



Aerial Photography

## MAP INFORMATION

The soil surveys that comprise your AOI were mapped at 1:24,000.

**Warning:** Soil Map may not be valid at this scale.

Enlargement of maps beyond the scale of mapping can cause misunderstanding of the detail of mapping and accuracy of soil line placement. The maps do not show the small areas of contrasting soils that could have been shown at a more detailed scale.

Please rely on the bar scale on each map sheet for map measurements.

Source of Map: Natural Resources Conservation Service  
 Web Soil Survey URL:  
 Coordinate System: Web Mercator (EPSG:3857)

Maps from the Web Soil Survey are based on the Web Mercator projection, which preserves direction and shape but distorts distance and area. A projection that preserves area, such as the Albers equal-area conic projection, should be used if more accurate calculations of distance or area are required.

This product is generated from the USDA-NRCS certified data as of the version date(s) listed below.

Soil Survey Area: Weld County, Colorado, Southern Part  
 Survey Area Data: Version 18, Sep 13, 2019

Soil map units are labeled (as space allows) for map scales 1:50,000 or larger.

Date(s) aerial images were photographed: Jul 17, 2015—Oct 2, 2017

The orthophoto or other base map on which the soil lines were compiled and digitized probably differs from the background imagery displayed on these maps. As a result, some minor shifting of map unit boundaries may be evident.



## Map Unit Legend

Map Unit Symbol	Map Unit Name	Acres in AOI	Percent of AOI
47	Olney fine sandy loam, 1 to 3 percent slopes	7.8	29.6%
51	Otero sandy loam, 1 to 3 percent slopes	3.6	13.7%
72	Vona loamy sand, 0 to 3 percent slopes	7.4	28.0%
76	Vona sandy loam, 1 to 3 percent slopes	7.5	28.7%
<b>Totals for Area of Interest</b>		<b>26.3</b>	<b>100.0%</b>

**FIGURE 3 – FLOOD INSURANCE RATE MAP**

**\*Panel 1540 contains no special flood hazard areas identified.**



JOINS PANEL 1540

1385000 FT



MAP SCALE 1" = 500'

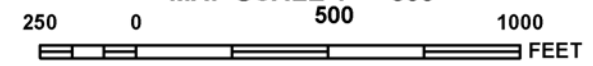

NATIONAL FLOOD INSURANCE PROGRAM

PANEL 1519E

**FIRM**  
**FLOOD INSURANCE RATE MAP**  
**WELD COUNTY,**  
**COLORADO**  
**AND INCORPORATED AREAS**

**PANEL 1519 OF 2250**  
 (SEE MAP INDEX FOR FIRM PANEL LAYOUT)

CONTAINS:

COMMUNITY	NUMBER	PANEL	SUFFIX
EVANS, CITY OF	080182	1519	E
GREELEY, CITY OF	080184	1519	E
WELD COUNTY	080266	1519	E

Notice to User: The **Map Number** shown below should be used when placing map orders; the **Community Number** shown above should be used on insurance applications for the subject community.



**MAP NUMBER**  
**08123C1519E**  
**EFFECTIVE DATE**  
**JANUARY 20, 2016**

Federal Emergency Management Agency

This is an official copy of a portion of the above referenced flood map. It was extracted using F-MIT On-Line. This map does not reflect changes or amendments which may have been made subsequent to the date on the title block. For the latest product information about National Flood Insurance Program flood maps check the FEMA Flood Map Store at [www.msc.fema.gov](http://www.msc.fema.gov)

**APPENDIX B**

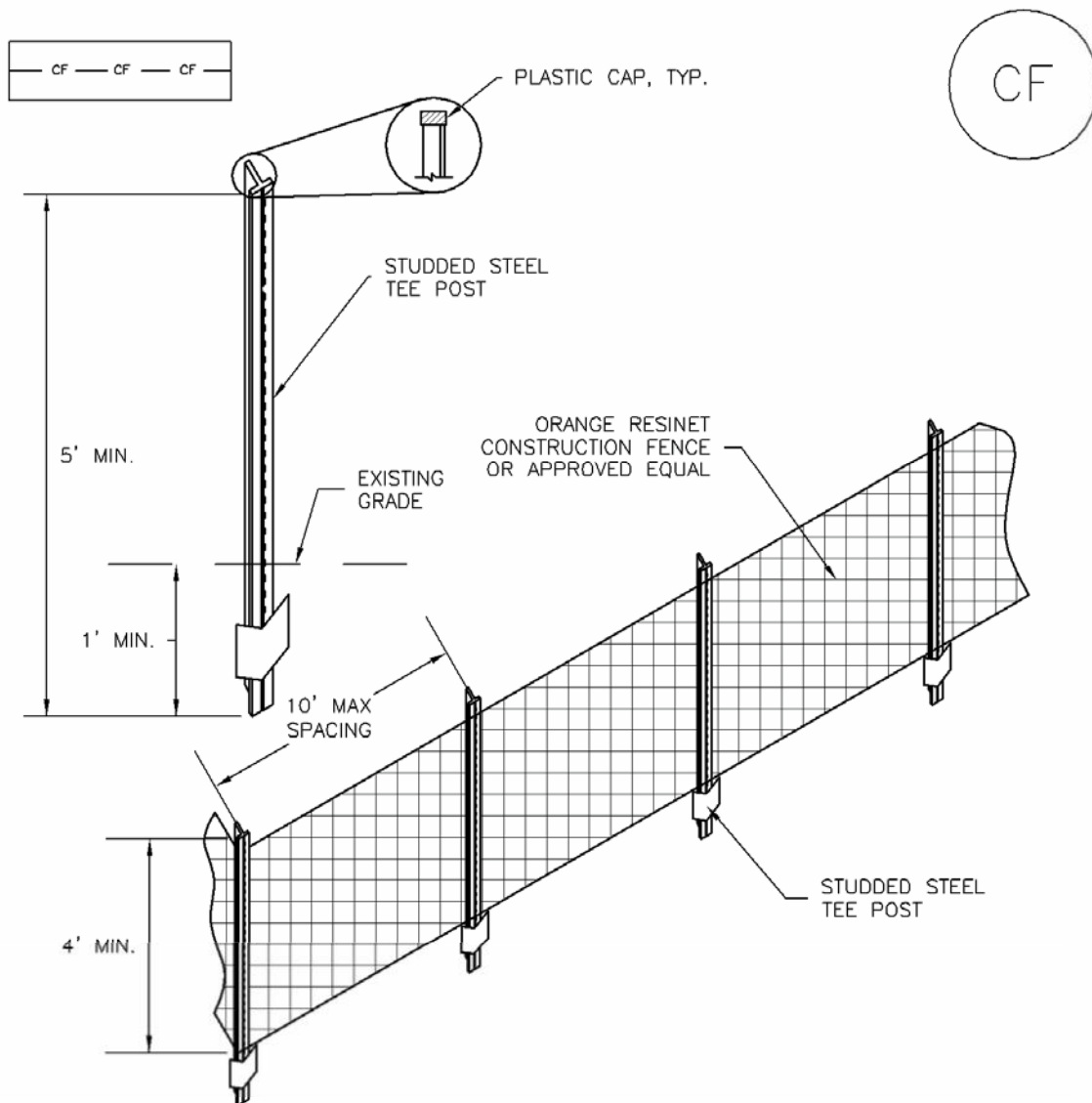

CF-1. PLASTIC MESH CONSTRUCTION FENCE

CONSTRUCTION FENCE INSTALLATION NOTES

1. SEE PLAN VIEW FOR:  
-LOCATION OF CONSTRUCTION FENCE.
2. CONSTRUCTION FENCE SHOWN SHALL BE INSTALLED PRIOR TO ANY LAND DISTURBING ACTIVITIES.
3. CONSTRUCTION FENCE SHALL BE COMPOSED OF ORANGE, CONTRACTOR-GRADE MATERIAL THAT IS AT LEAST 4' HIGH. METAL POSTS SHOULD HAVE A PLASTIC CAP FOR SAFETY.
4. STUDED STEEL TEE POSTS SHALL BE UTILIZED TO SUPPORT THE CONSTRUCTION FENCE. MAXIMUM SPACING FOR STEEL TEE POSTS SHALL BE 10'.
5. CONSTRUCTION FENCE SHALL BE SECURELY FASTENED TO THE TOP, MIDDLE, AND BOTTOM OF EACH POST.

## CONSTRUCTION FENCE MAINTENANCE NOTES

1. INSPECT BMPs EACH WORKDAY, AND MAINTAIN THEM IN EFFECTIVE OPERATING CONDITION. MAINTENANCE OF BMPs SHOULD BE PROACTIVE, NOT REACTIVE. INSPECT BMPs AS SOON AS POSSIBLE (AND ALWAYS WITHIN 24 HOURS) FOLLOWING A STORM THAT CAUSES SURFACE EROSION, AND PERFORM NECESSARY MAINTENANCE.
2. FREQUENT OBSERVATIONS AND MAINTENANCE ARE NECESSARY TO MAINTAIN BMPs IN EFFECTIVE OPERATING CONDITION. INSPECTIONS AND CORRECTIVE MEASURES SHOULD BE DOCUMENTED THOROUGHLY.
3. WHERE BMPs HAVE FAILED, REPAIR OR REPLACEMENT SHOULD BE INITIATED UPON DISCOVERY OF THE FAILURE.
4. CONSTRUCTION FENCE SHALL BE REPAIRED OR REPLACED WHEN THERE ARE SIGNS OF DAMAGE SUCH AS RIPS OR SAGS. CONSTRUCTION FENCE IS TO REMAIN IN PLACE UNTIL THE UPSTREAM DISTURBED AREA IS STABILIZED AND APPROVED BY THE LOCAL JURISDICTION.
5. WHEN CONSTRUCTION FENCES ARE REMOVED, ALL DISTURBED AREAS ASSOCIATED WITH THE INSTALLATION, MAINTENANCE, AND/OR REMOVAL OF THE FENCE SHALL BE COVERED WITH TOPSOIL, SEEDED AND MULCHED, OR OTHERWISE STABILIZED AS APPROVED BY LOCAL JURISDICTION.

NOTE: MANY JURISDICTIONS HAVE BMP DETAILS THAT VARY FROM UDFCD STANDARD DETAILS. CONSULT WITH LOCAL JURISDICTIONS AS TO WHICH DETAIL SHOULD BE USED WHEN DIFFERENCES ARE NOTED.

(DETAIL ADAPTED FROM TOWN OF PARKER, COLORADO, NOT AVAILABLE IN AUTOCAD)

## Description

Concrete waste management involves designating and properly managing a specific area of the construction site as a concrete washout area. A concrete washout area can be created using one of several approaches designed to receive wash water from washing of tools and concrete mixer chutes, liquid concrete waste from dump trucks, mobile batch mixers, or pump trucks. Three basic approaches are available: excavation of a pit in the ground, use of an above ground storage area, or use of prefabricated haul-away concrete washout containers. Surface discharges of concrete washout water from construction sites are prohibited.



**Photograph CWA-1.** Example of concrete washout area. Note gravel tracking pad for access and sign.

## Appropriate Uses

Concrete washout areas must be designated on all sites that will generate concrete wash water or liquid concrete waste from onsite concrete mixing or concrete delivery.

Because pH is a pollutant of concern for washout activities, when unlined pits are used for concrete washout, the soil must have adequate buffering capacity to result in protection of state groundwater standards; otherwise, a liner/containment must be used. The following management practices are recommended to prevent an impact from unlined pits to groundwater:

- The use of the washout site should be temporary (less than 1 year), and
- The washout site should be not be located in an area where shallow groundwater may be present, such as near natural drainages, springs, or wetlands.

## Design and Installation

Concrete washout activities must be conducted in a manner that does not contribute pollutants to surface waters or stormwater runoff. Concrete washout areas may be lined or unlined excavated pits in the ground, commercially manufactured prefabricated washout containers, or aboveground holding areas constructed of berms, sandbags or straw bales with a plastic liner.

Although unlined washout areas may be used, lined pits may be required to protect groundwater under certain conditions.

**Do not locate an unlined washout area within 400 feet of any natural drainage pathway or waterbody or within 1,000 feet of any wells or drinking water sources.** Even for lined concrete washouts, it is advisable to locate the facility away from waterbodies and drainage paths. If site constraints make these

Concrete Washout Area	
Functions	
Erosion Control	No
Sediment Control	No
Site/Material Management	Yes

setbacks infeasible or if highly permeable soils exist in the area, then the pit must be installed with an impermeable liner (16 mil minimum thickness) or surface storage alternatives using prefabricated concrete washout devices or a lined aboveground storage area should be used.

Design details with notes are provided in Detail CWA-1 for pits and CWA-2 for aboveground storage areas. Pre-fabricated concrete washout container information can be obtained from vendors.

## Maintenance and Removal

A key consideration for concrete washout areas is to ensure that adequate signage is in place identifying the location of the washout area. Part of inspecting and maintaining washout areas is ensuring that adequate signage is provided and in good repair and that the washout area is being used, as opposed to washout in non-designated areas of the site.

Remove concrete waste in the washout area, as needed to maintain BMP function (typically when filled to about two-thirds of its capacity). Collect concrete waste and deliver offsite to a designated disposal location.

Upon termination of use of the washout site, accumulated solid waste, including concrete waste and any contaminated soils, must be removed from the site to prevent on-site disposal of solid waste. If the wash water is allowed to evaporate and the concrete hardens, it may be recycled.



**Photograph CWA-2.** Prefabricated concrete washout. Photo courtesy of CDOT.



**Photograph CWA-3.** Earthen concrete washout. Photo courtesy of CDOT.



## Description

Inlet protection consists of permeable barriers installed around an inlet to filter runoff and remove sediment prior to entering a storm drain inlet. Inlet protection can be constructed from rock socks, sediment control logs, silt fence, block and rock socks, or other materials approved by the local jurisdiction. Area inlets can also be protected by over-excavating around the inlet to form a sediment trap.



**Photograph IP-1.** Inlet protection for a curb opening inlet.

## Appropriate Uses

Install protection at storm sewer inlets that are operable during construction. Consider the potential for tracked-out sediment or temporary stockpile areas to contribute sediment to inlets when determining which inlets must be protected. This may include inlets in the general proximity of the construction area, not limited to downgradient inlets. Inlet protection is not a stand-alone BMP and should be used in conjunction with other upgradient BMPs.

## Design and Installation

To function effectively, inlet protection measures must be installed to ensure that flows do not bypass the inlet protection and enter the storm drain without treatment. However, designs must also enable the inlet to function without completely blocking flows into the inlet in a manner that causes localized flooding. When selecting the type of inlet protection, consider factors such as type of inlet (e.g., curb or area, sump or on-grade conditions), traffic, anticipated flows, ability to secure the BMP properly, safety and other site-specific conditions. For example, block and rock socks will be better suited to a curb and gutter along a roadway, as opposed to silt fence or sediment control logs, which cannot be properly secured in a curb and gutter setting, but are effective area inlet protection measures.

Several inlet protection designs are provided in the Design Details. Additionally, a variety of proprietary products are available for inlet protection that may be approved for use by local governments. If proprietary products are used, design details and installation procedures from the manufacturer must be followed. Regardless of the type of inlet protection selected, inlet protection is most effective when combined with other BMPs such as curb socks and check dams. Inlet protection is often the last barrier before runoff enters the storm sewer or receiving water.

Design details with notes are provided for these forms of inlet protection:

- IP-1. Block and Rock Sock Inlet Protection for Sump or On-grade Inlets
- IP-2. Curb (Rock) Socks Upstream of Inlet Protection, On-grade Inlets

<b>Inlet Protection (various forms)</b>	
<b>Functions</b>	
Erosion Control	No
Sediment Control	Yes
Site/Material Management	No

IP-3. Rock Sock Inlet Protection for Sump/Area Inlet

IP-4. Silt Fence Inlet Protection for Sump/Area Inlet

IP-5. Over-excavation Inlet Protection

IP-6. Straw Bale Inlet Protection for Sump/Area Inlet

CIP-1. Culvert Inlet Protection

Proprietary inlet protection devices should be installed in accordance with manufacturer specifications.

More information is provided below on selecting inlet protection for sump and on-grade locations.

### **Inlets Located in a Sump**

When applying inlet protection in sump conditions, it is important that the inlet continue to function during larger runoff events. For curb inlets, the maximum height of the protective barrier should be lower than the top of the curb opening to allow overflow into the inlet during larger storms without excessive localized flooding. If the inlet protection height is greater than the curb elevation, particularly if the filter becomes clogged with sediment, runoff will not enter the inlet and may bypass it, possibly causing localized flooding, public safety issues, and downstream erosion and damage from bypassed flows.

Area inlets located in a sump setting can be protected through the use of silt fence, concrete block and rock socks (on paved surfaces), sediment control logs/straw wattles embedded in the adjacent soil and stacked around the area inlet (on pervious surfaces), over-excavation around the inlet, and proprietary products providing equivalent functions.

### **Inlets Located on a Slope**

For curb and gutter inlets on paved sloping streets, block and rock sock inlet protection is recommended in conjunction with curb socks in the gutter leading to the inlet. For inlets located along unpaved roads, also see the Check Dam Fact Sheet.

## **Maintenance and Removal**

Inspect inlet protection frequently. Inspection and maintenance guidance includes:

- Inspect for tears that can result in sediment directly entering the inlet, as well as result in the contents of the BMP (e.g., gravel) washing into the inlet.
- Check for improper installation resulting in untreated flows bypassing the BMP and directly entering the inlet or bypassing to an unprotected downstream inlet. For example, silt fence that has not been properly trenched around the inlet can result in flows under the silt fence and directly into the inlet.
- Look for displaced BMPs that are no longer protecting the inlet. Displacement may occur following larger storm events that wash away or reposition the inlet protection. Traffic or equipment may also crush or displace the BMP.
- Monitor sediment accumulation upgradient of the inlet protection.

- Remove sediment accumulation from the area upstream of the inlet protection, as needed to maintain BMP effectiveness, typically when it reaches no more than half the storage capacity of the inlet protection. For silt fence, remove sediment when it accumulates to a depth of no more than 6 inches. Remove sediment accumulation from the area upstream of the inlet protection as needed to maintain the functionality of the BMP.
- Proprietary inlet protection devices should be inspected and maintained in accordance with manufacturer specifications. If proprietary inlet insert devices are used, sediment should be removed in a timely manner to prevent devices from breaking and spilling sediment into the storm drain.

Inlet protection must be removed and properly disposed of when the drainage area for the inlet has reached final stabilization.

## Description

A rock sock is constructed of gravel that has been wrapped by wire mesh or a geotextile to form an elongated cylindrical filter. Rock socks are typically used either as a perimeter control or as part of inlet protection. When placed at angles in the curb line, rock socks are typically referred to as curb socks. Rock socks are intended to trap sediment from stormwater runoff that flows onto roadways as a result of construction activities.



**Photograph RS-1.** Rock socks placed at regular intervals in a curb line can help reduce sediment loading to storm sewer inlets. Rock socks can also be used as perimeter controls.

## Appropriate Uses

Rock socks can be used at the perimeter of a disturbed area to control localized sediment loading. A benefit of rock socks as opposed to other perimeter controls is that they do not have to be trenched or staked into the ground; therefore, they are often used on roadway construction projects where paved surfaces are present.

Use rock socks in inlet protection applications when the construction of a roadway is substantially complete and the roadway has been directly connected to a receiving storm system.

## Design and Installation

When rock socks are used as perimeter controls, the maximum recommended tributary drainage area per 100 linear feet of rock socks is approximately 0.25 acres with disturbed slope length of up to 150 feet and a tributary slope gradient no steeper than 3:1. A rock sock design detail and notes are provided in Detail RS-1. Also see the Inlet Protection Fact Sheet for design and installation guidance when rock socks are used for inlet protection and in the curb line.

When placed in the gutter adjacent to a curb, rock socks should protrude no more than two feet from the curb in order for traffic to pass safely. If located in a high traffic area, place construction markers to alert drivers and street maintenance workers of their presence.

## Maintenance and Removal

Rock socks are susceptible to displacement and breaking due to vehicle traffic. Inspect rock socks for damage and repair or replace as necessary. Remove sediment by sweeping or vacuuming as needed to maintain the functionality of the BMP, typically when sediment has accumulated behind the rock sock to one-half of the sock's height.

Once upstream stabilization is complete, rock socks and accumulated sediment should be removed and properly disposed.

Rock Sock	
Functions	
Erosion Control	No
Sediment Control	Yes
Site/Material Management	No

## Description

A silt fence is a woven geotextile fabric attached to wooden posts and trenched into the ground. It is designed as a sediment barrier to intercept sheet flow runoff from disturbed areas.

## Appropriate Uses

A silt fence can be used where runoff is conveyed from a disturbed area as sheet flow. Silt fence is not designed to receive concentrated flow or to be used as a filter fabric. Typical uses include:

- Down slope of a disturbed area to accept sheet flow.
- Along the perimeter of a receiving water such as a stream, pond or wetland.
- At the perimeter of a construction site.



**Photograph SF-1.** Silt fence creates a sediment barrier, forcing sheet flow runoff to evaporate or infiltrate.

## Design and Installation

Silt fence should be installed along the contour of slopes so that it intercepts sheet flow. The maximum recommended tributary drainage area per 100 lineal feet of silt fence, installed along the contour, is approximately 0.25 acres with a disturbed slope length of up to 150 feet and a tributary slope gradient no steeper than 3:1. Longer and steeper slopes require additional measures. This recommendation only applies to silt fence installed along the contour. Silt fence installed for other uses, such as perimeter control, should be installed in a way that will not produce concentrated flows. For example, a "J-hook" installation may be appropriate to force runoff to pond and evaporate or infiltrate in multiple areas rather than concentrate and cause erosive conditions parallel to the silt fence.

See Detail SF-1 for proper silt fence installation, which involves proper trenching, staking, securing the fabric to the stakes, and backfilling the silt fence. Properly installed silt fence should not be easily pulled out by hand and there should be no gaps between the ground and the fabric.

Silt fence must meet the minimum allowable strength requirements, depth of installation requirement, and other specifications in the design details. Improper installation of silt fence is a common reason for silt fence failure; however, when properly installed and used for the appropriate purposes, it can be highly effective.

<b>Silt Fence</b>	
<b>Functions</b>	
Erosion Control	No
Sediment Control	Yes
Site/Material Management	No

## Maintenance and Removal

Inspection of silt fence includes observing the material for tears or holes and checking for slumping fence and undercut areas bypassing flows. Repair of silt fence typically involves replacing the damaged section with a new section. Sediment accumulated behind silt fence should be removed, as needed to maintain BMP effectiveness, typically before it reaches a depth of 6 inches.

Silt fence may be removed when the upstream area has reached final stabilization.



**Photograph SF-2.** When silt fence is not installed along the contour, a "J-hook" installation may be appropriate to ensure that the BMP does not create concentrated flow parallel to the silt fence. Photo courtesy of Tom Gore.



## Description

A stabilized staging area is a clearly designated area where construction equipment and vehicles, stockpiles, waste bins, and other construction-related materials are stored. The contractor office trailer may also be located in this area. Depending on the size of the construction site, more than one staging area may be necessary.



**Photograph SSA-1.** Example of a staging area with a gravel surface to prevent mud tracking and reduce runoff. Photo courtesy of Douglas County.

## Appropriate Uses

Most construction sites will require a staging area, which should be clearly designated in SWMP drawings. The layout of the staging area may vary depending on the type of construction activity. Staging areas located in roadways due to space constraints require special measures to avoid materials being washed into storm inlets.

## Design and Installation

Stabilized staging areas should be completed prior to other construction activities beginning on the site. Major components of a stabilized staging area include:

- Appropriate space to contain storage and provide for loading/unloading operations, as well as parking if necessary.
- A stabilized surface, either paved or covered, with 3-inch diameter aggregate or larger.
- Perimeter controls such as silt fence, sediment control logs, or other measures.
- Construction fencing to prevent unauthorized access to construction materials.
- Provisions for Good Housekeeping practices related to materials storage and disposal, as described in the Good Housekeeping BMP Fact Sheet.
- A stabilized construction entrance/exit, as described in the Vehicle Tracking Control BMP Fact Sheet, to accommodate traffic associated with material delivery and waste disposal vehicles.

Over-sizing the stabilized staging area may result in disturbance of existing vegetation in excess of that required for the project. This increases costs, as well as requirements for long-term stabilization following the construction period. When designing the stabilized staging area, minimize the area of disturbance to the extent practical.

<b>Stabilized Staging Area</b>	
<b>Functions</b>	
Erosion Control	Yes
Sediment Control	Moderate
Site/Material	Yes

**Minimizing Long-Term Stabilization Requirements**

- Utilize off-site parking and restrict vehicle access to the site.
- Use construction mats in lieu of rock when staging is provided in an area that will not be disturbed otherwise.
- Consider use of a bermed contained area for materials and equipment that do not require a stabilized surface.
- Consider phasing of staging areas to avoid disturbance in an area that will not be otherwise disturbed.

See Detail SSA-1 for a typical stabilized staging area and SSA-2 for a stabilized staging area when materials staging in roadways is required.

**Maintenance and Removal**

Maintenance of stabilized staging areas includes maintaining a stable surface cover of gravel, repairing perimeter controls, and following good housekeeping practices.

When construction is complete, debris, unused stockpiles and materials should be recycled or properly disposed. In some cases, this will require disposal of contaminated soil from equipment leaks in an appropriate landfill. Staging areas should then be permanently stabilized with vegetation or other surface cover planned for the development.



## Description

Vehicle tracking controls provide stabilized construction site access where vehicles exit the site onto paved public roads. An effective vehicle tracking control helps remove sediment (mud or dirt) from vehicles, reducing tracking onto the paved surface.



**Photograph VTC-1.** A vehicle tracking control pad constructed with properly sized rock reduces off-site sediment tracking.

## Appropriate Uses

Implement a stabilized construction entrance or vehicle tracking control where frequent heavy vehicle traffic exits the construction site onto a paved roadway. An effective vehicle tracking control is particularly important during the following conditions:

- Wet weather periods when mud is easily tracked off site.
- During dry weather periods where dust is a concern.
- When poorly drained, clayey soils are present on site.

Although wheel washes are not required in designs of vehicle tracking controls, they may be needed at particularly muddy sites.

## Design and Installation

Construct the vehicle tracking control on a level surface. Where feasible, grade the tracking control towards the construction site to reduce off-site runoff. Place signage, as needed, to direct construction vehicles to the designated exit through the vehicle tracking control. There are several different types of stabilized construction entrances including:

**VTC-1. Aggregate Vehicle Tracking Control.** This is a coarse-aggregate surfaced pad underlain by a geotextile. This is the most common vehicle tracking control, and when properly maintained can be effective at removing sediment from vehicle tires.

**VTC-2. Vehicle Tracking Control with Construction Mat or Turf Reinforcement Mat.** This type of control may be appropriate for site access at very small construction sites with low traffic volume over vegetated areas. Although this application does not typically remove sediment from vehicles, it helps protect existing vegetation and provides a stabilized entrance.

Vehicle Tracking Control	
Functions	
Erosion Control	Moderate
Sediment Control	Yes
Site/Material Management	Yes

**VTC-3. Stabilized Construction Entrance/Exit with Wheel Wash.** This is an aggregate pad, similar to VTC-1, but includes equipment for tire washing. The wheel wash equipment may be as simple as hand-held power washing equipment to more advanced proprietary systems. When a wheel wash is provided, it is important to direct wash water to a sediment trap prior to discharge from the site.

Vehicle tracking controls are sometimes installed in combination with a sediment trap to treat runoff.

## Maintenance and Removal

Inspect the area for degradation and replace aggregate or material used for a stabilized entrance/exit as needed. If the area becomes clogged and ponds water, remove and dispose of excess sediment or replace material with a fresh layer of aggregate as necessary.

With aggregate vehicle tracking controls, ensure rock and debris from this area do not enter the public right-of-way.

Remove sediment that is tracked onto the public right of way daily or more frequently as needed. Excess sediment in the roadway indicates that the stabilized construction entrance needs maintenance.

Ensure that drainage ditches at the entrance/exit area remain clear.

A stabilized entrance should be removed only when there is no longer the potential for vehicle tracking to occur. This is typically after the site has been stabilized.

When wheel wash equipment is used, be sure that the wash water is discharged to a sediment trap prior to discharge. Also inspect channels conveying the water from the wash area to the sediment trap and stabilize areas that may be eroding.

When a construction entrance/exit is removed, excess sediment from the aggregate should be removed and disposed of appropriately. The entrance should be promptly stabilized with a permanent surface following removal, typically by paving.



**Photograph VTC-2.** A vehicle tracking control pad with wheel wash facility. Photo courtesy of Tom Gore.

**APPENDIX C**

# **SPILL PREVENTION, CONTROL, AND COUNTERMEASURE PLAN (SPCC)**

## **PREVENTION MEASURES**

The contractor will ensure that all practicable measures are taken to minimize the potential for and consequences of a spill during construction of a project. The contractor is responsible for complying with applicable environmental and safety laws and regulations to provide training to construction to personnel and equipment designed to prevent pollution.

The proper use of materials and equipment greatly reduces the potential of contamination. The following is a list of general preventative practices to be used during construction of the project:

- The contractor must supply each construction crew with spill kits containing a sufficient quantity of absorbent and barrier materials to adequately contain and recover potential spills of fuels or lubricating oils.
- The contractor will train all personnel who handle fuels and other regulated substances to follow spill prevention procedures and to quickly and effectively contain and cleanup spills.
- Fuels and lubricating oils for vehicles or heavy equipment will not be stored in wetlands or near water bodies and refueling of construction equipment will be limited to upland areas.
- Authorized personnel shall only dispense fuels during daylight hours. Fuels dispensing operations may not be left unattended.
- On-site vehicles will be monitored for leaks and receive regular maintenance to reduce the chance of leaks. Vehicle maintenance wastes, including used oils and other fluids, will be handled and managed by personnel trained in the procedures outlined in this plan.
- Storage Containers will display labels that identify the contents of the container and whether the contents are hazardous. The contractor shall maintain and provide, on demand, copies of all Material Safety Data Sheets (MSDS).
- In the event a spill does occur the contractor will meet with personnel who handle fuels and other regulated substances to discuss the procedures that were or were not followed and how to prevent such spills in the future.

## **SPILL RESPONSE – Cleanup and Removal Procedures**

**NOTE: IN CASE OF FIRE, EVACUATE ALL PERSONNEL FROM THE IMMEDIATE AREA, RENDER FIRST AID TO ANYONE WHO IS INJURED, AND DIAL 911 IMMEDIATELY. TAKE APPROPRIATE STEPS TO PROTECT HUMAN LIFE AND TO CONTROL FIRES FIRST. SPILL CONTROL IS SECONDARY.**

- Upon detection of any spill, the first action to be taken is to ensure personal safety. All possible ignition sources, including running engines, electrical equipment (including cellular telephones, etc.), or other hazards will be immediately turned off or removed from the area. The extent of the spill and the nature of the spilled material will be evaluated to determine if remedial actions could result in any health hazards, escalation of the spill, or further damage that would intensify the problem. If such conditions exist, a designated employee will oversee the area of the spill and the construction SWMP Administrator will be notified immediately.
- The source of the spill will be identified and if possible the flow of pollutants stopped if it can be done safely. However, no one should attend to the source or begin cleanup of the spill until ALL emergency priorities (fire, injuries, etc.) have been addressed.

### **Small Spills**

Small spills (usually <5 gallons) consist of minor quantities of gasoline, oil, anti-freeze, or other materials that can be cleaned up by a single employee using readily available materials.

The following procedures should be used for clean-up of small spills:

- a. Ensure personal safety, evaluate the spill, and if possible, stop the flow of pollutants.
- b. Contain the spread of the spill using absorbents, portable berms, sandbags, or other available measures.
- c. Spread absorbent materials on the area to soak up as much of the liquid as possible and to prevent infiltration into the soil.
- d. Once the liquids have been absorbed, remove all absorbents from the spill and place the materials in a suitable storage container. On paved areas, wipe any remaining liquids from the surface and place the materials in a storage container. Do not spray or wash down the area using water. For open soil areas, excavate any contaminated soil as soon as possible and place the soil in a suitable storage container. All materials will then be transported off-site for disposal.

- e. If immediate transfer and storage of the contaminated soil is not practical, excavate and place the contaminated soil on a double thickness sheet of 3-mil or higher polyethylene film. In addition, a small berm should be formed around the outer edges of the soil stockpile, underneath the polyethylene film, to ensure that contaminants are not washed from the site during precipitation events and that materials do not seep through the berm.
- f. Record all significant facts and information about the spill, including the following:
  - Type of pollutant
  - Location
  - Parent source
  - Estimated volume
  - Time of discovery
  - Actions taken to clean up spill
- g. Notify the SWMP Administrator of the spill and provide the information from Item f. The SWMP Administrator will then contact the City of Greeley.

### **Medium to Large Spills**

Medium to large spills consist of larger quantities of materials (usually >5 – 25 gallons) that are used on site that cannot be controlled by a single employee. Generally, a number of facility personnel will be needed to control the spill and a response may require the suspension of other facility activities.

The following procedure shall be used for the cleanup of medium to large spills:

- a. Ensure personal safety, evaluate the spill, and if possible, stop the flow of pollutants.
- b. Immediately dispatch a front-end loader or similar equipment to the spill and construct a berm or berms down gradient of the spill to minimize the spread of potential pollutants. On paved surfaces, portable berms, sandbags, booms, or other measures will be used to control the lateral spread of the pollutants.
- c. When the spread of the spill has been laterally contained, contact the SWMP Administrator or designated facility employee and provide them information on the location, type, and amount of spilled material, and a briefing on the extent of the spread and measures undertaken to contain the contaminants.
- d. Depending on the nature of the spill, mobilize additional resources as needed to contain the contaminants.

- e. Cleanup will commence when the lateral spread has been contained and the notification to the SWMP Administrator has been made.
- f. Freestanding liquid will be bailed or pumped into 55-gallon storage drums, steel tanks, or other suitable storage containers. When all the liquid has been removed from the pavement or soil layer, absorbents will be applied to the surface and transferred to the storage containers when they have soaked up as much of the spill as possible.
- g. On paved surfaces, the remaining contaminants will be removed to the extent possible, with rags, sweeping, or similar measures. The area of the spill will not be sprayed or washed down using water. Any contaminant soaked materials will be placed into the storage containers with the other absorbents.
- h. The remaining contaminated soils will be excavated and loaded into a dump truck(s) for disposal off-site at a designated facility. If transport off-site is not immediately available, the remaining soils will be stockpiled on a double thickness sheet of 3-mil or higher polyethylene film. In addition, a small berm will be formed around the outer edges of the soil stockpile, underneath the polyethylene film, to ensure that contaminants are not washed from the site during precipitation and do not seep through the berm.
- i. Record all significant facts and information about the spill, including the following:
  - Type of pollutant
  - Location
  - Apparent source
  - Estimated volume
  - Time of discovery
  - Actions taken to clean up spill
- j. Provide the SWMP Administrator (or designated employee) with the information from Item i. The SWMP Administrator will then contact the City of Greeley.

## NOTIFICATION

Notification to the Colorado Department of Public Health & Environment (CDPHE) and the City of Greeley is required if there is any release or suspected release of any substance, including oil or other substances that spill into or threaten State waters. Unless otherwise noted, notifications are to be made by the SWMP Administrator and only after emergency responses related to the release have been implemented. This will prevent misinformation and assures that notifications are properly conducted.

The notification requirements are as follows:

1. **Spills into/or Threatens State Waters:** Immediate notification is required for releases that occur beneath the surface of the land or impact or threaten waters of the State (which include surface water, ground water, dry gullies and storm sewers leading to surface water) or threaten the public health and welfare. Notifications that will be made are:
  - a. For any substance, regardless of quantity, contact CDPHE at 1-877-518-5608. State as follows:
    - a) Give your name and the name and contact information of the SWMP Administrator.
    - b) Give location of spill (name of city) and it's source (e.g., manhole, tanker truck)
    - c) Describe the nature of the spill, type of products, estimate size of spill, whether the spill is ongoing and, if it is, the rate of flow and an estimate of the time that the spill will be fully controlled.
    - d) Describe type of action taken thus far, type of assistance or equipment needed.
  - b. For any quantity of oil or other fluids, call the National Response Center at 1-800-424-8802. State as follows:
    - a) Give your name.
    - b) Give location of spill (name of city and state).
    - c) Describe the nature of the spill, type of product, and estimate size of spill.
    - d) Describe type of action taken thus far, type of assistance or equipment needed.



2. **Reportable Quantity Spill on Land Surface:** Immediate notification is required of a release upon the land surface of an oil in quantity that exceeds 25 gallons, or of a hazardous substance that equals or exceeds 10 pounds or its reportable quantity under Section 101(14) of the Comprehensive Environmental Response, Compensation Liability Act (CERCLA) of 1980 as amended (40 CFR Part 302) and Section 329 (3) of the Emergency Planning and Community Right to Know Act of 1986 (40 CFR Part 355) whichever is less. This requirement does apply at a minimum to the substances listed in Table A below.

**TABLE A**

Substances Requiring Notification

SUBSTANCE	REPORTABLE QUANTITY
Motor Oil	25 Gallons
Hydraulic Oil	25 Gallons
Gasoline/Diesel Fuel	25 Gallons

The notification procedures to be followed are:

- a) Give your name.
  - b) Give location of spill (name of city and state).
  - c) Describe nature of the spill, type of product, and estimate size of spill.
  - d) Describe type of action taken thus far, type of assistance or equipment needed.
3. Notification is not required for release of oil upon the land surface of 25 gallons or less that will not constitute a threat to public health and welfare, the environmental or a threat of entering the waters of the State.
  4. Notification, as required in paragraphs 1 and 2 above, will be made to the CDPHE using the 24-hour telephone number to report environmental spills. All information known about the release at the time of discovery is to be included, such as the time of occurrence, quantity and type of material, location and any corrective or clean-up actions presently being taken. Table B lists these phone numbers.

## SPILL RESPONSE CONTACTS

TABLE B

Emergency Notification Contacts

Name/Agency	Number
Fire Department	911
Police Department	911
Ambulance	911
Hospital	911
National Response Center	1-800-424-8802
CDPHE – Report Environmental Spills (24 hrs/day)	1-877-518-5608
City of Greeley	970-350-9792
Colorado Emergency Planning Committee	303-273-1622
Also contact SWMP Administrator and Owner	See Narrative Report Information Worksheet

It is the responsibility of the SWMP Administrator to contact the City of Greeley, CDPHE, and/or the National Response Center.

- The National Response Center is to be contacted when a release containing a hazardous substance or oil in an amount equal to or in excess of a reportable quantity established under either 40 CFR 110, 4- DFR 117, or 40 CFR 302 occurs during a 24-hour period.
- Notification to the CDPHE and City of Greeley is required if there is any release or suspected release of any material, including oil or hazardous substances that spill into or threaten state waters.

## **REPORTS**

The CDPHE and CITY OF GREELEY require written notification of a spill or discharge of oil or other substance that may cause pollution of the waters of the State of Colorado. A written report must be submitted to the CDPHE Water Quality Control Division (WQCD) and the City of Greeley Erosion Control Staff within five days after becoming aware of the spill or discharge.

The CDPHE and CITY OF GREELEY require a written final report within 15 days for all releases of an oil or hazardous substance that require implementation of a contingency plan. The CDPHE and CITY OF GREELEY may also require additional reports on the status of the clean up until any required remedial action has been complete.

Written notification of reports must contain at a minimum:

1. Date, time, and duration of the release.
2. Location of the release.
3. Person or persons causing and responsible for the release.
4. Type and amount of oil or substance released.
5. Cause of the release.
6. Environmental damage caused by the release.
7. Actions taken to respond, contain, and clean up the release.
8. Location and method of ultimate disposal of the oil or other fluids.
9. Actions taken to prevent a reoccurrence of the release.
10. Any known or anticipated acute or chronic health risks associated with the release.
11. When appropriate advice regarding medical attention necessary for exposed individuals.

**APPENDIX D**

**COLORADO DEPARTMENT OF TRANSPORTATION  
STORMWATER MANAGEMENT PLAN  
FIELD INSPECTION REPORT**

(5) Project Name	
(6) Project Number	(7) Region
(8) Project Code (SA #)	
(1) Date of Inspection	(9) Reason for Inspection :  <input type="checkbox"/> Required Maximum 14 Calendar Day Inspection <input type="checkbox"/> Required 30 Calendar Day Inspection for Completed Projects <input type="checkbox"/> Required Storm Event Inspection <input type="checkbox"/> Complaint: _____ <input type="checkbox"/> Other: _____
(2) Contractor Name	
(3) Contractor's Inspector Name (print)	
(4) CDOT's Inspector Name (print)	

**(10) CONSTRUCTION SITE ASSESSMENT**

<input type="checkbox"/> Construction site perimeter contained. Offsite tracking minimized.	<input type="checkbox"/> Estimate disturbed area at the time of the inspection. _____ Acres
<input type="checkbox"/> Disturbed areas contained.	<input type="checkbox"/> Areas used for material and waste storage and fueling contained.

**(11) SWMP MANAGEMENT**

<input type="checkbox"/> Changes made to the SWMP during construction? Yes / No	<input type="checkbox"/> Changes approved and noted on the plans? Yes / No
---	--

**BEST MANAGEMENT PRACTICES (BMPs)**

(12) BMP Type	(13) Practice Req/Used	(14) Reason	(15) Maintenance/ Sediment Removal Required Y/N	(16) Course of Action	(17) Date for Action to be Completed
<b>EROSION CONTROL</b>					
Seeding					
Mulching					
Blankets					
Check Dams					
Earth Berms					
Diversion					
Embankment Protector					
Outlet Protection					
Other:					
Other:					
<b>SEDIMENT CONTROL</b>					
Inlet Protection					
Erosion Bales					
Silt Fence					
Sediment Trap/Basin					

# Stormwater Management Plan Field Inspection Report Instructions

1. Project Name: Indicate the name of the project for which the report is being completed.
2. Project Number: Indicate the project number of the project for which the report is being completed.
3. Region: Indicate the CDOT region in which the project is located.
4. Project Code: Indicate the CDOT project code number for which the report is being completed.
5. Date of Inspection: Indicate the date of the inspection.
6. Contractor Name: Indicate the name of the contractor performing the work being inspected.
7. Contractor's Inspector Name: Indicate the name of the Erosion Control Supervisor designated by the contractor.
8. CDOT's Inspector Name: Indicate the name of the CDOT representative performing the inspection with the contractor. This person should be the Project Engineer or an authorized representative.
9. Reason for Inspection: Indicate the purpose for the inspection. The types of inspections include the following:
  - "Required 14 Calendar Day Inspection". These inspections are required at least every 14 calendar days during the life of the construction project.
  - "Required 30 Day Inspection for Completed Projects". These inspections are required at least every 30 calendar days following the completion of the construction project where final stabilization has not been achieved.
  - "Required Storm Event Inspection". These inspections are required after a storm event that results in runoff.
  - Inspection as a response to a complaint.
  - Inspection for any other reason.

The first three types of inspections are required to comply with CDOT Standard Specifications and the Colorado Discharge Permit System General Permit for Stormwater Discharges Associated with Construction Activity (CDPS General Permit).
10. Construction Site Assessment: Inspect the noted areas of the construction site and indicate with a "✓" the items which apply.
  - "Construction site perimeter contained". Are the appropriate BMPs in place and offsite sediment tracking minimized? Is there any evidence of pollutants entering a storm drainage system?
  - "Disturbed areas contained". Are the appropriate BMPs implemented to minimize erosion or sediment tracking from the disturbed areas? Is there any evidence of pollutants entering a storm drainage system? Provide an estimate of the disturbed area at the time of the inspection.
  - "Areas used for material and waste storage and fueling contained". Are the appropriate BMPs implemented to prevent and contain spills? Are wastes removed from the site and disposed of properly? Are the storage areas located at least 50 feet from a watercourse? Is there any evidence of pollutants entering a storm drainage system?
11. SWMP Management: Indicate whether changes have been made to the SWMP during construction and whether the changes have been approved and documented.
12. BMP: The BMPs shown may not be a complete list of what is required by the SWMP. Cross out the BMPs not required by the SWMP and add the BMPs that are required. Additional sheets can be inserted to show all the BMPs required by the SWMP.
13. Practice Req/Used: This column can be used as follows:
  - If the BMP is required by the SWMP and implemented, indicate by placing a "✓" in both the "Req" and "Used" columns.
  - If the BMP is required by the SWMP, but not implemented, indicate by placing a "✓" in the "Req" column. Indicate the reason for the change in column (14), "Reason".
  - If the BMP has been added to the SWMP, indicate with a "✓" in the "Used" column. Indicate the reason for the change in column (14), "Reason".
14. Reason: Indicate the reason(s) for the deletion, addition, and modification of BMP(s) to the SWMP.
15. Maintenance/Sediment Removal Required: Indicate whether maintenance and sediment removal are required with a Yes or No. If maintenance and sediment removal are required, indicate what the action plan is in column (16), "Course of Action".
16. Course of Action: If maintenance and/or sediment removal is required, describe the action plan.
17. Date for Action to be Completed: Indicate the date for which the course of action will be completed. The course of action must be completed in a timely manner, but in no case more than 7 days after the inspection.

(12) BMP Type	(13) Practice Req/Used		(14) Reason	(15) Maintenance/ Sediment Removal Required Y/N	(16) Course of Action	(17) Date for Action to be Completed
Stabilized Construction Entrance						
Dewatering Structure						
Other:						
<b>MATERIALS HANDLING AND SPILL PREVENTION, WASTE MANAGEMENT AND GENERAL POLLUTION PREVENTION</b>						
Stockpile Management						
Materials Delivery and Storage						
Spill Prevention and Control						
Concrete Washout						
Concrete Saw Water Containment						
Solid Waste						
Sanitary Waste						
Maintenance and Fueling						
Street Sweeping Vacuuming						
Other:						
Other:						

Comments:

---

(18) INSPECTIONS AND MAINTENANCE PROGRAM	
<input type="checkbox"/> Inspection occurring at least every 14 calendar days.	Course of Action:
<input type="checkbox"/> Inspections occurring after storm events that result in runoff.	Course of Action:
<input type="checkbox"/> Inspections occurring at least every 30 calendar days since project completion.	Course of Action:
<input type="checkbox"/> Inspection reports retained at the construction project site.	Course of Action:
<input type="checkbox"/> Corrective measures completed within 7 calendar days of inspection.	Course of Action:
<b>CERTIFICATION</b>	
I certify this Stormwater Management Plan Field Inspection Report is complete and accurate.	
Contractor's Inspector Name	Date
CDOT's Inspector Name	Date

## Stormwater Management Plan Field Inspection Report Instructions

12. BMP: The BMPs shown may not be a complete list of what is required by the SWMP. Cross out the BMPs not required by the SWMP and add the BMPs that are required. Additional sheets can be inserted to show all the BMPs required by the SWMP.
13. Practice Req/Used: This column can be used as follows:
  - If the BMP is required by the SWMP and implemented, indicate by placing a "✓" in both the "Req" and "Used" columns.
  - If the BMP is required by the SWMP, but not implemented, indicate by placing a "✓" in the "Req" column. Indicate the reason for the change in column (14), "Reason".
  - If the BMP has been added to the SWMP, indicate with a "✓" in the "Used" column. Indicate the reason for the change in column (14), "Reason".
14. Reason: Indicate the reason(s) for the deletion, addition, and modification of BMP(s) to the SWMP.
15. Maintenance/Sediment Removal Required: Indicate whether maintenance and sediment removal are required with a Yes or No. If maintenance and sediment removal are required, indicate what the action plan is in column (16), "Course of Action".
16. Course of Action: If maintenance and/or sediment removal is required, describe the action plan.
17. Date for Action to be Completed: Indicate the date for which the course of action will be completed. The course of action must be completed in a timely manner, but in no case more than 7 days after the inspection.
18. Inspections and Maintenance: Evaluate the inspection and maintenance aspect of the construction project and check all that applies with an "✓". To comply with CDOT Standard Specification and the CDPS General Permit, all of the items identified must be adhered to.



**APPENDIX E**

# CENTERPLACE TURN LANE IMPROVEMENTS

A PORTION OF CENTERPLACE DRIVE WITH 46TH AND 44TH AVENUE, LOCATED IN  
SW1/4 OF SECTION 14, TOWNSHIP 5 NORTH, RANGE 66 WEST  
OF THE 6TH P.M., CITY OF GREELEY, COUNTY OF WELD, STATE OF COLORADO

## CONSTRUCTION PLANS

### KEY CONTACTS

#### GOVERNING AUTHORITIES:

**OWNER**  
CITY OF GREELEY - PUBLIC WORKS  
1001 9TH AVENUE  
GREELEY, CO 80631  
ATTN: BRIAN WARD 970-350-9357

**CIVIL ENGINEER**  
JR ENGINEERING  
7200 SOUTH ALTON WAY, SUITE C400  
CENTENNIAL, CO 80112  
ATTN: DAREN STERLING 303-267-6193

**GEOTECHNICAL ENGINEER**  
TERRACON CONSULTANTS, INC.  
1289 1ST AVENUE  
GREELEY, CO 80631  
ATTN: ERIC D. BERNHARDT 970-351-0460

#### UTILITIES

**ATMOS ENERGY**  
ATTN: JERRY ADAMS 970-304-2075

**CENTURY LINK**  
ATTN: CARSON ORTEGA 970-392-4837

**COMCAST**  
ATTN: KEVIN YOUNG 720-281-8666

**XCEL ENERGY**  
ATTN: TOM MALONE 970-395-1207

### BMP MAINTENANCE NOTE:

ALL EROSION AND SEDIMENT CONTROL PRACTICES AND OTHER MEASURES IDENTIFIED IN THE SWMP MUST BE MAINTAINED IN EFFECTIVE OPERATING CONDITION. PROPER SELECTION AND INSTALLATION OF BMPs AND IMPLEMENTATION OF COMPREHENSIVE INSPECTION AND MAINTENANCE PROCEDURES, IN ACCORDANCE WITH THE SWMP, SHOULD BE ADEQUATE TO MEET THIS CONDITION. BMPs THAT ARE NOT ADEQUATELY MAINTAINED IN ACCORDANCE WITH GOOD ENGINEERING, HYDROLOGIC AND POLLUTION CONTROL PRACTICES, INCLUDING REMOVAL OF COLLECTED SEDIMENT OUTSIDE THE ACCEPTABLE TOLERANCES OF THE BMPs, ARE CONSIDERED TO BE NO LONGER OPERATING EFFECTIVELY AND MUST BE ADDRESSED.

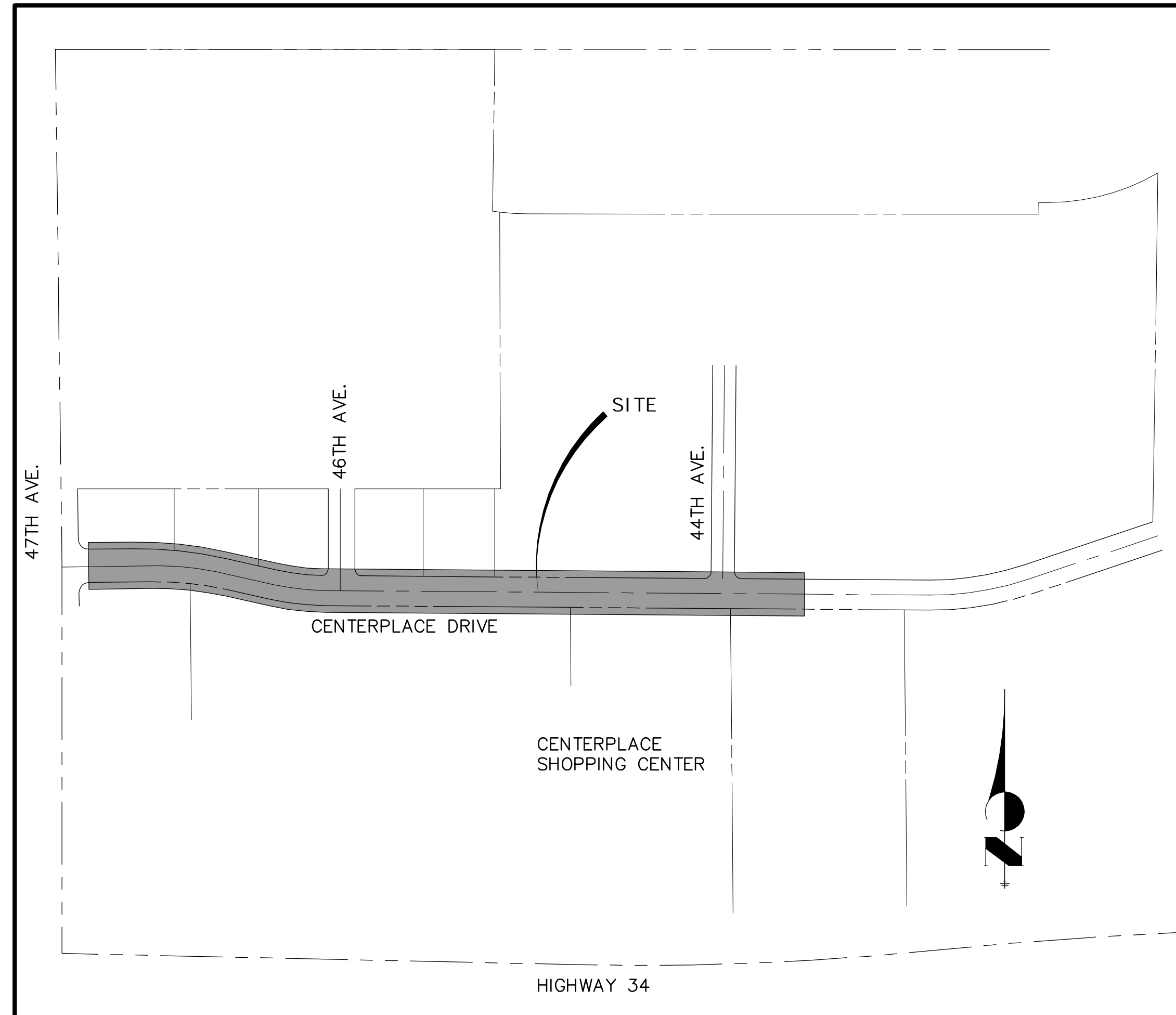

VICINITY MAP

SCALE: 1"=300'

### PROJECT NUMBERS

ENGINEERING PROJECT NO. 39722.02

### SHEET INDEX

1	COVER SHEET
2	LEGEND
3-5	INITIAL SWMP
6-8	INTERIM SWMP
9-11	FINAL SWMP
12-14	DETAIL SHEETS
TOTAL - 14	

### ABBREVIATIONS

AC	ACRE	CMP	CORRUGATED METAL PIPE	EX	EXISTING	IRR	IRRIGATION	PI	POINT OF INTERSECTION	TOB	TOP OF BOX
AD	ALGEBRAIC DIFFERENCE	CO	CLEAN OUT	FDP	FINAL DEVELOPMENT PLAN	KB	KICK (THRUST) BLOCK	PKWY	PARKWAY	TOC	TOP OF CURB OR CONCRETE
AH	AHEAD	COCs	CITY OF COLORADO SPRINGS	FDR	FINAL DRAINAGE REPORT	LB	POUND	PL	PROPERTY LINE	TOF	TOP OF FOUNDATION
ARCH	ARCHITECT	CONC	CONCRETE	FES	FLARED END SECTION	LE	LANDSCAPE EASEMENT	PR	PROPOSED	TOP	TOP OF PIPE
ASCE	AMERICAN SOCIETY OF CIVIL ENGINEERS	CR	CIRCLE	FF	FINISHED FLOOR ELEVATION	LF	LINEAR FOOT	PRC	POINT OF REVERSE CURVATURE	TW	TOP OF WALL
ASSY	ASSEMBLY	CSP	CORRUGATED STEEL PIPE	FG	FINISHED GRADE	LN	LANE	PT	POINT OF TANGENCY	TYP	TYPICAL
AVE	AVENUE	CSU	COLORADO SPRINGS UTILITIES	FIH	FIRE HYDRANT	LOMR	LETTER OF MAP REVISION	PV	PLUG VALVE	UDFCD	URBAN DRAINAGE AND FLOOD CONTROL DISTRICT
BB	BOX BASE	CT	COURT	FL	FLOWLINE	LP	LOW POINT	PVC	POLYVINYL CHLORIDE	UE	UTILITY EASEMENT
BK	BACK	CTRB	CONCRETE THRUST REDUCER	FIL	FILING	LS	LUMP SUM	R	RADIUS	U&DE	UTILITY & DRAINAGE EASEMENT
BNDY	BOUNDARY	FO	FIBER OPTIC CABLE	LT	LEFT	MAX	MAXIMUM	RCBC	REINFORCED CONCRETE BOX CULVERT	UGE	UNDERGROUND ELECTRIC
BOP	BOTTOM OF PIPE	CY	CUBIC YARD	GB	GRADE BREAK	M/D	MASTERY DENSITY	RCP	REINFORCED CONCRETE PIPE	VCP	VITRIFIED CLAY PIPE
BOV	BLOW OFF VALVE	DBPS	DRAINAGE BASIN PLANNING STUDY	GE	GAS EASEMENT	MDDP	MASTER DEVELOPMENT DRAINAGE PLAN	RD	ROAD	VPC	VERTICAL POINT OF CURVATURE
BFV	BUTTERFLY VALVE	DE	DRAINAGE EASEMENT	GL	GAS LINE	MH	MANHOLE	ROW	RIGHT OF WAY	VPI	VERTICAL POINT OF INTERSECTION
BLVD	BOULEVARD	DIA	DIAMETER	GPS	GLOBAL POSITIONING SYSTEM	MIN	MINIMUM	RT	RIGHT	VPT	VERTICAL POINT OF TANGENCY
BW	BOTTOM OF WALL	DIP	DUCTILE IRON PIPE	GVS	GATE VALVE	MS	MOUNTABLE SIDEWALK	S	SOUTH	VTC	VEHICLE TRACKING CONTROL
C&G	CURB & GUTTER	DR	DRIVE	HBP	HOT BITUMINOUS PAVEMENT	N	NORTH	SAN	SANITARY SEWER	W	WEST
CATV	CABLE TELEVISION	DRC	DESIGN REVIEW COMMITTEE	HC	HANDICAP	NRCP	NON-REINFORCED CONCRETE PIPE	SF	SQUARE FOOT	WL	WATER LINE
CB	CATCH BASIN	DU	DWELLING UNITS	HDC	HIGH DEFLECTION COUPLING	ODP	OFFICIAL DEVELOPMENT PLAN	ST	STREET	WM	WATER MAIN
CBG	CONCRETE BOX CULVERT	DAY	DAY	HDPE	HIGH DENSITY POLYETHYLENE	OHE	OVERHEAD ELECTRIC	STM	STATION	WRD	WATER RESOURCES DEPARTMENT
CDOT	COLORADO DEPARTMENT OF TRANSPORTATION	E	EAST	HGL	HYDRAULIC GRADE LINE	OBU	OVERHEAD UTILITY	SY	SQUARE YARD	WS	WATER SURFACE
CDS	CUL-DE-SAC	EGL	ENERGY GRADE LINE	HMA	HOT MIX ASPHALT	PC	POINT OF CURVATURE	SY-IN	SQUARE YARD INCH	WSE	WATER SURFACE ELEVATION
CF	CUBIC FOOT	EL	ELEVATION	HOA	HOME OWNERS ASSOCIATION	PCC	POINT OF COMPOUND	TB	THRUST BLOCK	WTR	WATER
CFS	CUBIC FEET PER SECOND	ELEC	ELECTRIC	HP	HIGH POINT	PCR	CURVATURE	TBC	TOP BACK OF CURB	YR	YEAR
CIP	COMPLETE IN PLACE	EDA	EDGE OF ASPHALT	HR	HOUR	PDP	PRELIMINARY DEVELOPMENT PLAN	TBW	TOP BACK OF WALK		
CL	CENTER LINE	EPC	EL PASO COUNTY	I	IRRIGATION	TEL	TELEPHONE	TEL	TELEPHONE		
CLOMR	CONDITIONAL LETTER OF MAP REVISION	ERCP	ELLIPTICAL RCP	IE	IRRIGATION EASEMENT	TN	TON	TOA	TOP OF ASPHALT		
CLR	CLEAR	ESMT	EASEMENT	INT	INTERSECTION						
		EST	ESTIMATE	INV	INVERT						

COVER SHEET  
CENTERPLACE TURN LANE IMPROVEMENTS  
JOB NO. 39722.02  
12/20/19  
SHEET 1 OF 14



Know what's below.  
Call before you dig.

### ENGINEER'S STATEMENT

PREPARED UNDER MY SUPERVISION

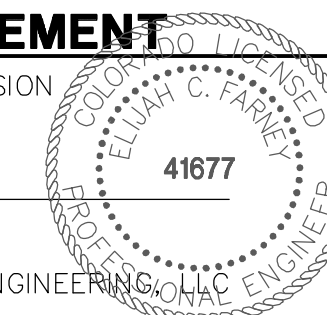

ELIJAH C. FARNEY, P.E.  
COLORADO P.E. 41677  
FOR AND ON BEHALF OF JR ENGINEERING



Centennial 303-740-9393 • Colorado Springs 719-593-2593  
Fort Collins 970-491-9888 • www.jrengineering.com

### LAYER LINETYPE LEGEND

	EXISTING	PROPOSED
PHASE LINE	---	---
MATCH LINE	---	---
SECTION LINE	---	---
BOUNDARY LINE	---	---
PROPERTY LINE	---	---
EASEMENT LINE	---	---
RIGHT OF WAY	---	---
R.O.W. A LINE	A ---	A ---
CENTERLINE	---	---
CITY LIMITS	---	---
WIRE FENCE	x --- x	x --- x
CHAIN LINK FENCE	o --- o	o --- o
WOOD FENCE	o --- o	o --- o
MASONRY FENCE	o --- o	o --- o
GUARDRAIL	o --- o	o --- o
CONC. BARRIER	o --- o	o --- o
CABLE TV	TV --- TV	TV --- TV
ELECTRIC	E --- E	E --- E
FIBER OPTIC	FO --- FO	FO --- FO
GAS MAIN	G --- G	G --- G
IRRIGATION MAIN	IRR --- IRR	IRR --- IRR
OIL/PETRO. MAIN	O --- O	O --- O
OVERHEAD UTILITY	OHU --- OHU	OHU --- OHU
SANITARY SEWER	S --- S	S --- S
STORM DRAIN	---	---
TELEPHONE	T --- T	T --- T
WATER MAIN	W --- W	W --- W
RAW WATER LINE	---	RWL --- RWL
SWALE/WATERWAY FLOWLINE	---	---
DIVERSION DITCH	---	---
DIVERSION CHANNEL	---	---
MAJOR DRAINAGE BASIN	---	---
MINOR DRAINAGE BASIN	---	---
TOP OF SLOPE	---	---
TOE OF SLOPE	---	---
EDGE OF WATER	---	---
INDEX CONTOUR	6100 ---	6100 ---
INTERMEDIATE CONTOUR	---	---
DEPRESSION CONT. (INDEX)	6100 ---	6100 ---
DEPRESSION CONT. (INTER)	---	---
TOP OF CUTS	---	---
TOE OF FILLS	---	---
CUT AND FILL LINE	SF --- SF	SF --- SF
SILT FENCE	---	---
100 YEAR FLOODPLAIN	100YR ---	100YR ---
500 YEAR FLOODPLAIN	500YR ---	500YR ---
FLOODWAY	FLDWY ---	FLDWY ---
BASE FLOOD ELEVATION	---	---
EDGE OF WETLANDS	---	---
STONE WALL	---	---

### UTILITIES LEGEND

	EXISTING	PROPOSED
<b>STORM SEWER</b>		
MANHOLE	⊙	●
STORM INLET	■	■
AREA INLET - SQUARE	□	■
AREA INLET - ROUND	○	■
FLARED END SECTION	▷	▷
RIPRAP	▨	▨
<b>SANITARY SEWER</b>		
LINE MARKER	⊙ <sub>Mr San</sub>	●
SERVICE MARKER	△	●
CLEAN-OUT	○	●
MANHOLE W/ DIRECTIONAL FLOW ARROW	⊙ <sub>4</sub>	●
<b>WATER LINE</b>		
LINE MARKER	⊙ <sub>Mr W</sub>	●
SERVICE MARKER	△	●
FIRE HYDRANT	⊙	●
FIRE CONNECTION	⊙	●
MANHOLE	⊙	●
BEND	⊙	●
BLOW-OFF VALVE	⊙	●
WELL	⊙ <sub>WELL</sub>	●
METER	⊙	●
VALVE	⊙	●
REDUCER	⊙	●
THRUST BLOCK	⊙	●
CROSS	⊙	●
PLUG W/ THRUST BLOCK	⊙	●
TEE	⊙	●
REVERSE ANCHOR ANODE	⊙	●
AIR & VACUUM VALVE ASSEMBLY	⊙	●
TRANSMISSION BLOW-OFF ASSEMBLY	⊙	●
<b>GAS LINE</b>		
MARKER	⊙ <sub>Mr G</sub>	●
SERVICE MARKER	△	●
METER	⊙	●
VALVE	⊙	●
PLUG	⊙	●
TEE	⊙	●
<b>DRY UTILITIES</b>		
CABLE TV MARKER	⊙ <sub>Mr TV</sub>	●
CABLE TELEVISION PEDESTAL	□	●
ELECTRIC MARKER	⊙ <sub>Mr E</sub>	●
ELECTRIC SERVICE MARKER	△	●
ELECTRICAL PEDESTAL	□	●
ELECTRICAL METER	⊙	●
ELECTRICAL MANHOLE	⊙	●
FIBER-OPTIC MARKER	⊙ <sub>Mr FO</sub>	●
IRRIGATION PEDESTAL	□	●
TELEPHONE MARKER	⊙ <sub>Mr T</sub>	●
TELEPHONE PEDESTAL	□	●
TELEPHONE MANHOLE	⊙	●
UTILITY POLE	○	●
GUY ANCHOR	○	●
GUY POLE	○	●
<b>MISC. UTILITIES</b>		
VENT PIPE	⊙ <sub>VP</sub>	●
TEST HOLE DESIGNATOR	⊙ <sub>TH#</sub>	●
FIRM/AGENCY		

### MONUMENTATION LEGEND

ALUMINUM CAP - FOUND	● <sub>AC</sub>
BRASS CAP - FOUND	● <sub>BC</sub>
BENCHMARK - FOUND	+
CROSS - FOUND	+
MONUMENT - SET	○
MONUMENT - FOUND (DEFAULT)	●
MONUMENT - FOUND (ALTERNATE 1)	■
MONUMENT - FOUND (ALTERNATE 2)	■
MONUMENT - FOUND (ALTERNATE 3)	▲
MONUMENT - FOUND (ALTERNATE 4)	▲
MONUMENT - FOUND (ALTERNATE 5)	▲
MONUMENT - FOUND (ALTERNATE 6)	▲
MONUMENT - FOUND (ALTERNATE 7)	▲
NAIL & WASHER - FOUND	● <sub>NAIL &amp; WASHER</sub>
PANEL - FOUND	■
PK NAIL - FOUND	● <sub>PK NAIL</sub>
ROW MONUMENT - FOUND	■
ROW MARKER - FOUND	■
SECTION CORNER - FOUND	+
SECTION CORNER - SET	+
QUARTER-SECTION CORNER - FOUND	+
QUARTER-SECTION CORNER - SET	+
SECTION CENTER - FOUND	○
SECTION CENTER - FOUND	○
CONTROL/TRaverse POINT - SET	△

### TRAFFIC LEGEND

	EXISTING	PROPOSED
PARKING METER	⊙	⊙
TRAFFIC SIGNAL BOX	□	□
TRAFFIC SIGNAL POLE	□	□
TRAFFIC SIGNAL BARRICADE	---	---
GUARD RAIL POST	---	---
IMPACT ATTENUATOR	---	---
BRIDGE STYLE HIGHWAY SIGN POST	---	---
CANTILEVER STYLE HIGHWAY SIGN POST	---	---
RAILROAD MARKER/SIGN	⊙	⊙
STREET LIGHT	⊙	⊙
STREET LIGHT - SINGLE	⊙	⊙
STREET LIGHT - DOUBLE	⊙	⊙
LUMINAIRE	⊙	⊙
ALTERNATE LUMINAIRE	⊙	⊙
SIGNAL MAST ARM W/ LUMINAIRE	⊙	⊙
PEDESTAL POLE FOUNDATION	⊙	⊙
TRAFFIC SIGNAL POLE	⊙	⊙
ROUND PULL BOX	⊙	⊙
MEDIUM PULL BOX	⊙	⊙
LARGE PULL BOX (20X33X15)	⊙	⊙
SIGNAL HEAD WITHOUT BACK PLATE	⊙	⊙
SIGNAL HEAD WITH BACK PLATE	⊙	⊙
PEDESTRIAN SIGNAL HEAD	⊙	⊙
VIDEO IMAGE DETECTOR	⊙	⊙
OPTICOM DETECTOR	⊙	⊙
VEHICLE DETECTION ZONE	⊙	⊙

### STORM WATER MANAGEMENT

KEY	SYMBOL
CHECK DAM	⊙
CONSTRUCTION ROAD STABILIZATION	⊙
CURB SOCK INLET PROTECTION	⊙
CONCRETE WASHOUT AREA	⊙
DIVERSION DITCH AND DIKE, TEMPORARY	⊙
DIVERSION CHANNEL, TEMPORARY	⊙
DEWATERING	⊙
EROSION CONTROL BLANKET	⊙
INLET FILTER	⊙
INLET PROTECTION	⊙
MULCHING	⊙
OUTLET PROTECTION	⊙
PAVED FLUME	⊙
PERMANENT SEEDING	⊙
REINFORCED CONCRETE DAM	⊙
ROUGH CUT STREET CONTROL	⊙
SEDIMENT BASIN	⊙
SEDIMENT CONTROL LOG	⊙
SILT FENCE	⊙
SURFACE ROUGHENING	⊙
STABILIZED STAGING AREA	⊙
SEDIMENT TRAP	⊙
STRAW BALE BARRIER	⊙
TERRACING	⊙
TEMPORARY SEEDING	⊙
TEMPORARY STREAM CROSSING CULVERT/BRIDGE	⊙
TEMPORARY STREAM CROSSING FORD TYPE	⊙
TEMPORARY SLOPE DRAIN	⊙
VEHICLE TRACKING CONTROL	⊙
VEHICLE TRACKING CONTROL WITH WASH RACK	⊙

### DRAINAGE REPORT PLANS

KEY	SYMBOL
BASIN DESIGNATION (NO COEFFICIENT)	⊙
BASIN DESIGNATION (1 COEFFICIENT)	⊙
BASIN DESIGNATION (2 COEFFICIENTS)	⊙
ANALYSIS POINT IDENTIFIER	⊙
BASIN DESIGNATION (HISTORIC)	⊙
BASIN DESIGNATION (DEVELOPED)	⊙
SUB-BASIN DESIGNATION (DEVELOPED)	⊙
DRAINAGE PIPE IDENTIFIER	⊙
DRAINAGE POINT IDENTIFIER (HEXAGONAL)	⊙
DRAINAGE POINT IDENTIFIER (TRIANGULAR)	⊙
SWM DESIGNATION 1	⊙
SWM DESIGNATION 2	⊙
SWM DESIGNATION 3	⊙
SWM DESIGNATION 4	⊙

### LANDSCAPE LEGEND

	EXISTING	PROPOSED
TREE - CONIFEROUS	⊙	⊙
TREE - DECIDUOUS	⊙	⊙
SHRUB/BUSH	⊙	⊙
SHRUBS AND BUSHES	⊙	⊙
IRRIGATION BOX	⊙	⊙
IRRIGATION SPRINKLER	⊙	⊙
IRRIGATION VALVE	⊙	⊙
BOLLARD	⊙	⊙
FLAGPOLE	⊙	⊙



Know what's below.  
Call before you dig.

### ENGINEER'S STATEMENT

PREPARED UNDER MY SUPERVISION

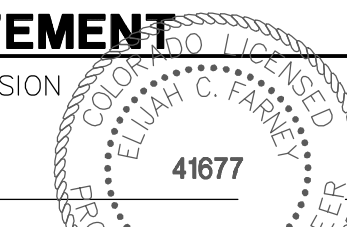

ELJAH C. FARNEY, P.E.  
COLORADO P.E. 41677  
FOR AND ON BEHALF OF JR ENGINEERING, LLC ENGINEER DATE

UNTIL SUCH TIME AS THESE DRAWINGS ARE APPROVED BY THE AGENCIES, OR ENGINEERING APPROVES THEIR USES DESIGNATED BY WRITTEN AUTHORIZATION.  
 PREPARED FOR: **BRIAN WARD**  
 CITY OF GREELEY-PUBLIC WORKS  
 1001 9TH AVENUE  
 GREELEY, CO 80631  
 (970) 350-9792  
**J.R. ENGINEERING**  
 A Westman Company  
 Central 303-740-0883 • Colorado Springs 719-588-2583  
 Fort Collins 970-491-9888 • www.jrengineering.com  
 BY: \_\_\_\_\_ DATE: \_\_\_\_\_  
 No. REVISION: \_\_\_\_\_  
 H-SCALE: N/A V-SCALE: N/A DATE: 12/20/19 DESIGNED BY: N/A DRAWN BY: N/A CHECKED BY: \_\_\_\_\_  
**CENTERPLACE TURN LANE IMPROVEMENTS**  
**LEGEND**  
 SHEET 2 OF 14  
 JOB NO. 39722.02

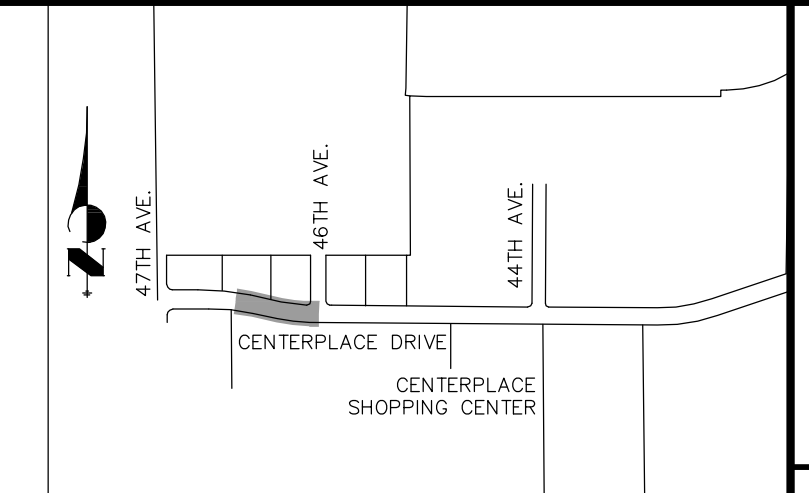

KEY MAP  
SCALE: 1"=1000'

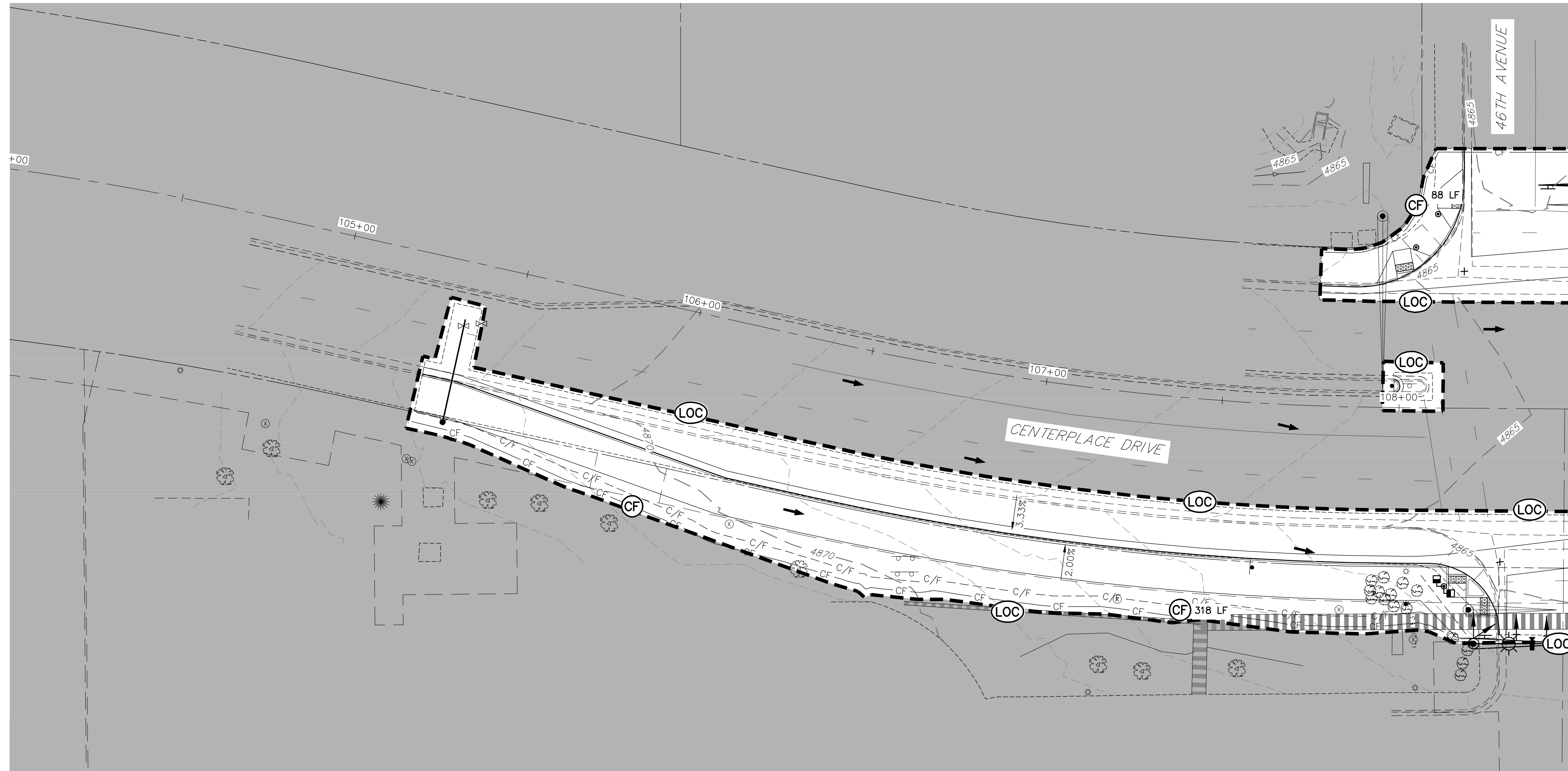

CENTERPLACE DRIVE  
STA: 104+00 TO 108+50

MATCH STA. 108+50  
SEE SHEET 13

**LEGEND**

SF	SILT FENCE	C/F	PROPOSED CUT & FILL LINE
CF	CONSTRUCTION FENCE	5080	EXISTING INDEX CONTOUR
IP	STORM DRAIN INLET PROTECTION		EXISTING CONTOUR
OP	STORM DRAIN OUTLET PROTECTION	5080	PROPOSED INDEX CONTOUR
LS	LANDSCAPE RESTORATION		PROPOSED CONTOUR
CWA	CONCRETE WASHOUT AREA	SB	SEDIMENT BASIN
SCL	SEDIMENT CONTROL LOG	ECB	EROSION CONTROL BLANKET
	DRAINAGE DIRECTION	VTC	VEHICLE TRACKING CONTROL
	PROPOSED ROW	SSA	STABILIZED STAGING AREA
	PROPOSED EASEMENT	DD	DIVERSION DITCH
LOC	LIMITS OF CONSTRUCTION	RS	ROCK SOCK

**NOTES**

- INSTALL EROSION/SEDIMENT CONTROL ONLY DURING APPROPRIATE PHASING, AND AS APPROVED BY THE ENGINEER. HOWEVER, INLET PROTECTION SHALL BE INSTALLED IMMEDIATELY AFTER CONSTRUCTION OF NEW INLETS.
- SECTION 13 OF THE CITY OF GREELEY DESIGN STANDARDS AND CONSTRUCTION SPECIFICATIONS SHALL APPLY FOR ALL EXCAVATION AND EMBANKMENT AREAS. THE ROADWAY SUBGRADE MATERIALS SHALL BE FREE OF ORGANIC MATERIALS AND OTHER DELETERIOUS MATERIALS AND SHALL BE THOROUGHLY SCARIFIED, AND WELL MIXED.
- CONTRACTOR MAY INSTALL SILT FENCE TO RIGHT-OF-WAY OR TEMPORARY CONSTRUCTION EASEMENT.
- THE CONTRACTOR SHALL FIND AN APPROPRIATE LOCATION TO SET UP CONCRETE WASHOUT AREA, VEHICLE TRACKING CONTROL, AND STABILIZED STAGING AREA AND SUBMIT TO THE CITY FOR APPROVAL.
- THE TOTAL DISTURBANCE AREA IS 0.76AC. NO STATE PERMIT OR STORM WATER MANAGEMENT PLAN ARE REQUIRED.

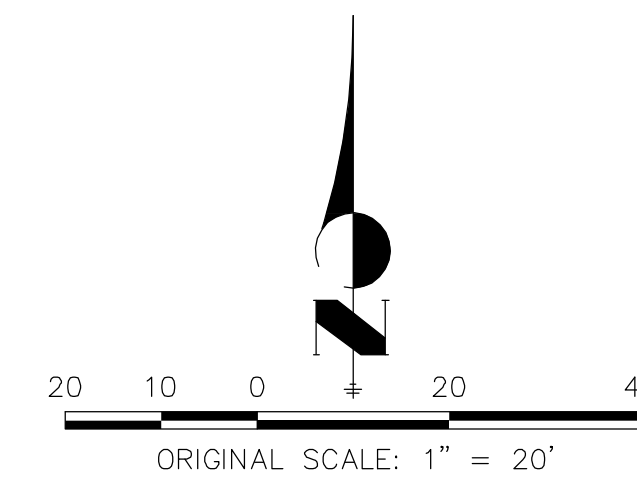

**ENGINEER'S STATEMENT**

PREPARED UNDER MY SUPERVISION

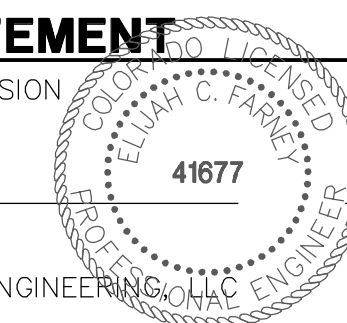

ELJUAH C. FARNEY, P.E.  
COLORADO P.E. 41677  
FOR AND ON BEHALF OF JR ENGINEERING, LLC

CENTERPLACE TURN LANE  
IMPROVEMENTS  
GRADING & EROSION  
CONTROL PLAN  
INITIAL STAGE

SHEET 3 OF 14

JOB NO. 39722.02

No. REVISION BY DATE

H-SCALE	V-SCALE	DATE	DESIGNED BY	DRAWN BY	CHECKED BY
1"=20'	N/A	12/20/19	SRM	SRM	

PREPARED FOR  
**BRIAN WARD**  
CITY OF GREELEY—PUBLIC WORKS  
1001 9TH AVENUE  
GREELEY, CO 80631  
(970) 350-9792

**J.R. ENGINEERING**  
A Westman Company  
Central 303-740-9888 • Colorado Springs 719-588-2583  
Fort Collins 970-491-9888 • www.jrengineering.com

UNTIL SUCH TIME AS THESE DRAWINGS ARE APPROVED BY THE APPROPRIATE REVIEWING AGENCIES, JR ENGINEERING APPROVES THEIR USE ONLY AS DESIGNATED BY WRITTEN AUTHORIZATION.

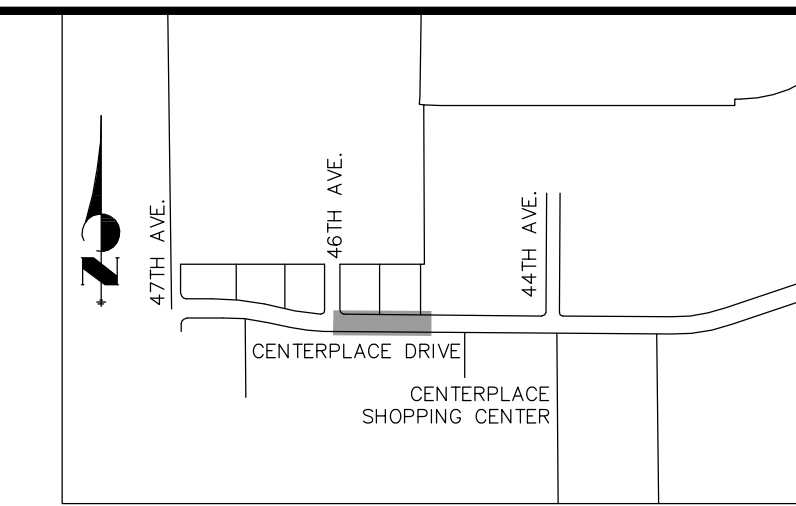

**KEY MAP**  
SCALE: 1"=1000'

UNTIL SUCH TIME AS THESE DRAWINGS ARE APPROVED BY THE APPROPRIATE REVIEWING AGENCIES, JR ENGINEERING APPROVES THEIR USE FOR PURPOSES DESIGNATED BY WRITTEN AUTHORIZATION.

PREPARED FOR  
**BRIAN WARD**  
CITY OF GREELEY—PUBLIC WORKS  
1001 9TH AVENUE  
GREELEY, CO 80631  
(970) 350-9792

**J.R. ENGINEERING**  
A Westman Company  
Central 303-740-9888 • Colorado Springs 719-588-2583  
Fort Collins 970-491-9888 • www.jrengineering.com

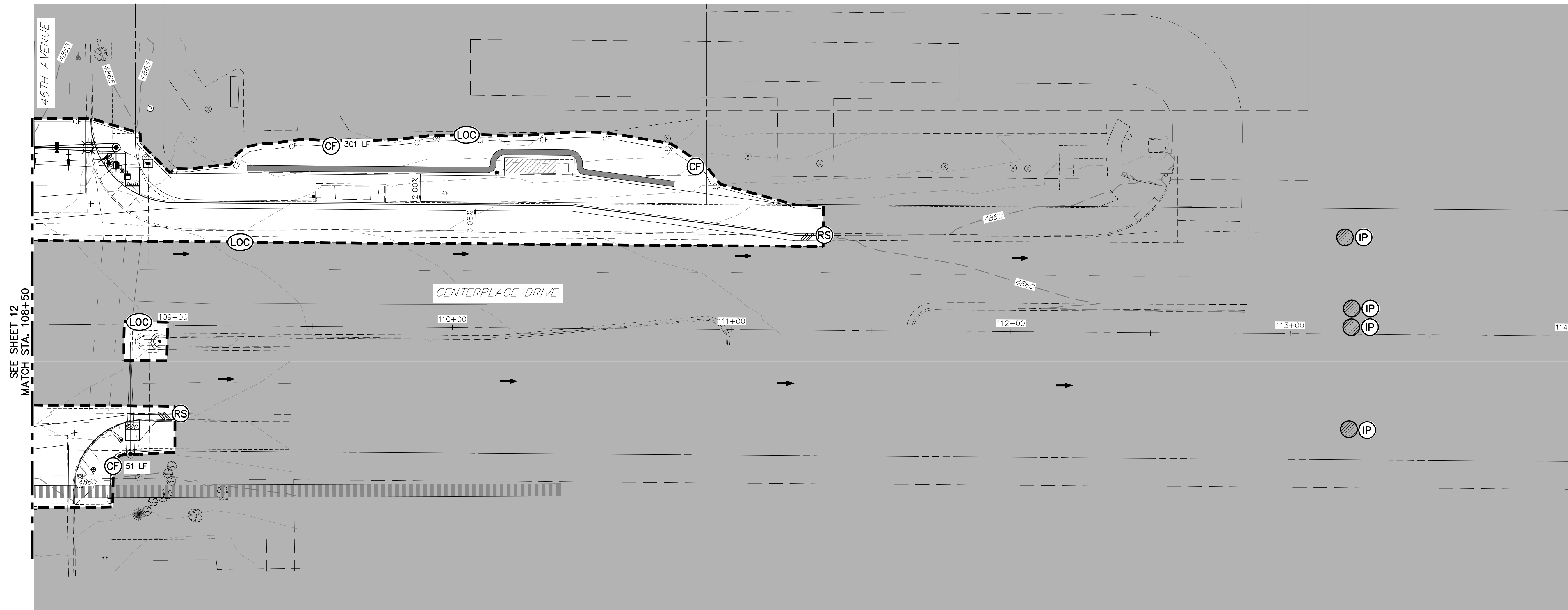

**CENTERPLACE DRIVE**  
STA: 108+50 TO 114+00

LEGEND	
(SF)	SILT FENCE
(CF)	CONSTRUCTION FENCE
(IP)	STORM DRAIN INLET PROTECTION
(OP)	STORM DRAIN OUTLET PROTECTION
(LS)	LANDSCAPE RESTORATION
(CWA)	CONCRETE WASHOUT AREA
(SCL)	SEDIMENT CONTROL LOG
(←)	DRAINAGE DIRECTION
(---)	PROPOSED ROW
(- - -)	PROPOSED EASEMENT
(--- LOC ---)	LIMITS OF CONSTRUCTION
(--- C/F ---)	PROPOSED CUT & FILL LINE
(-5080-)	EXISTING INDEX CONTOUR
(- - -)	EXISTING CONTOUR
(5080)	PROPOSED INDEX CONTOUR
(---)	PROPOSED CONTOUR
(SB)	SEDIMENT BASIN
(ECB)	EROSION CONTROL BLANKET
(VTC)	VEHICLE TRACKING CONTROL
(SSA)	STABILIZED STAGING AREA
(DD)	DIVERSION DITCH
(RS)	ROCK SOCK

- NOTES**
1. INSTALL EROSION/SEDIMENT CONTROL ONLY DURING APPROPRIATE PHASING, AND AS APPROVED BY THE ENGINEER. HOWEVER, INLET PROTECTION SHALL BE INSTALLED IMMEDIATELY AFTER CONSTRUCTION OF NEW INLETS.
  2. SECTION 13 OF THE CITY OF GREELEY DESIGN STANDARDS AND CONSTRUCTION SPECIFICATIONS SHALL APPLY FOR ALL EXCAVATION AND EMBANKMENT AREAS. THE ROADWAY SUBGRADE MATERIALS SHALL BE FREE OF ORGANIC MATERIALS AND OTHER DELETERIOUS MATERIALS AND SHALL BE THOROUGHLY SCARIFIED, AND WELL MIXED.
  3. CONTRACTOR MAY INSTALL SILT FENCE TO RIGHT-OF-WAY OR TEMPORARY CONSTRUCTION EASEMENT.
  4. THE CONTRACTOR SHALL FIND AN APPROPRIATE LOCATION TO SET UP CONCRETE WASHOUT AREA, VEHICLE TRACKING CONTROL, AND STABILIZED STAGING AREA AND SUBMIT TO THE CITY FOR APPROVAL.
  5. THE TOTAL DISTURBANCE AREA IS 0.76AC. NO STATE PERMIT OR STORM WATER MANAGEMENT PLAN ARE REQUIRED.

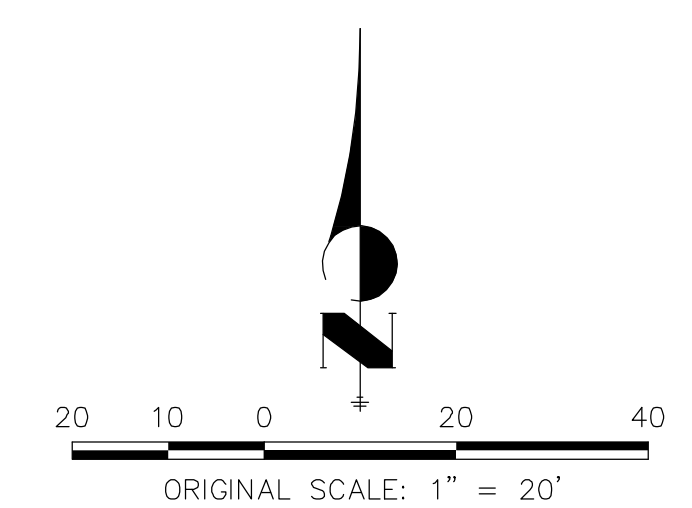

**ENGINEER'S STATEMENT**

PREPARED UNDER MY SUPERVISION

ELIJAH C. FARNEY, P.E.  
COLORADO P.E. 41677  
FOR AND ON BEHALF OF JR ENGINEERING, LLC

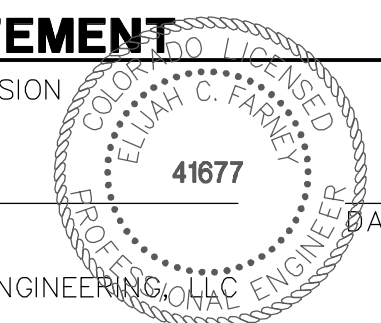

H-SCALE	V-SCALE	DATE	DESIGNED BY	DRAWN BY	CHECKED BY	No.	REVISION	BY	DATE
<b>CENTERPLACE TURN LANE IMPROVEMENTS</b> <b>GRADING &amp; EROSION CONTROL PLAN</b> <b>INITIAL STAGE</b>									
SHEET 4 OF 14									
JOB NO. 39722.02									



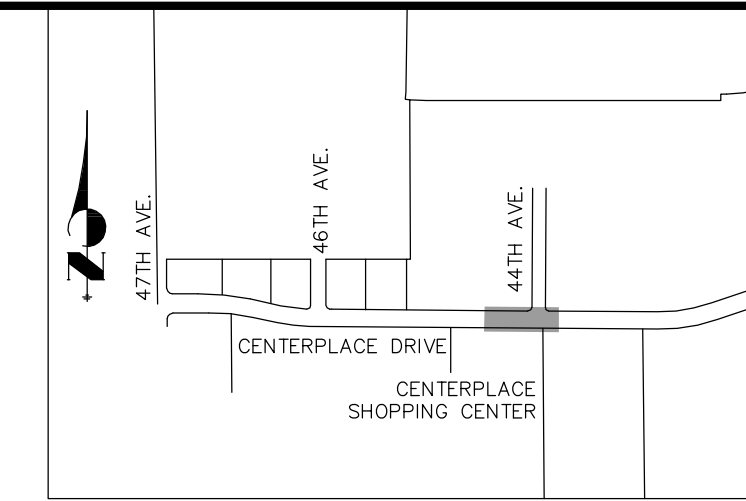

KEY MAP  
SCALE: 1"=1000'

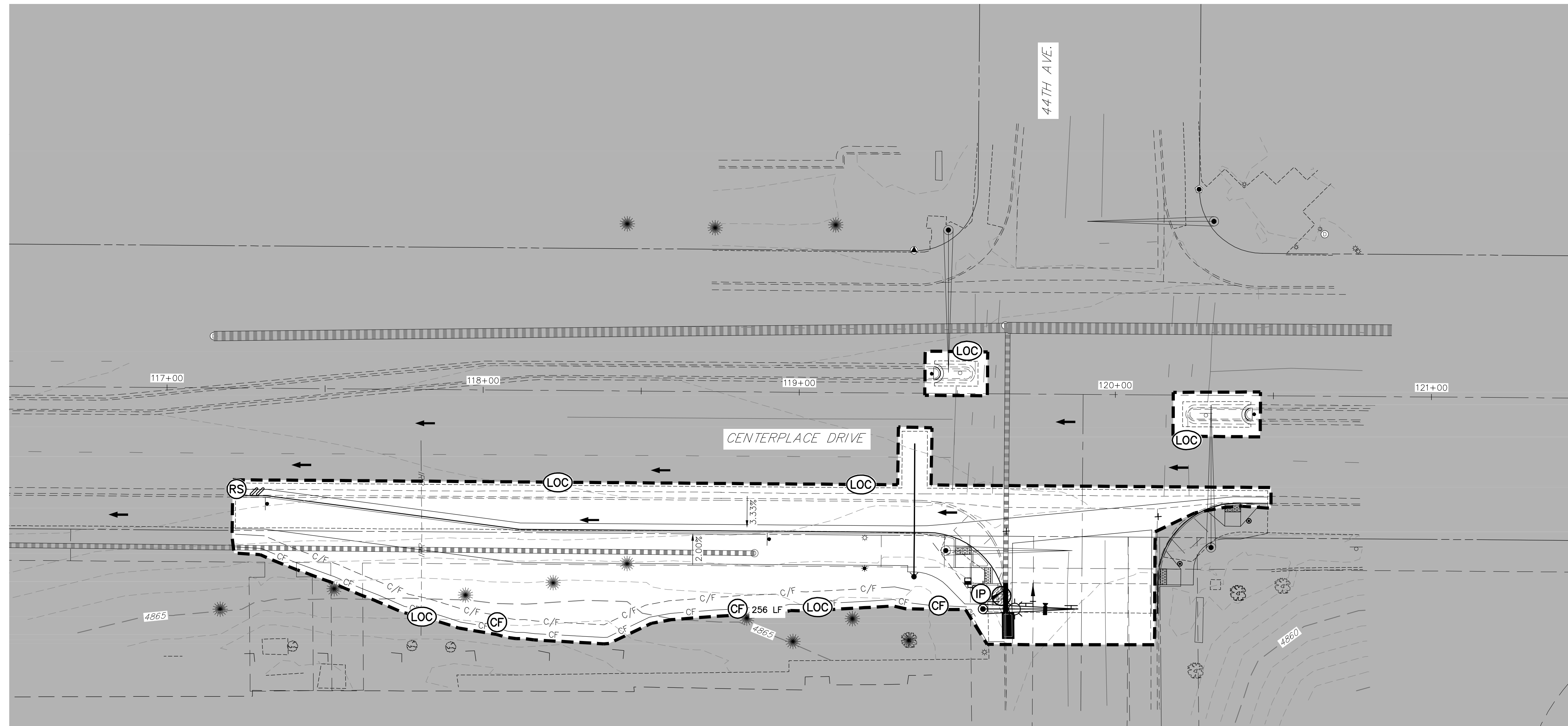

CENTERPLACE DRIVE  
STA: 116+50 TO 121+50

**LEGEND**

(SF)	SF	SILT FENCE	--- C/F ---	PROPOSED CUT & FILL LINE
(CF)	CF	CONSTRUCTION FENCE	- - - 5080 - - -	EXISTING INDEX CONTOUR
(IP)		STORM DRAIN INLET PROTECTION	---	EXISTING CONTOUR
(OP)		STORM DRAIN OUTLET PROTECTION	---	PROPOSED INDEX CONTOUR
(LS)		LANDSCAPE RESTORATION	---	PROPOSED CONTOUR
(CWA)		CONCRETE WASHOUT AREA	(SB)	SEDIMENT BASIN
(SCL)		SEDIMENT CONTROL LOG	(ECB)	EROSION CONTROL BLANKET
		DRAINAGE DIRECTION	(VTC)	VEHICLE TRACKING CONTROL
---		PROPOSED ROW	(SSA)	STABILIZED STAGING AREA
---		PROPOSED EASEMENT	(DD)	DIVERSION DITCH
--- LOC ---		LIMITS OF CONSTRUCTION	(RS)	ROCK SOCK

**NOTES**

1. INSTALL EROSION/SEDIMENT CONTROL ONLY DURING APPROPRIATE PHASING, AND AS APPROVED BY THE ENGINEER. HOWEVER, INLET PROTECTION SHALL BE INSTALLED IMMEDIATELY AFTER CONSTRUCTION OF NEW INLETS.
2. SECTION 13 OF THE CITY OF GREELEY DESIGN STANDARDS AND CONSTRUCTION SPECIFICATIONS SHALL APPLY FOR ALL EXCAVATION AND EMBANKMENT AREAS. THE ROADWAY SUBGRADE MATERIALS SHALL BE FREE OF ORGANIC MATERIALS AND OTHER DELETERIOUS MATERIALS AND SHALL BE THOROUGHLY SCARIFIED, AND WELL MIXED.
3. CONTRACTOR MAY INSTALL SILT FENCE TO RIGHT-OF-WAY OR TEMPORARY CONSTRUCTION EASEMENT.
4. THE CONTRACTOR SHALL FIND AN APPROPRIATE LOCATION TO SET UP CONCRETE WASHOUT AREA, VEHICLE TRACKING CONTROL, AND STABILIZED STAGING AREA AND SUBMIT TO THE CITY FOR APPROVAL.
5. THE TOTAL DISTURBANCE AREA IS 0.76AC. NO STATE PERMIT OR STORM WATER MANAGEMENT PLAN ARE REQUIRED.

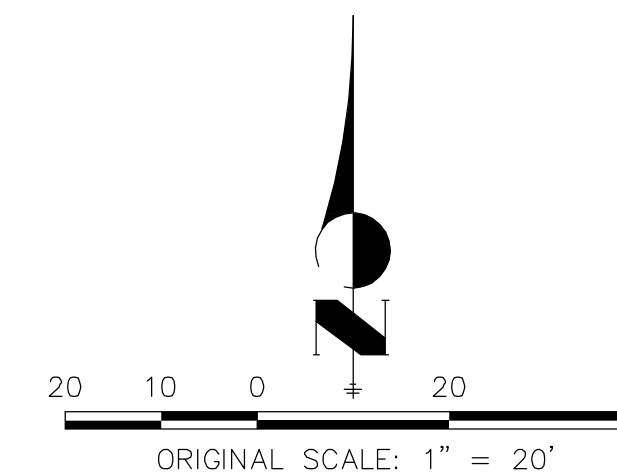

**ENGINEER'S STATEMENT**

PREPARED UNDER MY SUPERVISION

ELIJAH C. FARNEY, P.E.  
COLORADO P.E. 41677  
FOR AND ON BEHALF OF JR ENGINEERING, LLC

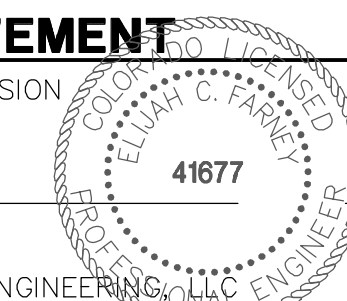

CENTERPLACE TURN LANE  
IMPROVEMENTS  
GRADING & EROSION  
CONTROL PLAN  
INITIAL STAGE

SHEET 5 OF 14

JOB NO. 39722.02

No.	REVISION	BY	DATE

UNTIL SUCH TIME AS THESE DRAWINGS ARE APPROVED BY THE APPROPRIATE REVIEWING AGENCIES, JR ENGINEERING APPROVES THEIR USE. USES DESIGNATED BY WRITTEN AUTHORIZATION.

PREPARED FOR  
**BRIAN WARD**  
CITY OF GREELEY—PUBLIC WORKS  
1001 9TH AVENUE  
GREELEY, CO 80631  
(970) 350-9792

**J.R. ENGINEERING**  
A Westrian Company  
Central 303-740-9888 • Colorado Springs 719-588-2583  
Fort Collins 970-491-9888 • www.jrengineering.com

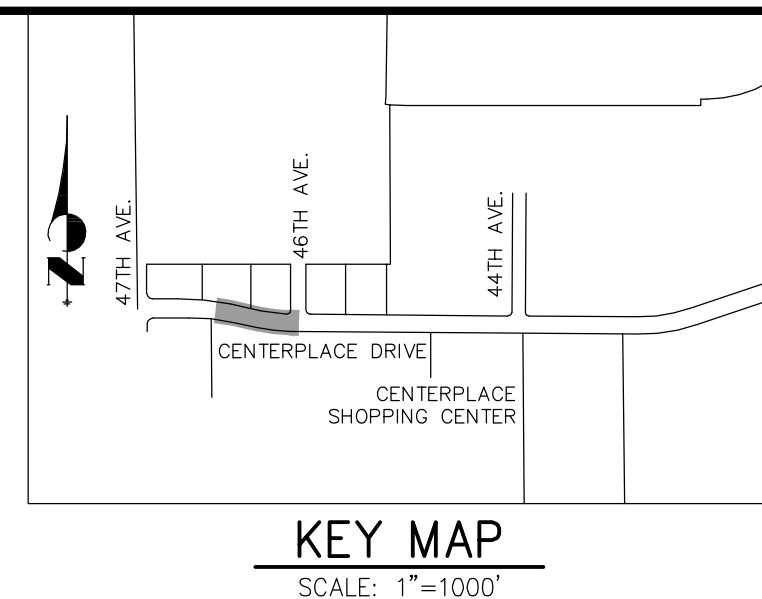
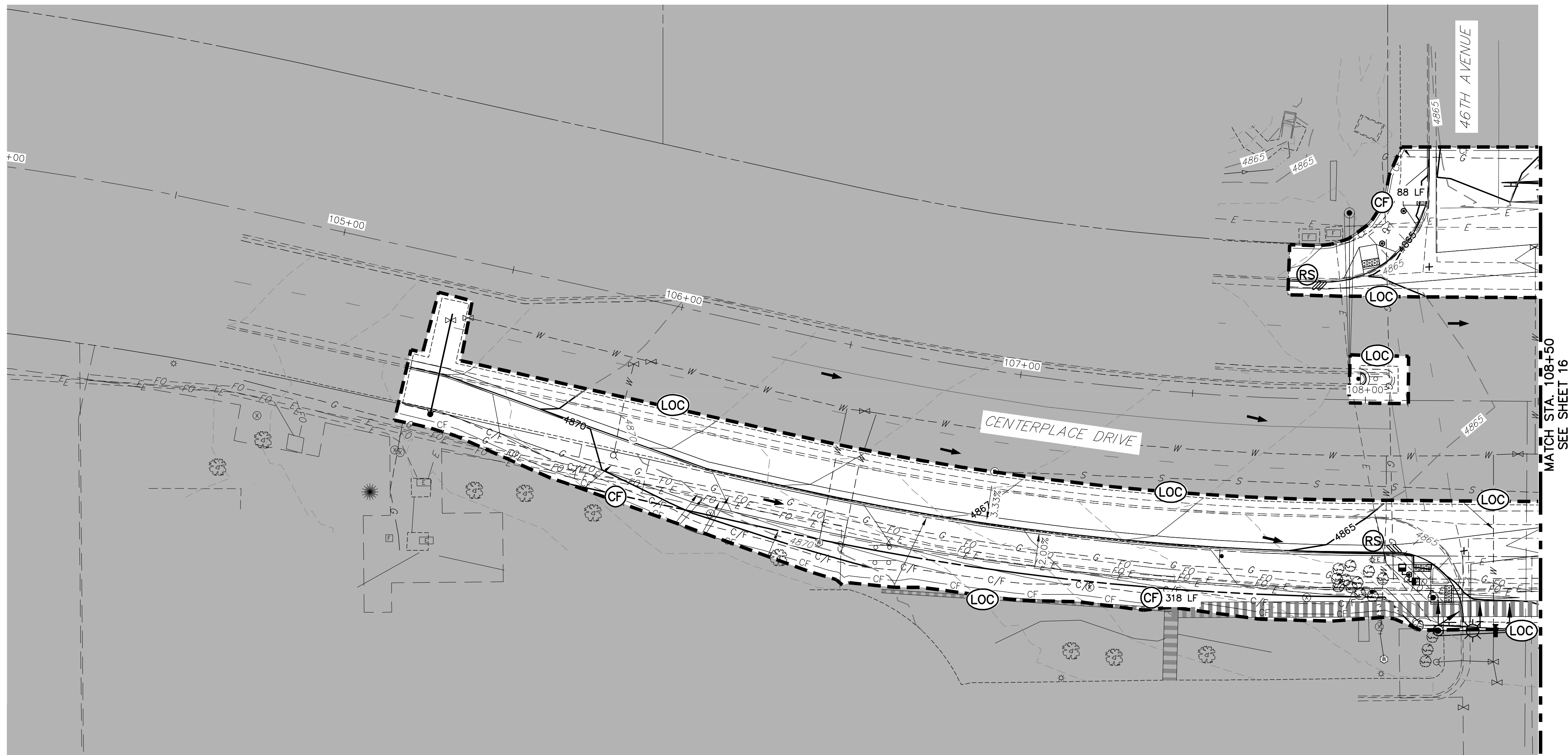

**CENTERPLACE DRIVE**  
STA: 104+00 TO 108+50

LEGEND				
(SF)	SF	SILT FENCE	- - - - C/F -	PROPOSED CUT & FILL LINE
(CF)	CF	CONSTRUCTION FENCE	- - - - 5080 - -	EXISTING INDEX CONTOUR
(IP)	(IP)	STORM DRAIN INLET PROTECTION	- - - -	EXISTING CONTOUR
(OP)	(OP)	STORM DRAIN OUTLET PROTECTION	- - - - 5080 - -	PROPOSED INDEX CONTOUR
(LS)	(LS)	LANDSCAPE RESTORATION	- - - -	PROPOSED CONTOUR
(CWA)	(CWA)	CONCRETE WASHOUT AREA	(SB)	SEDIMENT BASIN
(SCL)	(SCL)	SEDIMENT CONTROL LOG	(ECB)	EROSION CONTROL BLANKET
←	←	DRAINAGE DIRECTION	(VTC)	VEHICLE TRACKING CONTROL
- - - -	- - - -	PROPOSED ROW	(SSA)	STABILIZED STAGING AREA
- - - -	- - - -	PROPOSED EASEMENT	(DD)	DIVERSION DITCH
- - - - LOC - - - -	- - - - LOC - - - -	LIMITS OF CONSTRUCTION	(RS)	ROCK SOCK

- NOTES**
- INSTALL EROSION/SEDIMENT CONTROL ONLY DURING APPROPRIATE PHASING, AND AS APPROVED BY THE ENGINEER. HOWEVER, INLET PROTECTION SHALL BE INSTALLED IMMEDIATELY AFTER CONSTRUCTION OF NEW INLETS.
  - SECTION 13 OF THE CITY OF GREELEY DESIGN STANDARDS AND CONSTRUCTION SPECIFICATIONS SHALL APPLY FOR ALL EXCAVATION AND EMBANKMENT AREAS. THE ROADWAY SUBGRADE MATERIALS SHALL BE FREE OF ORGANIC MATERIALS AND OTHER DELETERIOUS MATERIALS AND SHALL BE THOROUGHLY SCARIFIED, AND WELL MIXED.
  - CONTRACTOR MAY INSTALL SILT FENCE TO RIGHT-OF-WAY OR TEMPORARY CONSTRUCTION EASEMENT.
  - THE CONTRACTOR SHALL FIND AN APPROPRIATE LOCATION TO SET UP CONCRETE WASHOUT AREA, VEHICLE TRACKING CONTROL, AND STABILIZED STAGING AREA AND SUBMIT TO THE CITY FOR APPROVAL.
  - THE TOTAL DISTURBANCE AREA IS 0.76AC. NO STATE PERMIT OR STORM WATER MANAGEMENT PLAN ARE REQUIRED.

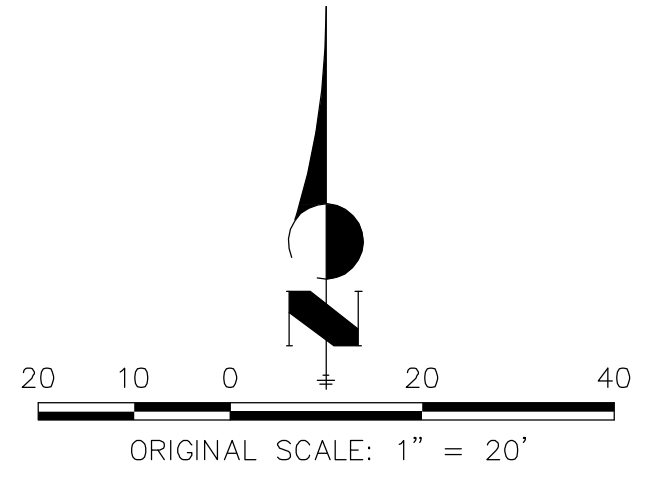

**ENGINEER'S STATEMENT**

PREPARED UNDER MY SUPERVISION  
 ELIJAH C. FARNEY, P.E.  
 COLORADO P.E. 41677  
 FOR AND ON BEHALF OF JR ENGINEERING, LLC ENGINEER DATE

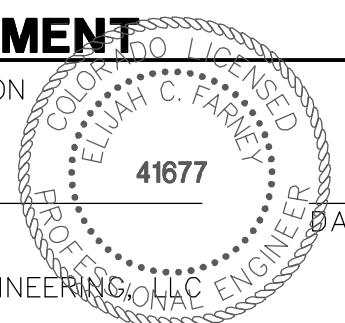

<b>CENTERPLACE TURN LANE IMPROVEMENTS</b>  <b>GRADING &amp; EROSION CONTROL PLAN</b>  <b>INTERIM STAGE</b>	H-SCALE	1"=20'
	V-SCALE	N/A
	DATE	12/20/19
	DESIGNED BY	SRM
	DRAWN BY	SRM
	CHECKED BY	
SHEET	6	OF 14
JOB NO.	39722.02	

No.	REVISION	BY	DATE

PREPARED FOR  
**BRIAN WARD**  
 CITY OF GREELEY—PUBLIC WORKS  
 1001 9TH AVENUE  
 GREELEY, CO 80631  
 (970) 350-9792

**J.R. ENGINEERING**  
 A Westman Company  
 Centennial 303-740-9888 • Colorado Springs 719-588-2583  
 Fort Collins 970-491-9888 • www.jrengineering.com

UNTIL SUCH TIME AS THESE DRAWINGS ARE APPROVED BY THE APPROPRIATE REVIEWING AGENCIES, OR ENGINEERING APPROVES THEIR USE, THESE DRAWINGS ARE DESIGNATED BY WRITTEN AUTHORIZATION.

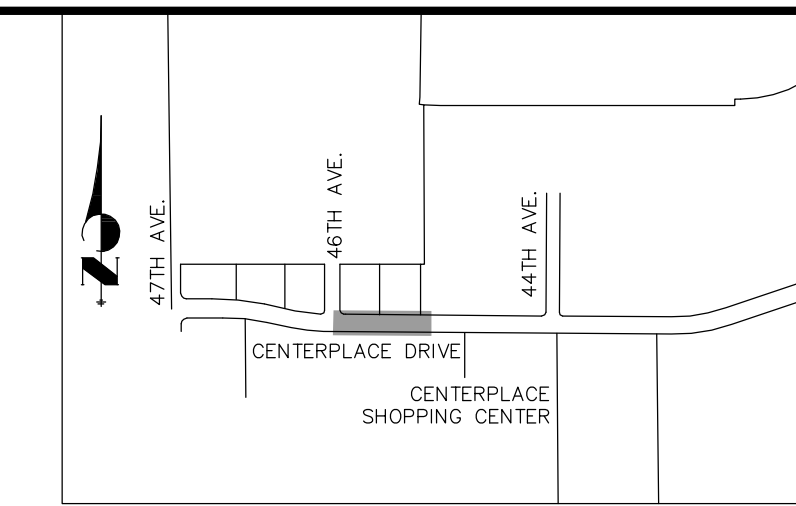

**KEY MAP**  
SCALE: 1"=1000'

UNTIL SUCH TIME AS THESE DRAWINGS ARE APPROVED BY THE APPROPRIATE REVIEWING AGENCIES, JR ENGINEERING APPROVES THEIR USE FOR PURPOSES DESIGNATED BY WRITTEN AUTHORIZATION.

PREPARED FOR  
**BRIAN WARD**  
CITY OF GREELEY—PUBLIC WORKS  
1001 9TH AVENUE  
GREELEY, CO 80631  
(970) 350-9792

**J.R. ENGINEERING**  
A Westman Company  
Central 303-740-9888 • Colorado Springs 719-588-2583  
Fort Collins 970-491-9888 • www.jrengineering.com

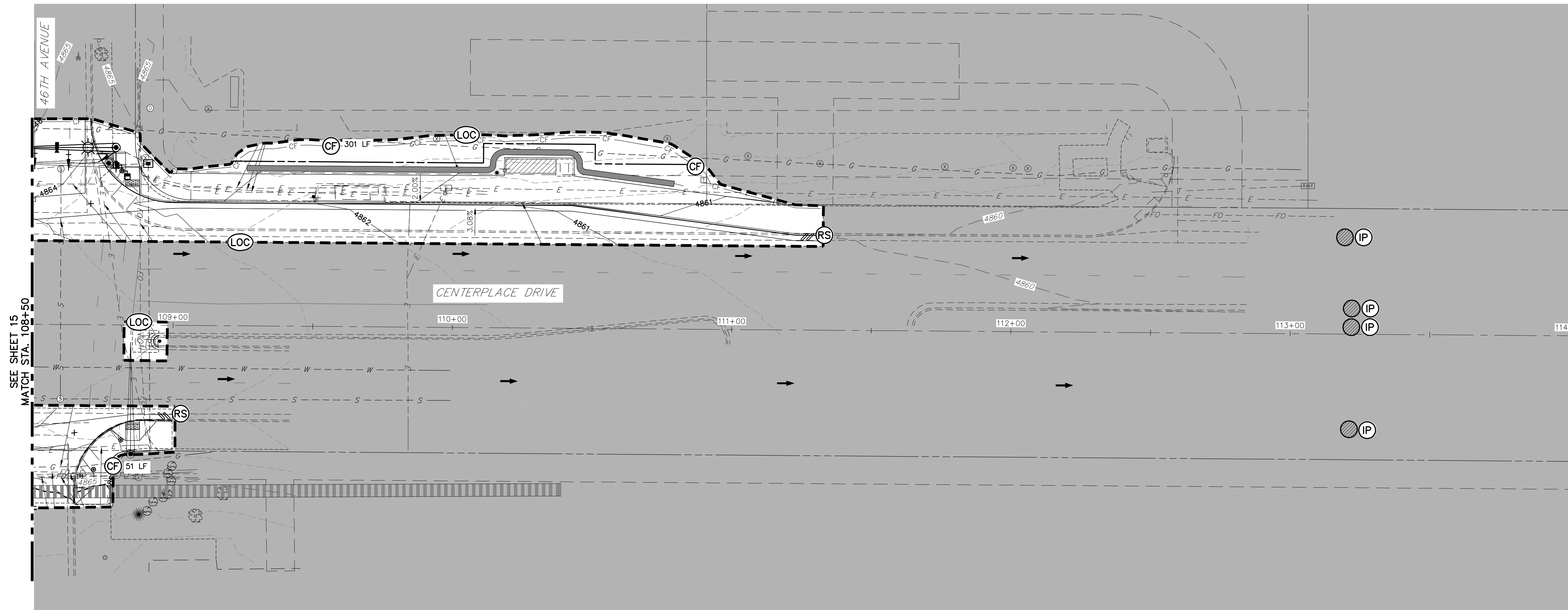

**CENTERPLACE DRIVE**  
STA: 108+50 TO 114+00

LEGEND	
(SF)	SILT FENCE
(CF)	CONSTRUCTION FENCE
(IP)	STORM DRAIN INLET PROTECTION
(OP)	STORM DRAIN OUTLET PROTECTION
(LS)	LANDSCAPE RESTORATION
(CWA)	CONCRETE WASHOUT AREA
(SCL)	SEDIMENT CONTROL LOG
(←)	DRAINAGE DIRECTION
(---)	PROPOSED ROW
(- - -)	PROPOSED EASEMENT
(--- LOC ---)	LIMITS OF CONSTRUCTION
(--- C/F ---)	PROPOSED CUT & FILL LINE
(-5080-)	EXISTING INDEX CONTOUR
(- - -)	EXISTING CONTOUR
(-5080-)	PROPOSED INDEX CONTOUR
(- - -)	PROPOSED CONTOUR
(SB)	SEDIMENT BASIN
(ECB)	EROSION CONTROL BLANKET
(VTC)	VEHICLE TRACKING CONTROL
(SSA)	STABILIZED STAGING AREA
(DD)	DIVERSION DITCH
(RS)	ROCK SOCK

- NOTES**
1. INSTALL EROSION/SEDIMENT CONTROL ONLY DURING APPROPRIATE PHASING, AND AS APPROVED BY THE ENGINEER. HOWEVER, INLET PROTECTION SHALL BE INSTALLED IMMEDIATELY AFTER CONSTRUCTION OF NEW INLETS.
  2. SECTION 13 OF THE CITY OF GREELEY DESIGN STANDARDS AND CONSTRUCTION SPECIFICATIONS SHALL APPLY FOR ALL EXCAVATION AND EMBANKMENT AREAS. THE ROADWAY SUBGRADE MATERIALS SHALL BE FREE OF ORGANIC MATERIALS AND OTHER DELETERIOUS MATERIALS AND SHALL BE THOROUGHLY SCARIFIED, AND WELL MIXED.
  3. CONTRACTOR MAY INSTALL SILT FENCE TO RIGHT-OF-WAY OR TEMPORARY CONSTRUCTION EASEMENT.
  4. THE CONTRACTOR SHALL FIND AN APPROPRIATE LOCATION TO SET UP CONCRETE WASHOUT AREA, VEHICLE TRACKING CONTROL, AND STABILIZED STAGING AREA AND SUBMIT TO THE CITY FOR APPROVAL.
  5. THE TOTAL DISTURBANCE AREA IS 0.76AC. NO STATE PERMIT OR STORM WATER MANAGEMENT PLAN ARE REQUIRED.

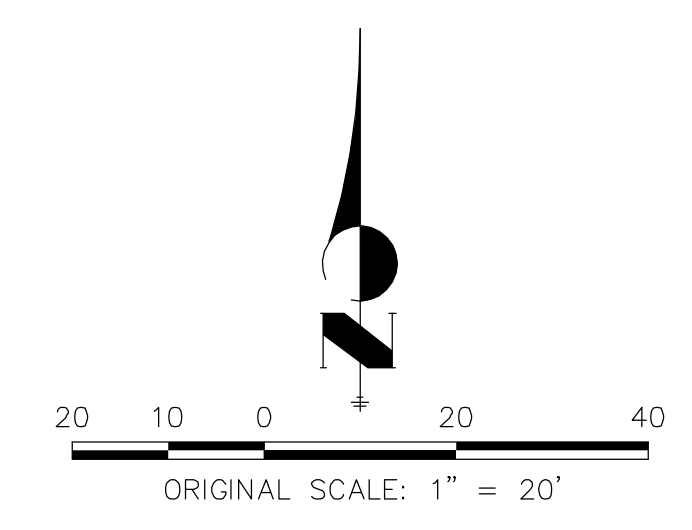

**ENGINEER'S STATEMENT**

PREPARED UNDER MY SUPERVISION

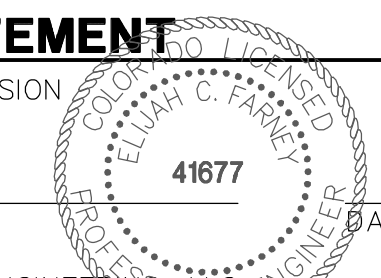

ELUAH C. FARNEY, P.E.  
COLORADO P.E. 41677  
FOR AND ON BEHALF OF JR ENGINEERING, LLC

H-SCALE	V-SCALE	DATE	DESIGNED BY	DRAWN BY	CHECKED BY	REVISION	
						No.	DATE
1"=20'	N/A	12/20/19	SRM	SRM			

**CENTERPLACE TURN LANE IMPROVEMENTS**  
**GRADING & EROSION CONTROL PLAN**  
INTERIM STAGE

SHEET 7 OF 14  
JOB NO. 39722.02



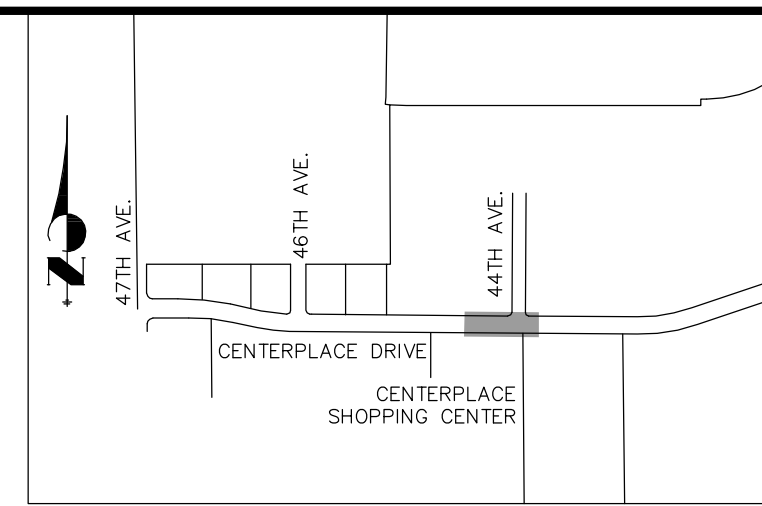

**KEY MAP**  
SCALE: 1"=1000'

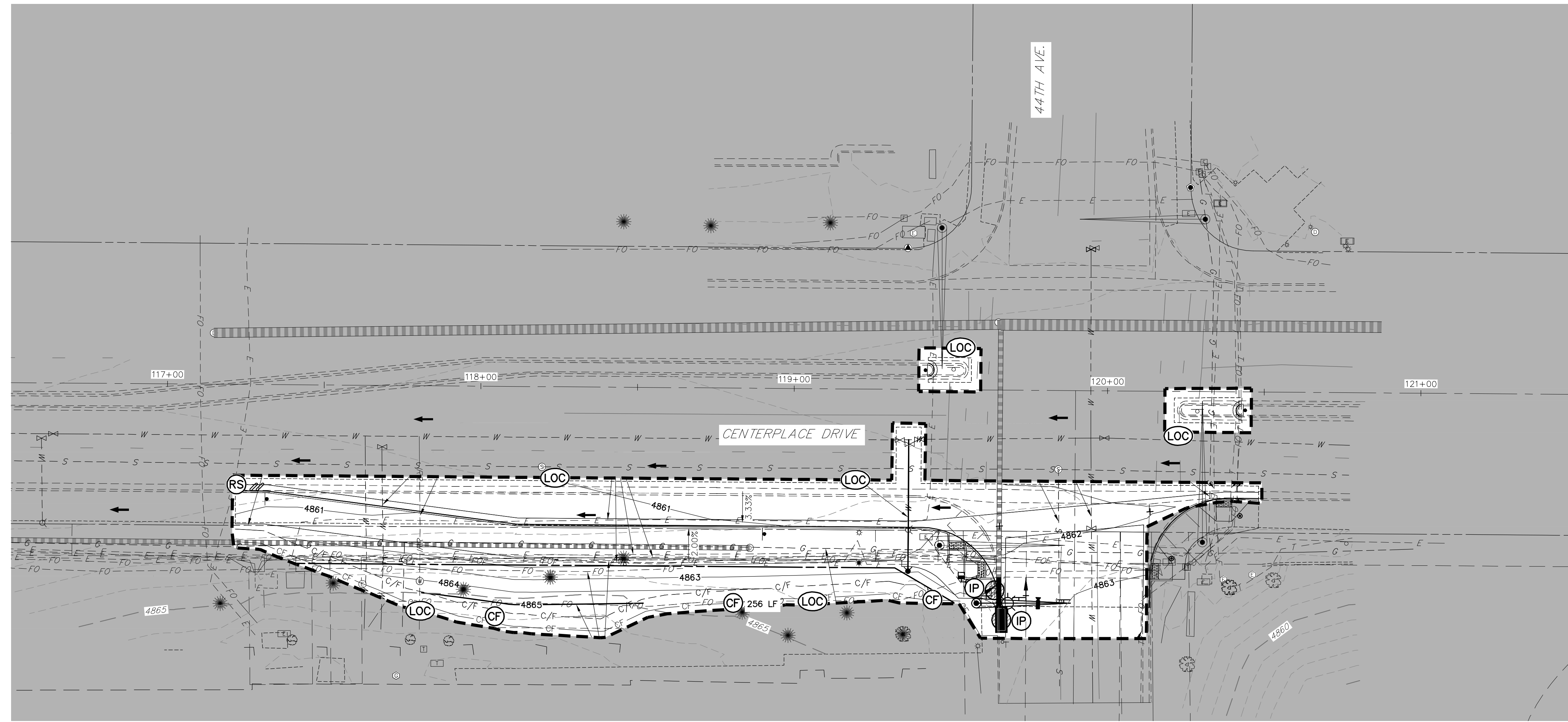

**CENTERPLACE DRIVE**  
STA: 116+50 TO 121+50

**LEGEND**

- |             |   |                  |                          |
|-------------|---|------------------|--------------------------|
| (SF) — SF — | SILT FENCE  | --- C/F ---      | PROPOSED CUT & FILL LINE |
| (CF) — CF — | CONSTRUCTION FENCE  | - - - 5080 - - - | EXISTING INDEX CONTOUR   |
| (IP) (OP)   | STORM DRAIN INLET PROTECTION<br>STORM DRAIN OUTLET PROTECTION | ---              | EXISTING CONTOUR         |
| (LS)        | LANDSCAPE RESTORATION   | — 5080 —         | PROPOSED INDEX CONTOUR   |
| (CWA)       | CONCRETE WASHOUT AREA   | ---              | PROPOSED CONTOUR         |
| (SCL)       | SEDIMENT CONTROL LOG  | (SB)             | SEDIMENT BASIN           |
| ←           | DRAINAGE DIRECTION  | (ECB)            | EROSION CONTROL BLANKET  |
| ---         | PROPOSED ROW  | (VTC)            | VEHICLE TRACKING CONTROL |
| - - -       | PROPOSED EASEMENT   | (SSA)            | STABILIZED STAGING AREA  |
| --- LOC --- | LIMITS OF CONSTRUCTION  | (DD)             | DIVERSION DITCH          |
|             |   | (RS)             | ROCK SOCK                |

**NOTES**

1. INSTALL EROSION/SEDIMENT CONTROL ONLY DURING APPROPRIATE PHASING, AND AS APPROVED BY THE ENGINEER. HOWEVER, INLET PROTECTION SHALL BE INSTALLED IMMEDIATELY AFTER CONSTRUCTION OF NEW INLETS.
2. SECTION 13 OF THE CITY OF GREELEY DESIGN STANDARDS AND CONSTRUCTION SPECIFICATIONS SHALL APPLY FOR ALL EXCAVATION AND EMBANKMENT AREAS. THE ROADWAY SUBGRADE MATERIALS SHALL BE FREE OF ORGANIC MATERIALS AND OTHER DELETERIOUS MATERIALS AND SHALL BE THOROUGHLY SCARIFIED, AND WELL MIXED.
3. CONTRACTOR MAY INSTALL SILT FENCE TO RIGHT-OF-WAY OR TEMPORARY CONSTRUCTION EASEMENT.
4. THE CONTRACTOR SHALL FIND AN APPROPRIATE LOCATION TO SET UP CONCRETE WASHOUT AREA, VEHICLE TRACKING CONTROL, AND STABILIZED STAGING AREA AND SUBMIT TO THE CITY FOR APPROVAL.
5. THE TOTAL DISTURBANCE AREA IS 0.76AC. NO STATE PERMIT OR STORM WATER MANAGEMENT PLAN ARE REQUIRED.

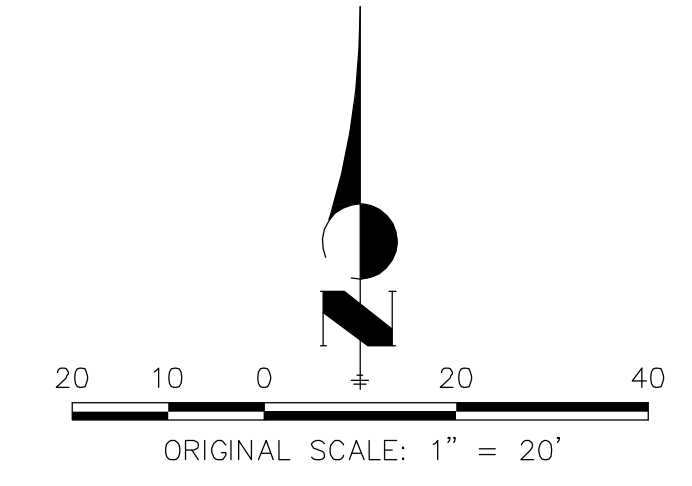

**ENGINEER'S STATEMENT**

PREPARED UNDER MY SUPERVISION

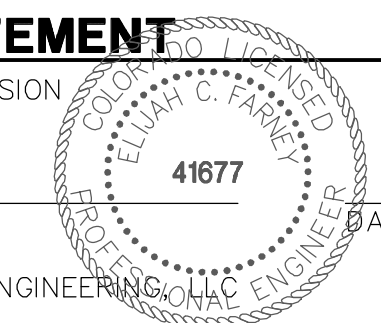

ELJUAH C. FARNEY, P.E.  
COLORADO P.E. 41677  
FOR AND ON BEHALF OF JR ENGINEERING, LLC

CENTERPLACE TURN LANE IMPROVEMENTS	1" = 20'		DESIGNED BY SRM	CHECKED BY SRM
	H-SCALE	V-SCALE		
GRADING & EROSION CONTROL PLAN	DATE	12/20/19	DRAWN BY SRM	SRM
INTERIM STAGE				
SHEET 8 OF 14		JOB NO. 39722.02		

UNTIL SUCH TIME AS THESE DRAWINGS ARE APPROVED BY THE APPROPRIATE REVIEWING AGENCIES, JR ENGINEERING APPROVES THEIR USES AS DESIGNATED BY WRITTEN AUTHORIZATION.

PREPARED FOR  
**BRIAN WARD**  
CITY OF GREELEY—PUBLIC WORKS  
1001 9TH AVENUE  
GREELEY, CO 80631  
(970) 350-9792

**J.R. ENGINEERING**  
A Westrian Company  
Central 303-740-9883 • Colorado Springs 719-588-2583  
Fort Collins 970-491-9888 • www.jrengineering.com

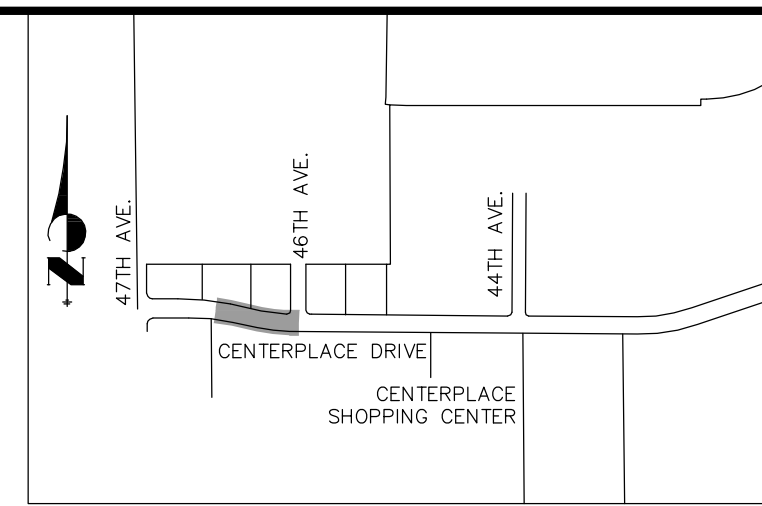
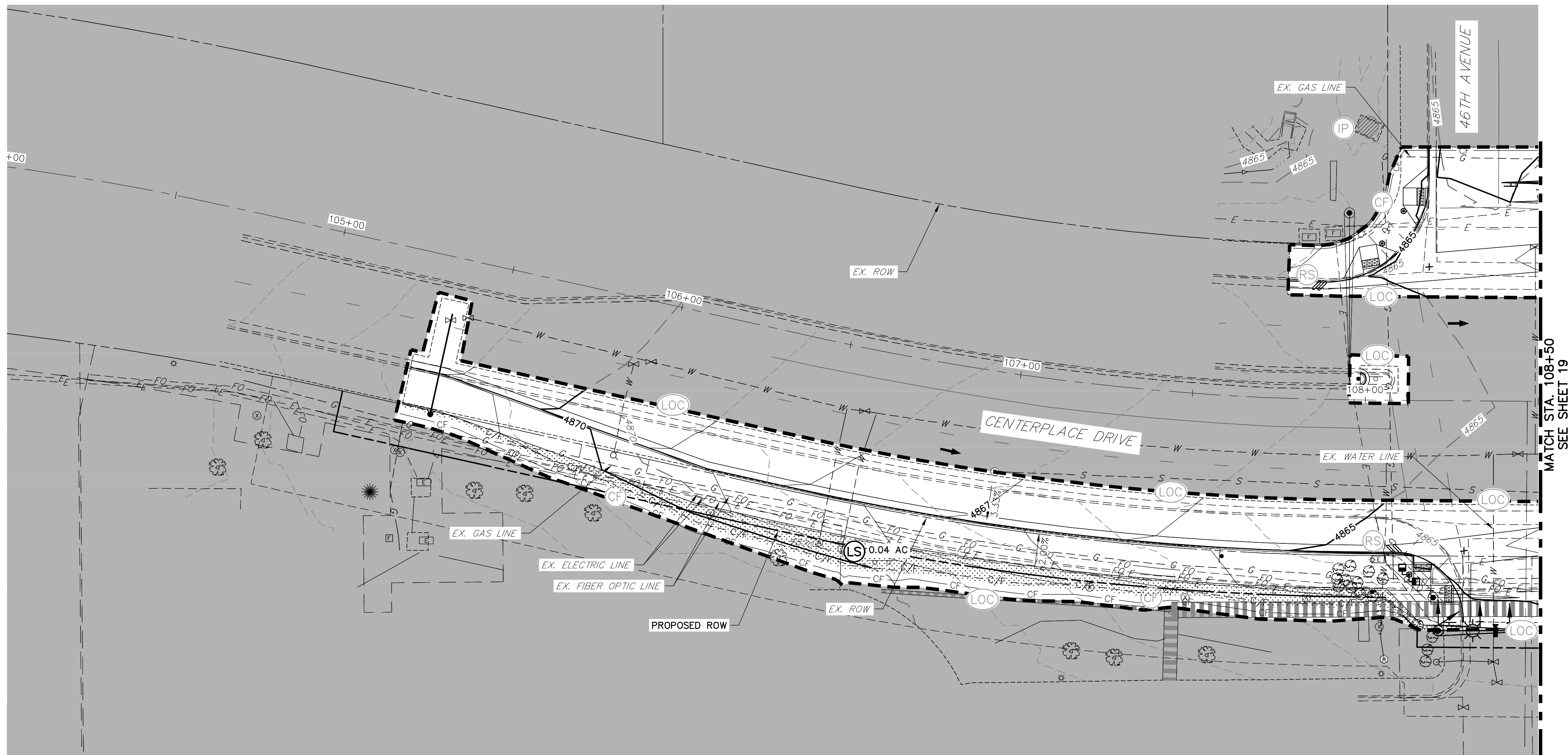

KEY MAP  
SCALE: 1"=1000'

**CENTERPLACE DRIVE**  
STA: 104+00 TO 108+50

**LEGEND**

(SF) — SF — SILT FENCE	--- C/F --- PROPOSED CUT & FILL LINE
(CF) — CF — CONSTRUCTION FENCE	--- 5080 --- EXISTING INDEX CONTOUR
(IP) (S) STORM DRAIN INLET PROTECTION	--- --- EXISTING CONTOUR
(OP) (S) STORM DRAIN OUTLET PROTECTION	--- 5080 --- PROPOSED INDEX CONTOUR
(LS) LANDSCAPE RESTORATION	--- --- PROPOSED CONTOUR
(CWA) CONCRETE WASHOUT AREA	(SB) SEDIMENT BASIN
(SCL) SEDIMENT CONTROL LOG	(ECB) EROSION CONTROL BLANKET
← DRAINAGE DIRECTION	(VTC) VEHICLE TRACKING CONTROL
--- PROPOSED ROW	(SSA) STABILIZED STAGING AREA
--- PROPOSED EASEMENT	(DD) DIVERSION DITCH
--- LOC --- LIMITS OF CONSTRUCTION	(RS) ROCK SOCK

- NOTES**
1. INSTALL EROSION/SEDIMENT CONTROL ONLY DURING APPROPRIATE PHASING, AND AS APPROVED BY THE ENGINEER. HOWEVER, INLET PROTECTION SHALL BE INSTALLED IMMEDIATELY AFTER CONSTRUCTION OF NEW INLETS.
  2. SECTION 13 OF THE CITY OF GREELEY DESIGN STANDARDS AND CONSTRUCTION SPECIFICATIONS SHALL APPLY FOR ALL EXCAVATION AND EMBANKMENT AREAS. THE ROADWAY SUBGRADE MATERIALS SHALL BE FREE OF ORGANIC MATERIALS AND OTHER DELETERIOUS MATERIALS AND SHALL BE THOROUGHLY SCARIFIED, AND WELL MIXED.
  3. CONTRACTOR MAY INSTALL SILT FENCE TO RIGHT-OF-WAY OR TEMPORARY CONSTRUCTION EASEMENT.
  4. THE CONTRACTOR SHALL FIND AN APPROPRIATE LOCATION TO SET UP CONCRETE WASHOUT AREA, VEHICLE TRACKING CONTROL, AND STABILIZED STAGING AREA AND SUBMIT TO THE CITY FOR APPROVAL.
  5. THE TOTAL DISTURBANCE AREA IS 0.76AC. NO STATE PERMIT OR STORM WATER MANAGEMENT PLAN ARE REQUIRED.

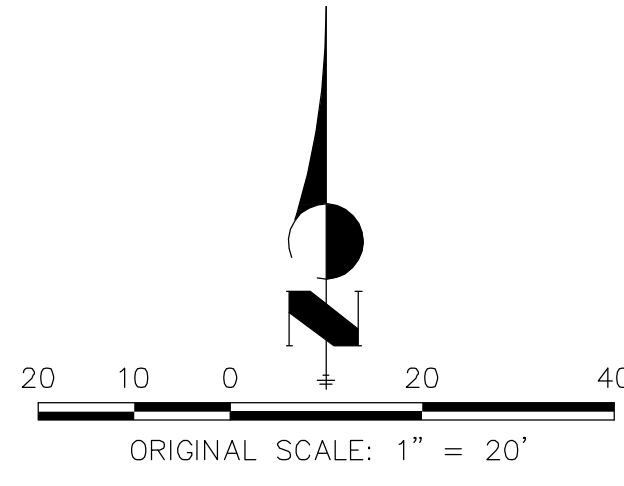

**ENGINEER'S STATEMENT**

PREPARED UNDER MY SUPERVISION  
ELIJAH C. FARNEY, P.E.  
COLORADO P.E. 41677  
FOR AND ON BEHALF OF JR ENGINEERING, LLC

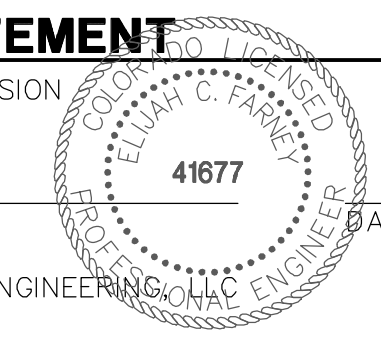

CENTERPLACE TURN LANE IMPROVEMENTS	DESIGNED BY SRM	12/20/19	1"=20'	No.	REVISION	BY	DATE
GRADING & EROSION CONTROL PLAN	DRAWN BY SRM		V-SCALE N/A				
FINAL STAGE	CHECKED BY		DATE				
SHEET 9 OF 14							
JOB NO. 39722.02							

UNTIL SUCH TIME AS THESE DRAWINGS ARE APPROVED BY THE APPROPRIATE REVIEWING AGENCIES, JR ENGINEERING APPROVES THEIR USES AS DESIGNATED BY WRITTEN AUTHORIZATION.

PREPARED FOR  
**BRIAN WARD**  
CITY OF GREELEY—PUBLIC WORKS  
1001 9TH AVENUE  
GREELEY, CO 80631  
(970) 350-9792

**J.R. ENGINEERING**  
A WestJan Company  
Central 303-740-9888 • Colorado Springs 719-588-2683  
Fort Collins 970-491-9888 • www.jrengineering.com

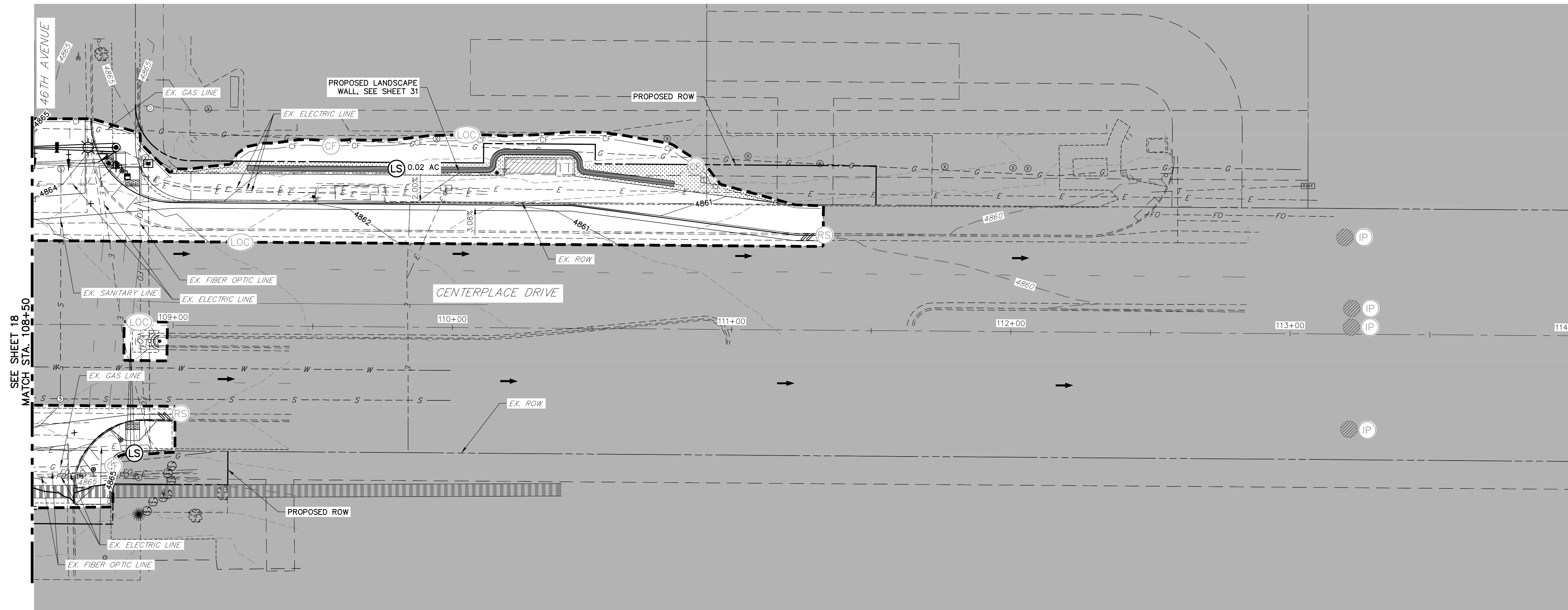
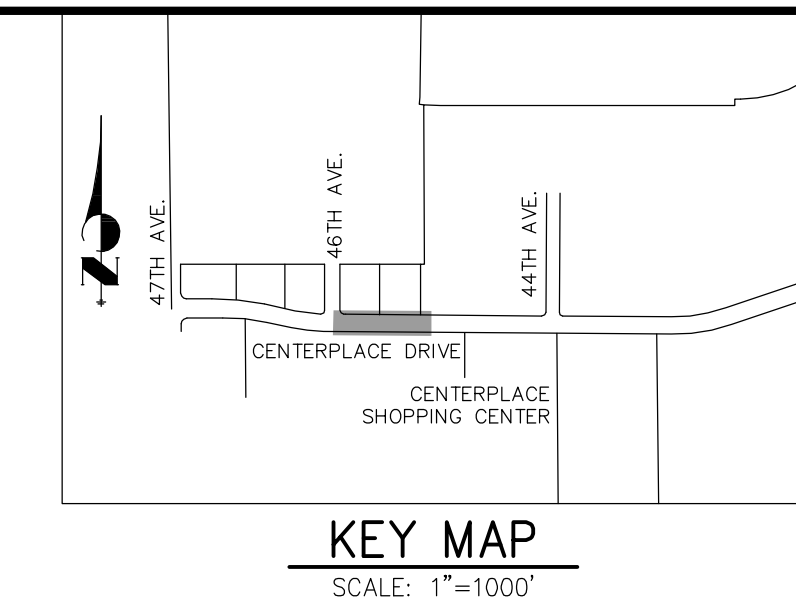

**CENTERPLACE DRIVE**  
STA: 108+50 TO 114+00

LEGEND	
(SF) — SF —	SILT FENCE
(CF) — CF —	CONSTRUCTION FENCE
(P) (OP)	STORM DRAIN INLET PROTECTION
(OP)	STORM DRAIN OUTLET PROTECTION
(LS)	LANDSCAPE RESTORATION
(CWA)	CONCRETE WASHOUT AREA
(SCL)	SEDIMENT CONTROL LOG
(Arrow)	DRAINAGE DIRECTION
(Dashed line)	PROPOSED ROW
(Dotted line)	PROPOSED EASEMENT
(LOC)	LIMITS OF CONSTRUCTION
(C/F)	PROPOSED CUT & FILL LINE
(5080)	EXISTING INDEX CONTOUR
(5080)	EXISTING CONTOUR
(5080)	PROPOSED INDEX CONTOUR
(5080)	PROPOSED CONTOUR
(SB)	SEDIMENT BASIN
(ECB)	EROSION CONTROL BLANKET
(VTC)	VEHICLE TRACKING CONTROL
(SSA)	STABILIZED STAGING AREA
(DD)	DIVERSION DITCH
(RS)	ROCK SOCK

- NOTES**
- INSTALL EROSION/SEDIMENT CONTROL ONLY DURING APPROPRIATE PHASING, AND AS APPROVED BY THE ENGINEER. HOWEVER, INLET PROTECTION SHALL BE INSTALLED IMMEDIATELY AFTER CONSTRUCTION OF NEW INLETS.
  - SECTION 13 OF THE CITY OF GREELEY DESIGN STANDARDS AND CONSTRUCTION SPECIFICATIONS SHALL APPLY FOR ALL EXCAVATION AND EMBANKMENT AREAS. THE ROADWAY SUBGRADE MATERIALS SHALL BE FREE OF ORGANIC MATERIALS AND OTHER DELETERIOUS MATERIALS AND SHALL BE THOROUGHLY SCARIFIED, AND WELL MIXED.
  - CONTRACTOR MAY INSTALL SILT FENCE TO RIGHT-OF-WAY OR TEMPORARY CONSTRUCTION EASEMENT.
  - THE CONTRACTOR SHALL FIND AN APPROPRIATE LOCATION TO SET UP CONCRETE WASHOUT AREA, VEHICLE TRACKING CONTROL, AND STABILIZED STAGING AREA AND SUBMIT TO THE CITY FOR APPROVAL.
  - THE TOTAL DISTURBANCE AREA IS 0.76AC. NO STATE PERMIT OR STORM WATER MANAGEMENT PLAN ARE REQUIRED.

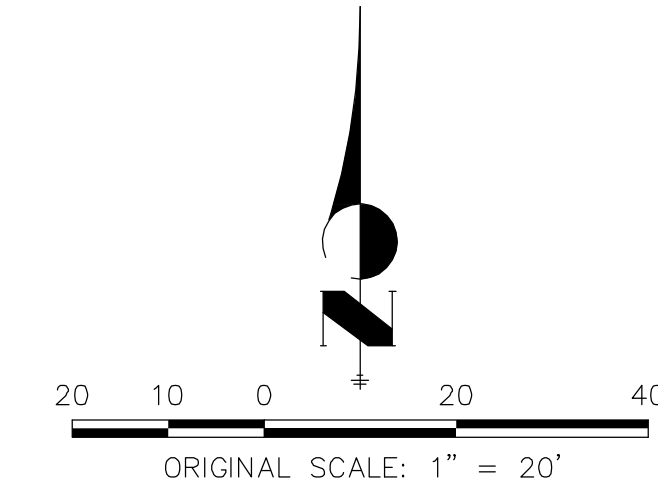

**ENGINEER'S STATEMENT**  
PREPARED UNDER MY SUPERVISION

ELIJAH C. FARNEY, P.E.  
COLORADO P.E. 41677

FOR AND ON BEHALF OF JR ENGINEERING, LLC

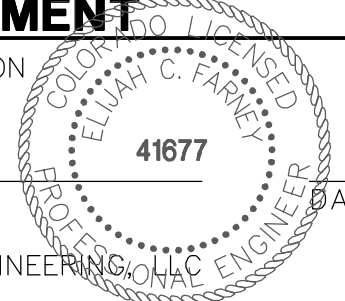

<b>CENTERPLACE TURN LANE IMPROVEMENTS</b>  <b>GRADING &amp; EROSION CONTROL PLAN</b>  <b>FINAL STAGE</b>	H-SCALE: 1"=20' V-SCALE: N/A DATE: 12/20/19 DESIGNED BY: SRM DRAWN BY: SRM CHECKED BY:	No. REVISION <table border="1"> <tr><td> </td><td> </td></tr> <tr><td> </td><td> </td></tr> <tr><td> </td><td> </td></tr> <tr><td> </td><td> </td></tr> </table>									BY:    DATE:
PREPARED FOR <b>BRIAN WARD</b> CITY OF GREELEY-PUBLIC WORKS 1001 9TH AVENUE GREELEY, CO 80631 (970) 350-9792	J.R. ENGINEERING A Westman Company  Centennial 303-740-9888 • Colorado Springs 719-588-2583 Fort Collins 970-491-9888 • www.jrengineering.com	UNTIL SUCH TIME AS THESE DRAWINGS ARE APPROVED BY THE APPROPRIATE REVIEWING AGENCIES, JR ENGINEERING APPROVES THEIR USE. USES DESIGNATED BY WRITTEN AUTHORIZATION.	SCALE: 1"=1000'								
SHEET <b>10</b> OF <b>14</b> JOB NO. <b>39722.02</b>											

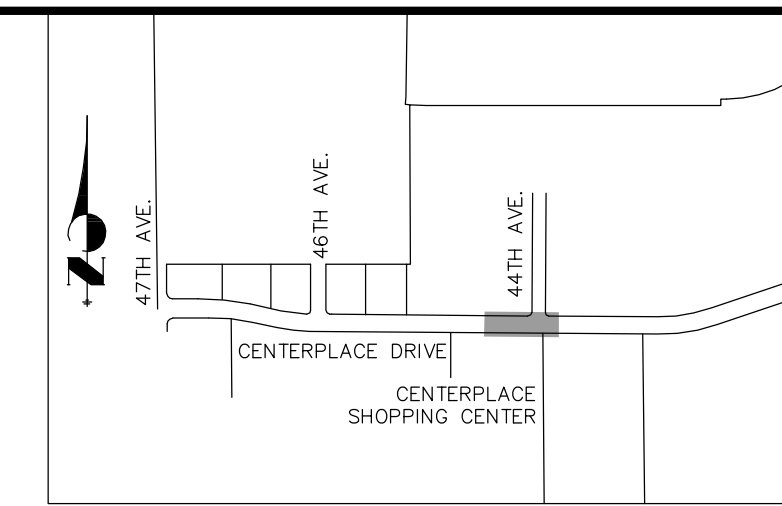

KEY MAP  
SCALE: 1"=1000'

UNTIL SUCH TIME AS THESE DRAWINGS ARE APPROVED BY THE APPROPRIATE REVIEWING AGENCIES, JR ENGINEERING APPROVES THEIR USE. THESE DRAWINGS ARE DESIGNATED BY WRITTEN AUTHORIZATION.

PREPARED FOR  
**BRIAN WARD**  
CITY OF GREELEY—PUBLIC WORKS  
1001 9TH AVENUE  
GREELEY, CO 80631  
(970) 350-9792

**J.R. ENGINEERING**  
A Westman Company  
Central 303-740-9883 • Colorado Springs 719-588-2583  
Fort Collins 970-491-9888 • www.jrengineering.com

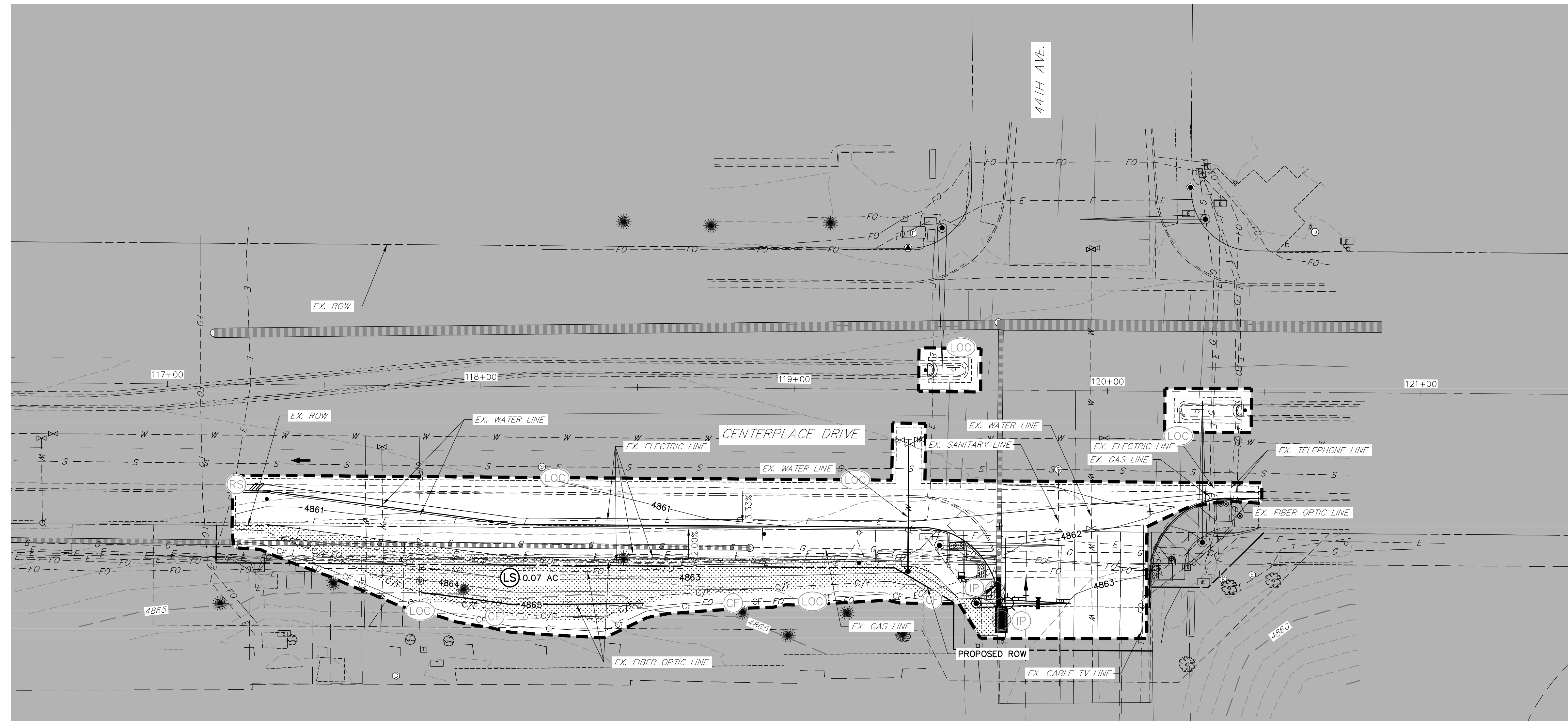

**CENTERPLACE DRIVE**  
STA: 116+50 TO 121+50

(SF)	— SF —	SILT FENCE	---	C/F	PROPOSED CUT & FILL LINE
(CF)	— CF —	CONSTRUCTION FENCE	---	5080	EXISTING INDEX CONTOUR
(IP)	⊙	STORM DRAIN INLET PROTECTION	---		EXISTING CONTOUR
(OP)	⊙	STORM DRAIN OUTLET PROTECTION	---	5080	PROPOSED INDEX CONTOUR
(LS)	⊙	LANDSCAPE RESTORATION	---		PROPOSED CONTOUR
(CWA)	⊠	CONCRETE WASHOUT AREA	(SB)		SEDIMENT BASIN
(SCL)	⊠	SEDIMENT CONTROL LOG	(ECB)		EROSION CONTROL BLANKET
	→	DRAINAGE DIRECTION	(VTC)		VEHICLE TRACKING CONTROL
	---	PROPOSED ROW	(SSA)		STABILIZED STAGING AREA
	---	PROPOSED EASEMENT	(DD)		DIVERSION DITCH
	--- LOC ---	LIMITS OF CONSTRUCTION	(RS)		ROCK SOCK

- NOTES**
1. INSTALL EROSION/SEDIMENT CONTROL ONLY DURING APPROPRIATE PHASING, AND AS APPROVED BY THE ENGINEER. HOWEVER, INLET PROTECTION SHALL BE INSTALLED IMMEDIATELY AFTER CONSTRUCTION OF NEW INLETS.
  2. SECTION 13 OF THE CITY OF GREELEY DESIGN STANDARDS AND CONSTRUCTION SPECIFICATIONS SHALL APPLY FOR ALL EXCAVATION AND EMBANKMENT AREAS. THE ROADWAY SUBGRADE MATERIALS SHALL BE FREE OF ORGANIC MATERIALS AND OTHER DELETERIOUS MATERIALS AND SHALL BE THOROUGHLY SCARIFIED, AND WELL MIXED.
  3. CONTRACTOR MAY INSTALL SILT FENCE TO RIGHT-OF-WAY OR TEMPORARY CONSTRUCTION EASEMENT.
  4. THE CONTRACTOR SHALL FIND AN APPROPRIATE LOCATION TO SET UP CONCRETE WASHOUT AREA, VEHICLE TRACKING CONTROL, AND STABILIZED STAGING AREA AND SUBMIT TO THE CITY FOR APPROVAL.
  5. THE TOTAL DISTURBANCE AREA IS 0.76AC. NO STATE PERMIT OR STORM WATER MANAGEMENT PLAN ARE REQUIRED.

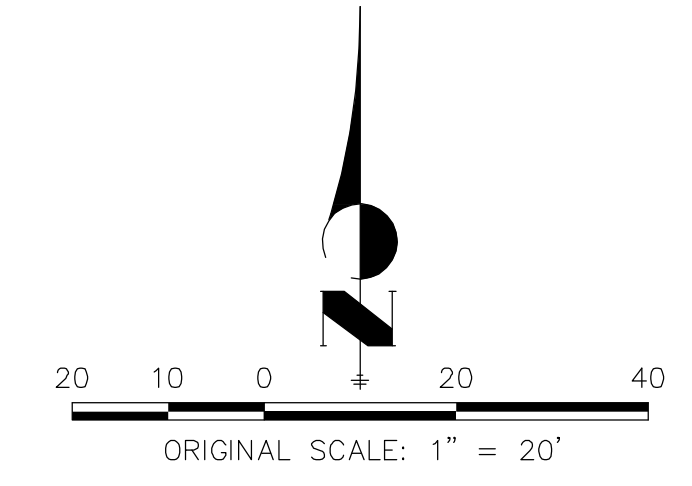

**ENGINEER'S STATEMENT**

PREPARED UNDER MY SUPERVISION  
ELIJAH C. FARNEY, P.E.  
COLORADO P.E. 41677  
FOR AND ON BEHALF OF JR ENGINEERING, LLC  
DATE

CENTERPLACE TURN LANE IMPROVEMENTS	BY	DATE				
	No.	REVISION				
GRADING & EROSION CONTROL PLAN	H-SCALE	1"=20'	N/A	12/20/19	SRM	SRM
	V-SCALE					
FINAL STAGE	DESIGNED BY					
	DRAWN BY					
	CHECKED BY					
	SHEET	11	OF	14		
	JOB NO.	39722.02				



**Concrete Washout Area (CWA)**

**MM-1**

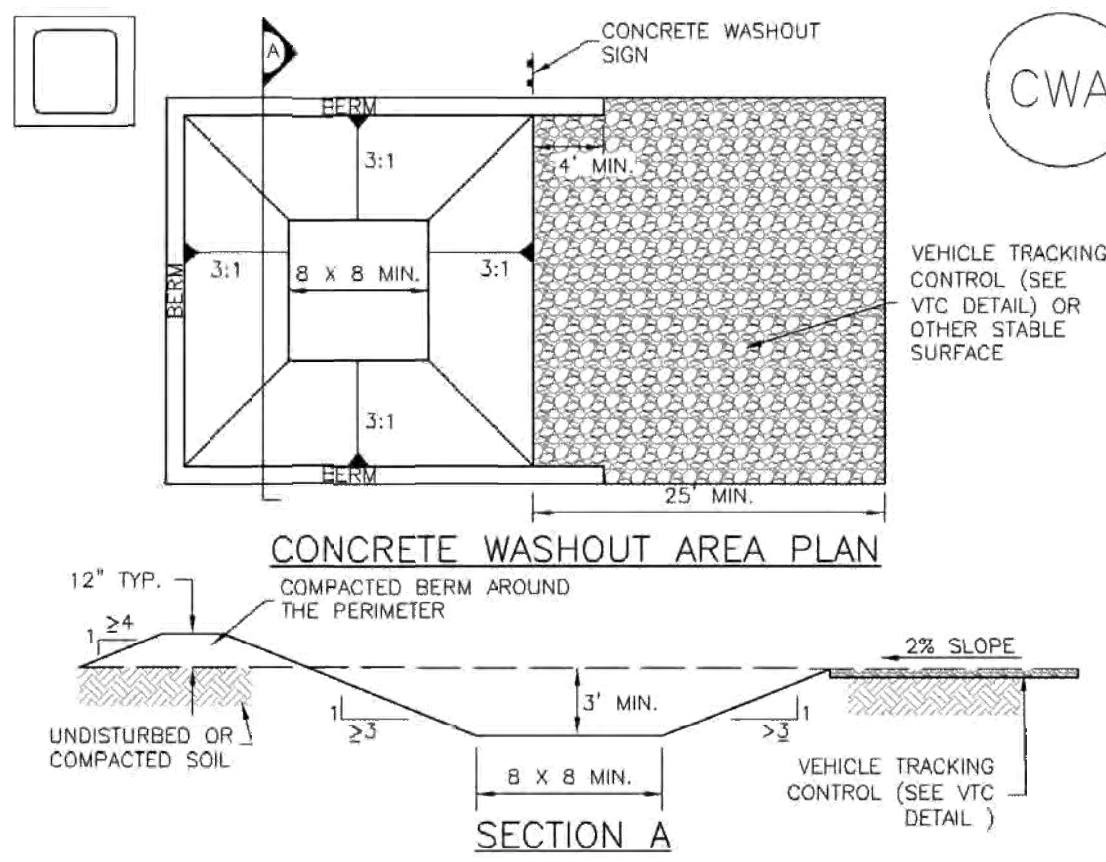

**CWA-1. CONCRETE WASHOUT AREA**

**CWA INSTALLATION NOTES**

- SEE PLAN VIEW FOR:  
-CWA INSTALLATION LOCATION.
- DO NOT LOCATE AN UNLINED CWA WITHIN 400' OF ANY NATURAL DRAINAGE PATHWAY OR WATERBODY. DO NOT LOCATE WITHIN 1,000' OF ANY WELLS OR DRINKING WATER SOURCES. IF SITE CONSTRAINTS MAKE THIS INFASIBLE, OR IF HIGHLY PERMEABLE SOILS EXIST ON SITE, THE CWA MUST BE INSTALLED WITH AN IMPERMEABLE LINER (15 MIL MIN. THICKNESS) OR SURFACE STORAGE ALTERNATIVES USING PREFABRICATED CONCRETE WASHOUT DEVICES OR A LINED ABOVE GROUND STORAGE ARE SHOULD BE USED.
- THE CWA SHALL BE INSTALLED PRIOR TO CONCRETE PLACEMENT ON SITE.
- CWA SHALL INCLUDE A FLAT SUBSURFACE PIT THAT IS AT LEAST 8' BY 8' SLOPES LEADING OUT OF THE SUBSURFACE PIT SHALL BE 3:1 OR FLATTER. THE PIT SHALL BE AT LEAST 3' DEEP.
- BERM SURROUNDING SIDES AND BACK OF THE CWA SHALL HAVE MINIMUM HEIGHT OF 1'.
- VEHICLE TRACKING PAD SHALL BE SLOPED 2% TOWARDS THE CWA.
- SIGNS SHALL BE PLACED AT THE CONSTRUCTION ENTRANCE, AT THE CWA, AND ELSEWHERE AS NECESSARY TO CLEARLY INDICATE THE LOCATION OF THE CWA TO OPERATORS OF CONCRETE TRUCKS AND PUMP RIGS.
- USE EXCAVATED MATERIAL FOR PERIMETER BERM CONSTRUCTION.

November 2010 Urban Drainage and Flood Control District CWA-3  
Urban Storm Drainage Criteria Manual Volume 3

**Silt Fence (SF)**

**SC-1**

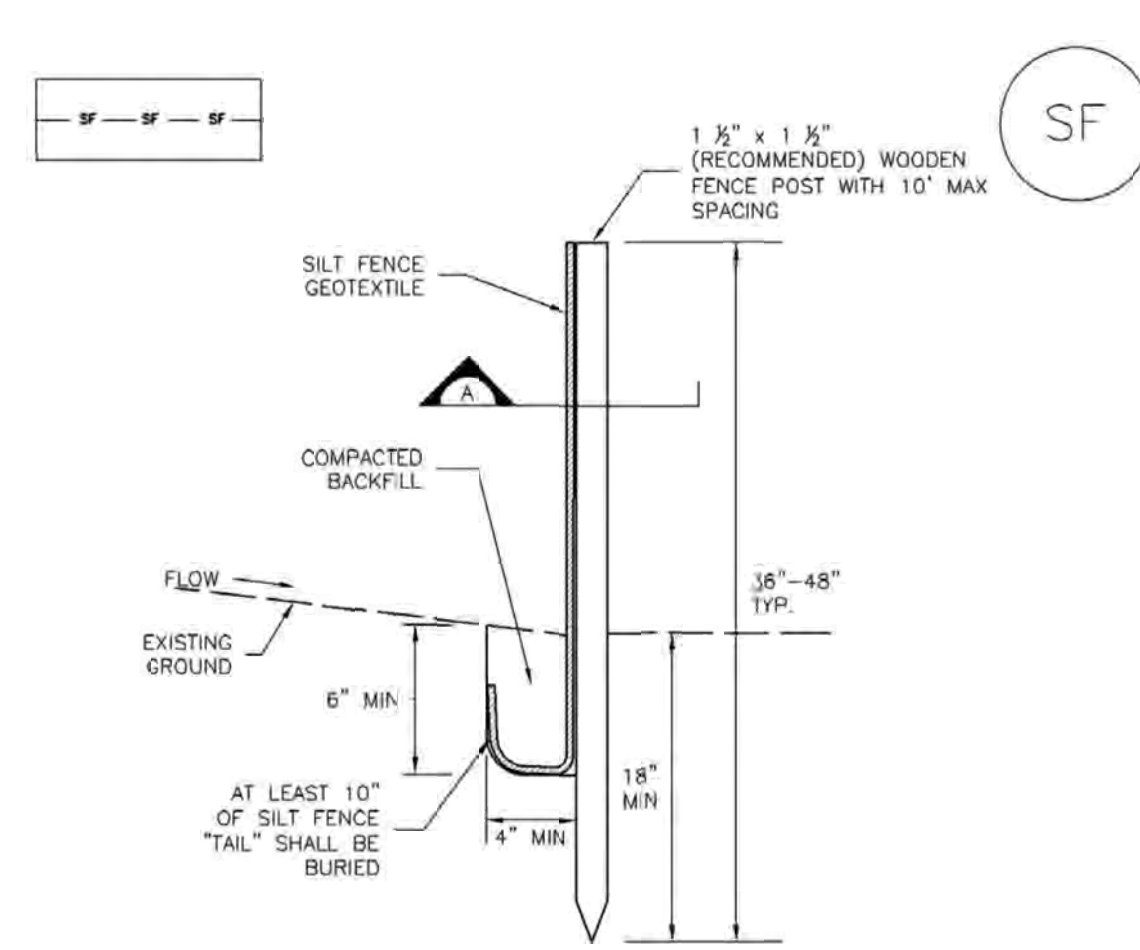

**SILT FENCE**

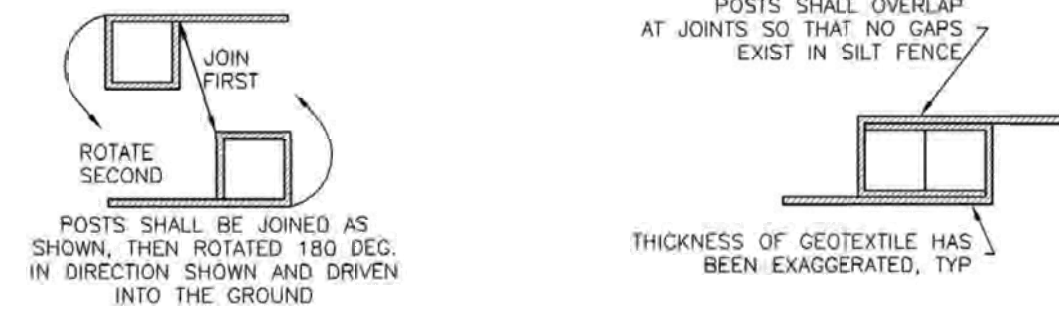

**SECTION A**

**SF-1. SILT FENCE**

November 2010 Urban Drainage and Flood Control District SF-3  
Urban Storm Drainage Criteria Manual Volume 3

**Stabilized Staging Area (SSA)**

**SM-6**

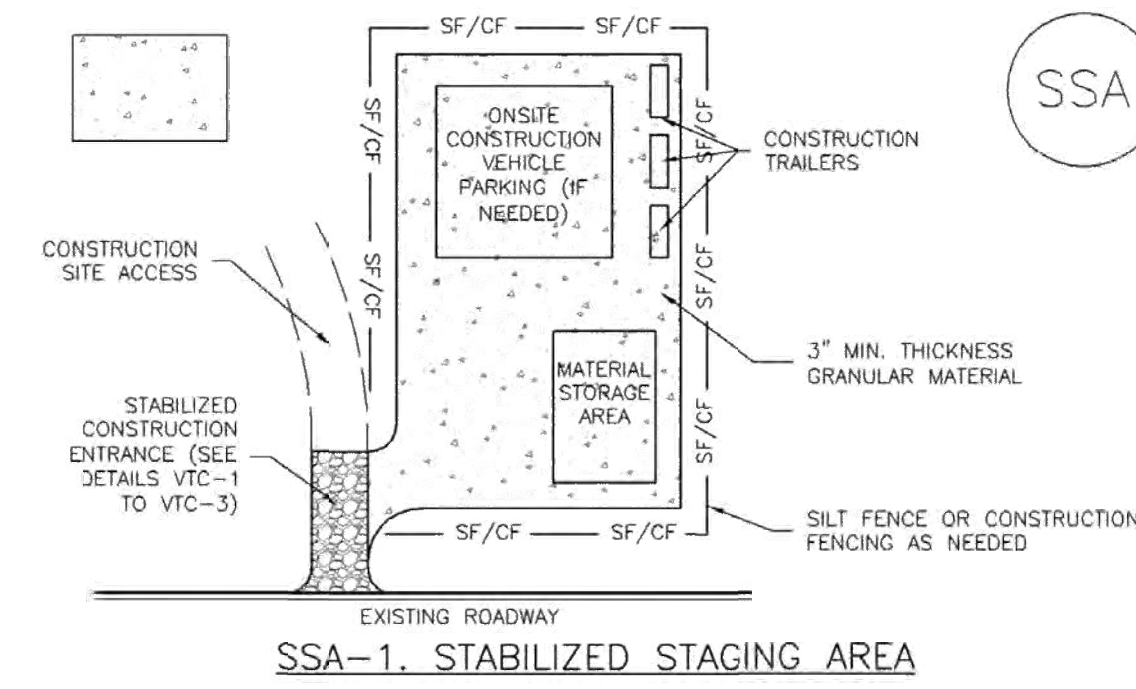

**SSA-1. STABILIZED STAGING AREA**

**STABILIZED STAGING AREA INSTALLATION NOTES**

- SEE PLAN VIEW FOR:  
-LOCATION OF STAGING AREA(S).  
-CONTRACTOR MAY ADJUST LOCATION AND SIZE OF STAGING AREA WITH APPROVAL FROM THE LOCAL JURISDICTION.
- STABILIZED STAGING AREA SHOULD BE APPROPRIATE FOR THE NEEDS OF THE SITE. OVERSIZING RESULTS IN A LARGER AREA TO STABILIZE FOLLOWING CONSTRUCTION.
- STAGING AREA SHALL BE STABILIZED PRIOR TO OTHER OPERATIONS ON THE SITE.
- THE STABILIZED STAGING AREA SHALL CONSIST OF A MINIMUM 3\"/>

**STABILIZED STAGING AREA MAINTENANCE NOTES**

- INSPECT BMPs EACH WORKDAY, AND MAINTAIN THEM IN EFFECTIVE OPERATING CONDITION. MAINTENANCE OF BMPs SHOULD BE PROACTIVE, NOT REACTIVE. INSPECT BMPs AS SOON AS POSSIBLE (AND ALWAYS WITHIN 24 HOURS) FOLLOWING A STORM THAT CAUSES SURFACE EROSION, AND PERFORM NECESSARY MAINTENANCE.
- FREQUENT OBSERVATIONS AND MAINTENANCE ARE NECESSARY TO MAINTAIN BMPs IN EFFECTIVE OPERATING CONDITION. INSPECTIONS AND CORRECTIVE MEASURES SHOULD BE DOCUMENTED THOROUGHLY.
- WHERE BMPs HAVE FAILED, REPAIR OR REPLACEMENT SHOULD BE INITIATED UPON DISCOVERY OF THE FAILURE.
- ROCK SHALL BE REAPPLIED OR REGRADED AS NECESSARY IF RUTTING OCCURS OR UNDERLYING SUBGRADE BECOMES EXPOSED.

November 2010 Urban Drainage and Flood Control District SSA-3  
Urban Storm Drainage Criteria Manual Volume 3

**MM-1 Concrete Washout Area (CWA)**

**CWA MAINTENANCE NOTES**

- INSPECT BMPs EACH WORKDAY, AND MAINTAIN THEM IN EFFECTIVE OPERATING CONDITION. MAINTENANCE OF BMPs SHOULD BE PROACTIVE, NOT REACTIVE. INSPECT BMPs AS SOON AS POSSIBLE (AND ALWAYS WITHIN 24 HOURS) FOLLOWING A STORM THAT CAUSES SURFACE EROSION, AND PERFORM NECESSARY MAINTENANCE.
- FREQUENT OBSERVATIONS AND MAINTENANCE ARE NECESSARY TO MAINTAIN BMPs IN EFFECTIVE OPERATING CONDITION. INSPECTIONS AND CORRECTIVE MEASURES SHOULD BE DOCUMENTED THOROUGHLY.
- WHERE BMPs HAVE FAILED, REPAIR OR REPLACEMENT SHOULD BE INITIATED UPON DISCOVERY OF THE FAILURE.
- THE CWA SHALL BE REPAIRED, CLEANED, OR ENLARGED AS NECESSARY TO MAINTAIN CAPACITY FOR CONCRETE WASTE. CONCRETE MATERIALS, ACCUMULATED IN PIT, SHALL BE REMOVED ONCE THE MATERIALS HAVE REACHED A DEPTH OF 2\"/>

CWA-4 Urban Drainage and Flood Control District November 2010  
Urban Storm Drainage Criteria Manual Volume 3

**SC-1 Silt Fence (SF)**

**SILT FENCE INSTALLATION NOTES**

- SILT FENCE MUST BE PLACED AWAY FROM THE TOE OF THE SLOPE TO ALLOW FOR WATER PONDING. SILT FENCE AT THE TOE OF A SLOPE SHOULD BE INSTALLED IN A FLAT LOCATION AT LEAST SEVERAL FEET (2-5 FT) FROM THE TOE OF THE SLOPE TO ALLOW ROOM FOR PONDING AND DEPOSITION.
- A UNIFORM 6\"/>

**SILT FENCE MAINTENANCE NOTES**

- INSPECT BMPs EACH WORKDAY, AND MAINTAIN THEM IN EFFECTIVE OPERATING CONDITION. MAINTENANCE OF BMPs SHOULD BE PROACTIVE, NOT REACTIVE. INSPECT BMPs AS SOON AS POSSIBLE (AND ALWAYS WITHIN 24 HOURS) FOLLOWING A STORM THAT CAUSES SURFACE EROSION, AND PERFORM NECESSARY MAINTENANCE.
- FREQUENT OBSERVATIONS AND MAINTENANCE ARE NECESSARY TO MAINTAIN BMPs IN EFFECTIVE OPERATING CONDITION. INSPECTIONS AND CORRECTIVE MEASURES SHOULD BE DOCUMENTED THOROUGHLY.
- WHERE BMPs HAVE FAILED, REPAIR OR REPLACEMENT SHOULD BE INITIATED UPON DISCOVERY OF THE FAILURE.
- SEDIMENT ACCUMULATED UPSTREAM OF THE SILT FENCE SHALL BE REMOVED AS NEEDED TO MAINTAIN THE FUNCTIONALITY OF THE BMP, TYPICALLY WHEN DEPTH OF ACCUMULATED SEDIMENTS IS APPROXIMATELY 6\"/>

SF-4 Urban Drainage and Flood Control District November 2010  
Urban Storm Drainage Criteria Manual Volume 3

**SM-6 Stabilized Staging Area (SSA)**

**STABILIZED STAGING AREA MAINTENANCE NOTES**

- STABILIZED STAGING AREA SHALL BE ENLARGED IF NECESSARY TO CONTAIN PARKING, STORAGE, AND UNLOADING/LOADING OPERATIONS.
- THE STABILIZED STAGING AREA SHALL BE REMOVED AT THE END OF CONSTRUCTION. THE GRANULAR MATERIAL SHALL BE REMOVED OR, IF APPROVED BY THE LOCAL JURISDICTION, USED ON SITE, AND THE AREA COVERED WITH TOPSOIL, SEEDED AND MULCHED OR OTHERWISE STABILIZED IN A MANNER APPROVED BY LOCAL JURISDICTION.

SSA-4 Urban Drainage and Flood Control District November 2010  
Urban Storm Drainage Criteria Manual Volume 3

UNTIL SUCH TIME AS THESE DRAWINGS ARE APPROVED BY THE APPROPRIATE REVIEWING AGENCIES, OR ENGINEERING APPROVES THEIR USE, THESE DRAWINGS ARE DESIGNATED BY WRITTEN AUTHORIZATION.

PREPARED FOR  
**BRIAN WARD**  
CITY OF GREELEY-PUBLIC WORKS  
1001 9TH AVENUE  
GREELEY, CO 80631  
(970) 350-9792

**J.R. ENGINEERING**  
A Westrain Company  
Central 303-740-9883 • Colorado Springs 719-588-2593  
Fort Collins 970-491-9888 • www.jrengineering.com

BY	DATE	REVISION

H-SCALE	N/A	V-SCALE	N/A	DATE	DESIGNED BY	DRAWN BY	CHECKED BY
				12/20/19	N/A	MJP	

CENTERPLACE TURN LANE IMPROVEMENTS  
DETAIL SHEETS

SHEET 12 OF 14  
JOB NO. 39722.02





**SC-5 Rock Sock (RS)**

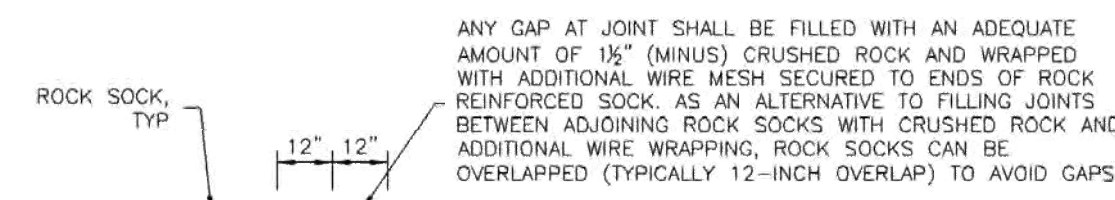
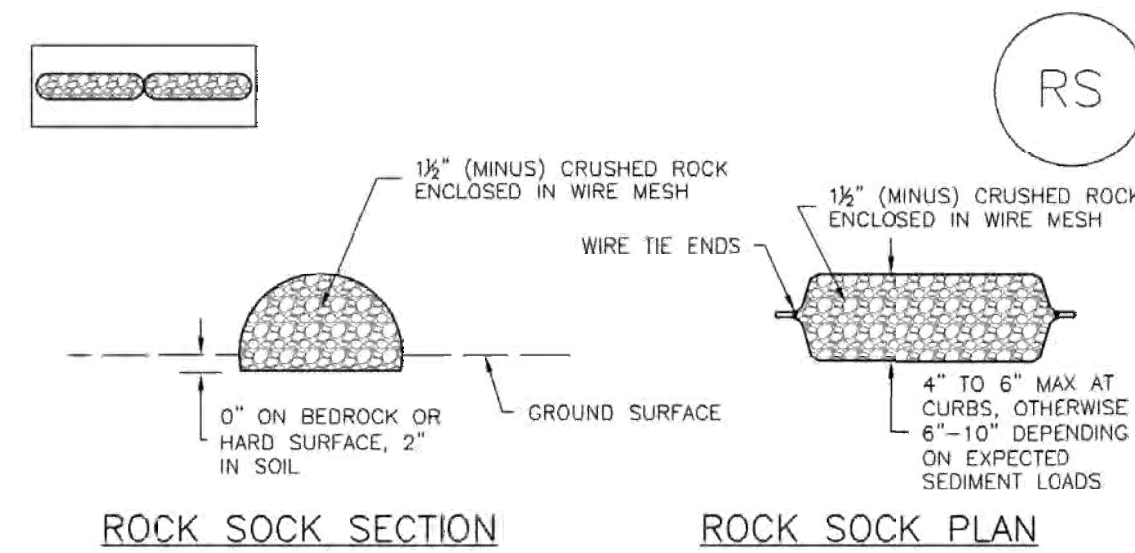

GRADATION TABLE	
SIEVE SIZE	MASS PERCENT PASSING SQUARE MESH SIEVES
NO. 4	
2"	100
1 1/2"	90 - 100
1"	20 - 55
3/4"	0 - 15
3/8"	0 - 5

**ROCK SOCK JOINTING**

**ROCK SOCK INSTALLATION NOTES**

- SEE PLAN VIEW FOR LOCATION(S) OF ROCK SOCKS.
- CRUSHED ROCK SHALL BE 1/2" (MINUS) IN SIZE WITH A FRACTURED FACE (ALL SIDES) AND SHALL COMPLY WITH GRADATION SHOWN ON THIS SHEET (1/2" MINUS).
- WIRE MESH SHALL BE FABRICATED OF 10 GAGE POULTRY MESH, OR EQUIVALENT, WITH A MAXIMUM OPENING OF 1/2", RECOMMENDED MINIMUM ROLL WIDTH OF 48"
- WIRE MESH SHALL BE SECURED USING "HOG RINGS" OR WIRE TIES AT 6" CENTERS ALONG ALL JOINTS AND AT 2" CENTERS ON ENDS OF SOCKS.
- SOME MUNICIPALITIES MAY ALLOW THE USE OF FILTER FABRIC AS AN ALTERNATIVE TO WIRE MESH FOR THE ROCK ENCLOSURE.

**RS-1. ROCK SOCK PERIMETER CONTROL**

RS-2 Urban Drainage and Flood Control District November 2010  
Urban Storm Drainage Criteria Manual Volume 3

**Vehicle Tracking Control (VTC) SM-4**

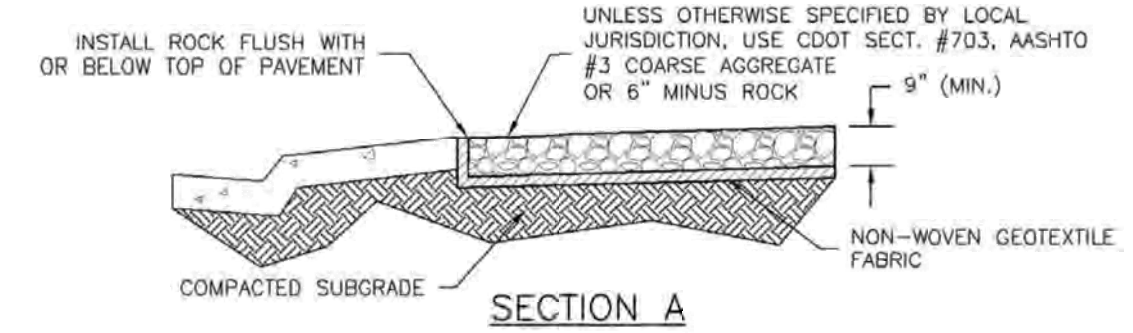
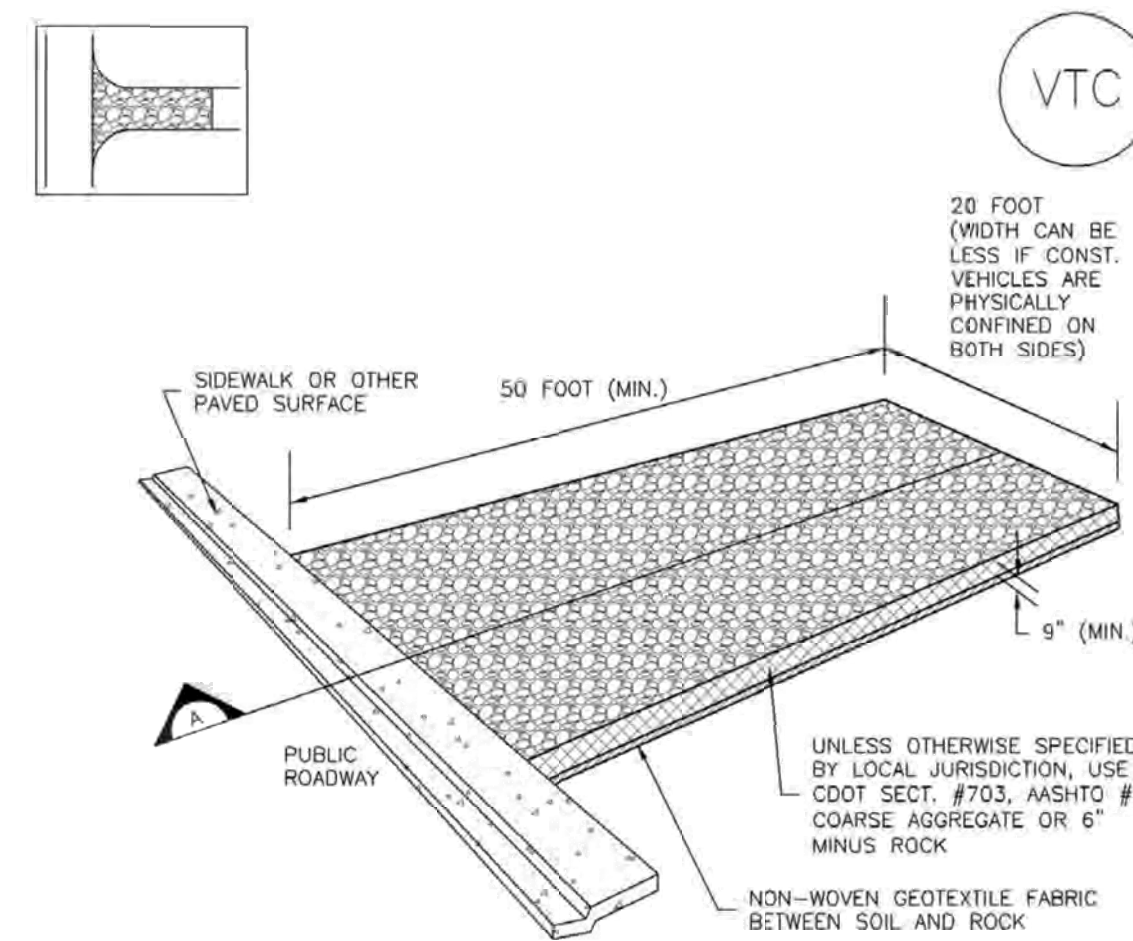

**VTC-1. AGGREGATE VEHICLE TRACKING CONTROL**

November 2010 Urban Drainage and Flood Control District VTC-3  
Urban Storm Drainage Criteria Manual Volume 3

**Vehicle Tracking Control (VTC) SM-4**

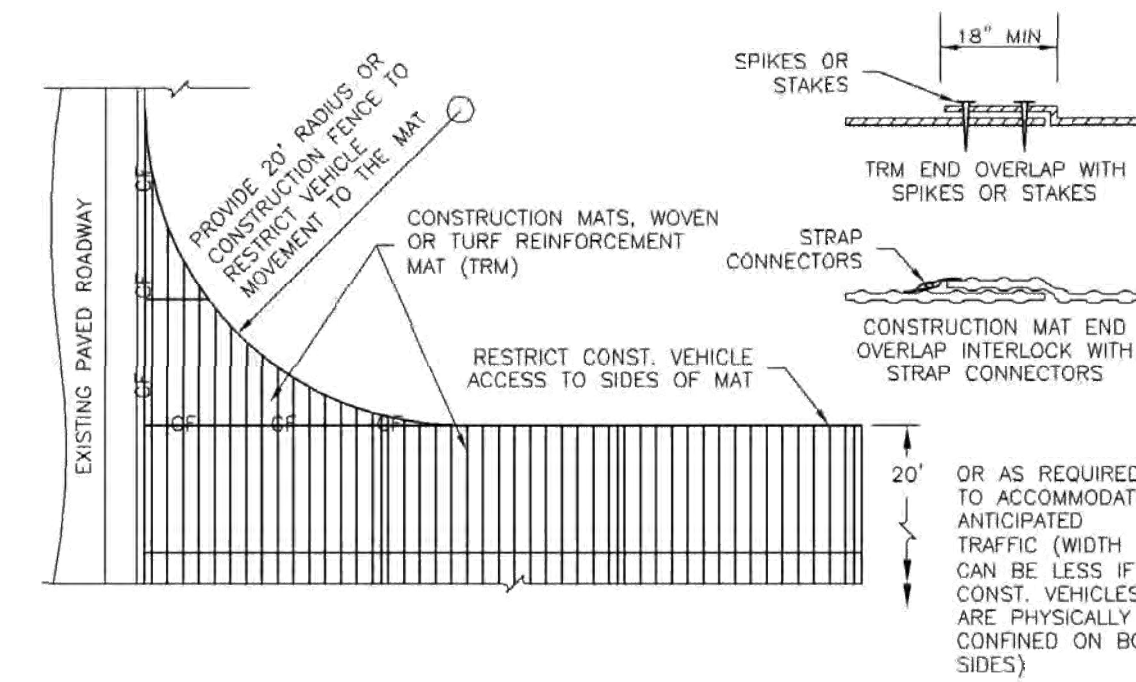
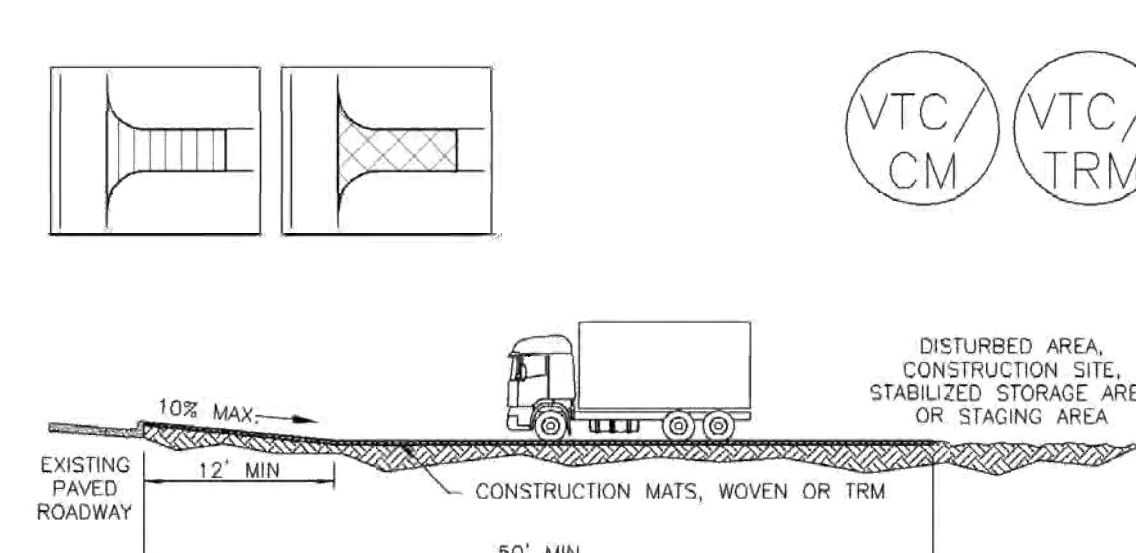

**VTC-3. VEHICLE TRACKING CONTROL W/ CONSTRUCTION MAT OR TURF REINFORCEMENT MAT (TRM)**

November 2010 Urban Drainage and Flood Control District VTC-5  
Urban Storm Drainage Criteria Manual Volume 3

**Rock Sock (RS) SC-5**

**ROCK SOCK MAINTENANCE NOTES**

- INSPECT BMPs EACH WORKDAY, AND MAINTAIN THEM IN EFFECTIVE OPERATING CONDITION. MAINTENANCE OF BMPs SHOULD BE PROACTIVE, NOT REACTIVE. INSPECT BMPs AS SOON AS POSSIBLE (AND ALWAYS WITHIN 24 HOURS) FOLLOWING A STORM THAT CAUSES SURFACE EROSION, AND PERFORM NECESSARY MAINTENANCE.
- FREQUENT OBSERVATIONS AND MAINTENANCE ARE NECESSARY TO MAINTAIN BMPs IN EFFECTIVE OPERATING CONDITION. INSPECTIONS AND CORRECTIVE MEASURES SHOULD BE DOCUMENTED THOROUGHLY.
- WHERE BMPs HAVE FAILED, REPAIR OR REPLACEMENT SHOULD BE INITIATED UPON DISCOVERY OF THE FAILURE.
- ROCK SOCKS SHALL BE REPLACED IF THEY BECOME HEAVILY SOILED, OR DAMAGED BEYOND REPAIR.
- SEDIMENT ACCUMULATED UPSTREAM OF ROCK SOCKS SHALL BE REMOVED AS NEEDED TO MAINTAIN FUNCTIONALITY OF THE BMP. TYPICALLY WHEN DEPTH OF ACCUMULATED SEDIMENTS IS APPROXIMATELY 1/2 OF THE HEIGHT OF THE ROCK SOCK.
- ROCK SOCKS ARE TO REMAIN IN PLACE UNTIL THE UPSTREAM DISTURBED AREA IS STABILIZED AND APPROVED BY THE LOCAL JURISDICTION.
- WHEN ROCK SOCKS ARE REMOVED, ALL DISTURBED AREAS SHALL BE COVERED WITH TOPSOIL, SEEDED AND MULCHED OR OTHERWISE STABILIZED AS APPROVED BY LOCAL JURISDICTION.

(DETAIL ADAPTED FROM TOWN OF PARKER, COLORADO AND CITY OF AURORA, COLORADO, NOT AVAILABLE IN AUTOCAD)  
NOTE: MANY JURISDICTIONS HAVE BMP DETAILS THAT VARY FROM UDFCD STANDARD DETAILS. CONSULT WITH LOCAL JURISDICTIONS AS TO WHICH DETAIL SHOULD BE USED WHEN DIFFERENCES ARE NOTED.

NOTE: THE DETAILS INCLUDED WITH THIS FACT SHEET SHOW COMMONLY USED, CONVENTIONAL METHODS OF ROCK SOCK INSTALLATION IN THE DENVER METROPOLITAN AREA. THERE ARE MANY OTHER SIMILAR PROPRIETARY PRODUCTS ON THE MARKET. UDFCD NEITHER ENDORSES NOR DISCOURAGES USE OF PROPRIETARY PROTECTION PRODUCTS. HOWEVER, IN THE EVENT PROPRIETARY METHODS ARE USED, THE APPROPRIATE DETAIL FROM THE MANUFACTURER MUST BE INCLUDED IN THE SWMP AND THE BMP MUST BE INSTALLED AND MAINTAINED AS SHOWN IN THE MANUFACTURER'S DETAILS.

November 2010 Urban Drainage and Flood Control District RS-3  
Urban Storm Drainage Criteria Manual Volume 3

**SM-4 Vehicle Tracking Control (VTC)**

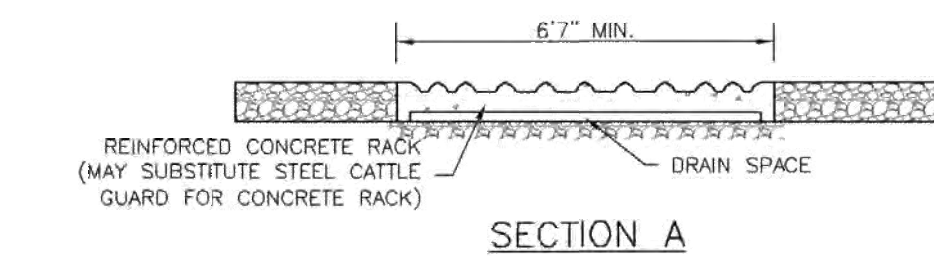
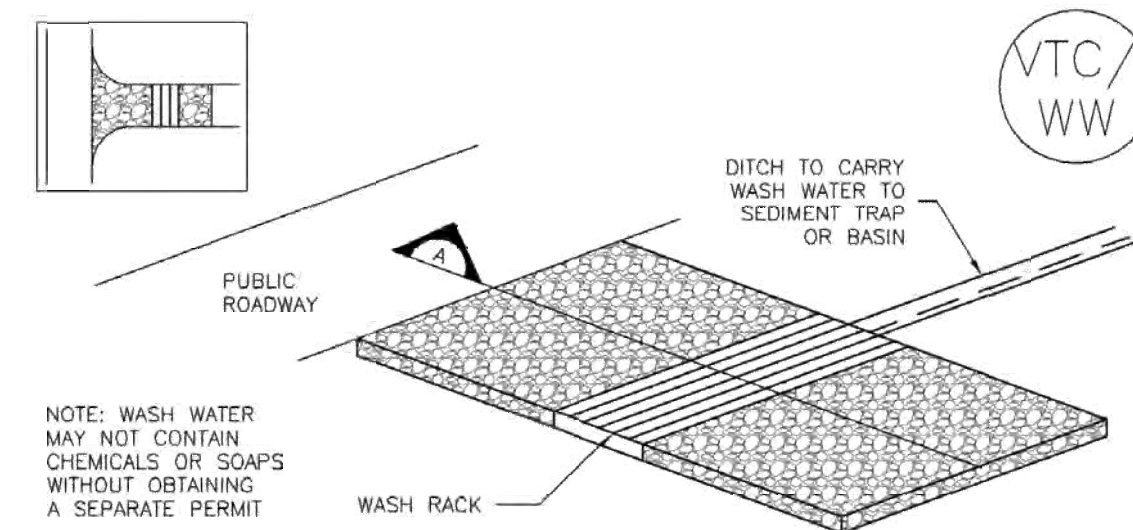

**VTC-2. AGGREGATE VEHICLE TRACKING CONTROL WITH WASH RACK**

VTC-4 Urban Drainage and Flood Control District November 2010  
Urban Storm Drainage Criteria Manual Volume 3

**SM-4 Vehicle Tracking Control (VTC)**

**STABILIZED CONSTRUCTION ENTRANCE/EXIT INSTALLATION NOTES**

- SEE PLAN VIEW FOR -LOCATION OF CONSTRUCTION ENTRANCE(S)/EXIT(S). -TYPE OF CONSTRUCTION ENTRANCE(S)/EXIT(S) (WITH/WITHOUT WHEEL WASH, CONSTRUCTION MAT OR TRM).
- CONSTRUCTION MAT OR TRM STABILIZED CONSTRUCTION ENTRANCES ARE ONLY TO BE USED ON SHORT DURATION PROJECTS (TYPICALLY RANGING FROM A WEEK TO A MONTH) WHERE THERE WILL BE LIMITED VEHICULAR ACCESS.
- A STABILIZED CONSTRUCTION ENTRANCE/EXIT SHALL BE LOCATED AT ALL ACCESS POINTS WHERE VEHICLES ACCESS THE CONSTRUCTION SITE FROM PAVED RIGHT-OF-WAYS.
- STABILIZED CONSTRUCTION ENTRANCE/EXIT SHALL BE INSTALLED PRIOR TO ANY LAND DISTURBING ACTIVITIES.
- A NON-WOVEN GEOTEXTILE FABRIC SHALL BE PLACED UNDER THE STABILIZED CONSTRUCTION ENTRANCE/EXIT PRIOR TO THE PLACEMENT OF ROCK.
- UNLESS OTHERWISE SPECIFIED BY LOCAL JURISDICTION, ROCK SHALL CONSIST OF DOT SECT. #703, AASHTO #3 COARSE AGGREGATE OR 6" (MINUS) ROCK.

**STABILIZED CONSTRUCTION ENTRANCE/EXIT MAINTENANCE NOTES**

- INSPECT BMPs EACH WORKDAY, AND MAINTAIN THEM IN EFFECTIVE OPERATING CONDITION. MAINTENANCE OF BMPs SHOULD BE PROACTIVE, NOT REACTIVE. INSPECT BMPs AS SOON AS POSSIBLE (AND ALWAYS WITHIN 24 HOURS) FOLLOWING A STORM THAT CAUSES SURFACE EROSION, AND PERFORM NECESSARY MAINTENANCE.
- FREQUENT OBSERVATIONS AND MAINTENANCE ARE NECESSARY TO MAINTAIN BMPs IN EFFECTIVE OPERATING CONDITION. INSPECTIONS AND CORRECTIVE MEASURES SHOULD BE DOCUMENTED THOROUGHLY.
- WHERE BMPs HAVE FAILED, REPAIR OR REPLACEMENT SHOULD BE INITIATED UPON DISCOVERY OF THE FAILURE.
- ROCK SHALL BE REPLACED OR REGRADED AS NECESSARY TO THE STABILIZED ENTRANCE/EXIT TO MAINTAIN A CONSISTENT DEPTH.
- SEDIMENT TRACKED ONTO PAVED ROADS IS TO BE REMOVED THROUGHOUT THE DAY AND AT THE END OF THE DAY BY SHOVELING OR SWEEPING. SEDIMENT MAY NOT BE WASHED DOWN STORM SEWER DRAINS.

(DETAILS ADAPTED FROM CITY OF BROOMFIELD, COLORADO, NOT AVAILABLE IN AUTOCAD)

VTC-6 Urban Drainage and Flood Control District November 2010  
Urban Storm Drainage Criteria Manual Volume 3

UNTIL SUCH TIME AS THESE DRAWINGS ARE APPROVED BY THE APPROPRIATE REVIEWING AGENCIES, OR ENGINEERING APPROVES THEIR USE, THESE DRAWINGS ARE DESIGNATED BY WRITTEN AUTHORIZATION.

PREPARED FOR  
**BRIAN WARD**  
CITY OF GREELEY-PUBLIC WORKS  
1001 9TH AVENUE  
GREELEY, CO 80631  
(970) 350-9792

**J.R. ENGINEERING**  
A Westlan Company  
Central 303-740-9888 • Colorado Springs 719-588-2593  
Fort Collins 970-491-9888 • www.jrengineering.com

BY	DATE	REVISION	No.	N/A	N/A	N/A	N/A	N/A	N/A	N/A

CENTERPLACE TURN LANE IMPROVEMENTS  
DETAIL SHEETS

SHEET 13 OF 14

JOB NO. 39722.02



Know what's below.  
Call before you dig.



SC-6 Inlet Protection (IP)

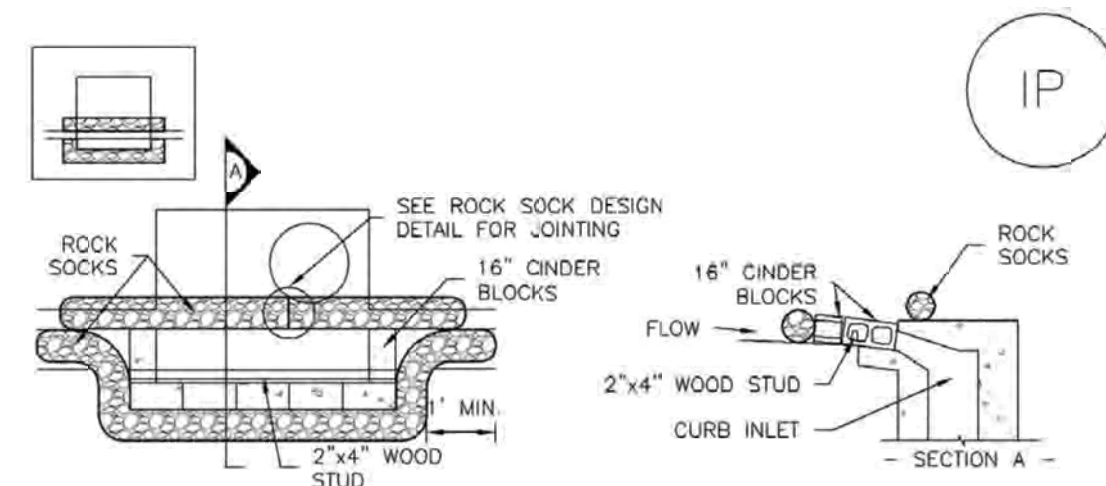

IP-1. BLOCK AND ROCK SOCK SUMP OR ON GRADE INLET PROTECTION

BLOCK AND CURB SOCK INLET PROTECTION INSTALLATION NOTES

1. SEE ROCK SOCK DESIGN DETAIL FOR INSTALLATION REQUIREMENTS.
2. CONCRETE "CINDER" BLOCKS SHALL BE LAID ON THEIR SIDES AROUND THE INLET IN A SINGLE ROW, ABUTTING ONE ANOTHER WITH THE OPEN END FACING AWAY FROM THE CURB.
3. GRAVEL BAGS SHALL BE PLACED AROUND CONCRETE BLOCKS, CLOSELY ABUTTING ONE ANOTHER AND JOINTED TOGETHER IN ACCORDANCE WITH ROCK SOCK DESIGN DETAIL.

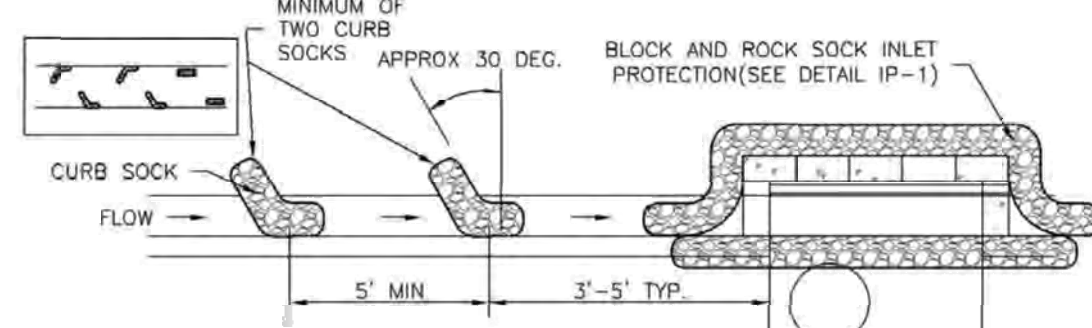

IP-2. CURB ROCK SOCKS UPSTREAM OF INLET PROTECTION

CURB ROCK SOCK INLET PROTECTION INSTALLATION NOTES

1. SEE ROCK SOCK DESIGN DETAIL INSTALLATION REQUIREMENTS.
2. PLACEMENT OF THE SOCK SHALL BE APPROXIMATELY 30 DEGREES FROM PERPENDICULAR IN THE OPPOSITE DIRECTION OF FLOW.
3. SOCKS ARE TO BE FLUSH WITH THE CURB AND SPACED A MINIMUM OF 5 FEET APART.
4. AT LEAST TWO CURB SOCKS IN SERIES ARE REQUIRED UPSTREAM OF ON-GRADE INLETS.

Inlet Protection (IP) SC-6

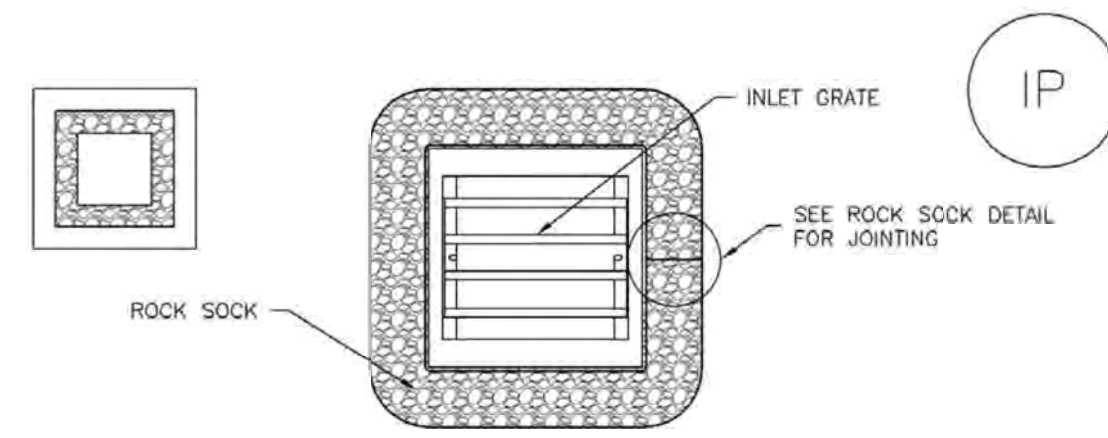

IP-3. ROCK SOCK SUMP/AREA INLET PROTECTION

ROCK SOCK SUMP/AREA INLET PROTECTION INSTALLATION NOTES

1. SEE ROCK SOCK DESIGN DETAIL FOR INSTALLATION REQUIREMENTS.
2. STRAW WATTLES/SEDIMENT CONTROL LOGS MAY BE USED IN PLACE OF ROCK SOCKS FOR INLETS IN PEROUS AREAS. INSTALL PER SEDIMENT CONTROL LOG DETAIL.

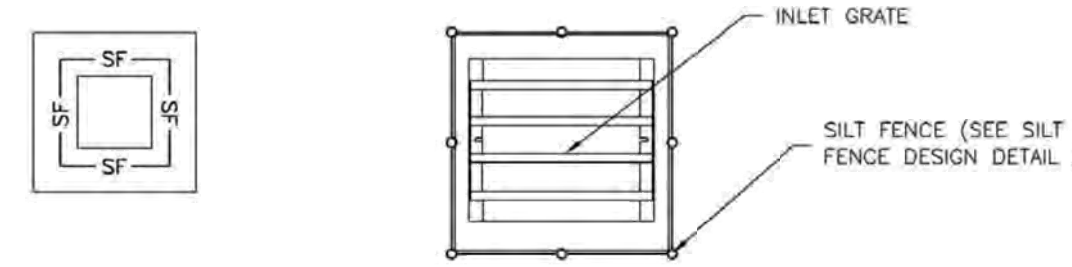

IP-4. SILT FENCE FOR SUMP INLET PROTECTION

SILT FENCE INLET PROTECTION INSTALLATION NOTES

1. SEE SILT FENCE DESIGN DETAIL FOR INSTALLATION REQUIREMENTS.
2. POSTS SHALL BE PLACED AT EACH CORNER OF THE INLET AND AROUND THE EDGES AT A MAXIMUM SPACING OF 3 FEET.
3. STRAW WATTLES/SEDIMENT CONTROL LOGS MAY BE USED IN PLACE OF SILT FENCE FOR INLETS IN PEROUS AREAS. INSTALL PER SEDIMENT CONTROL LOG DETAIL.

SC-6 Inlet Protection (IP)

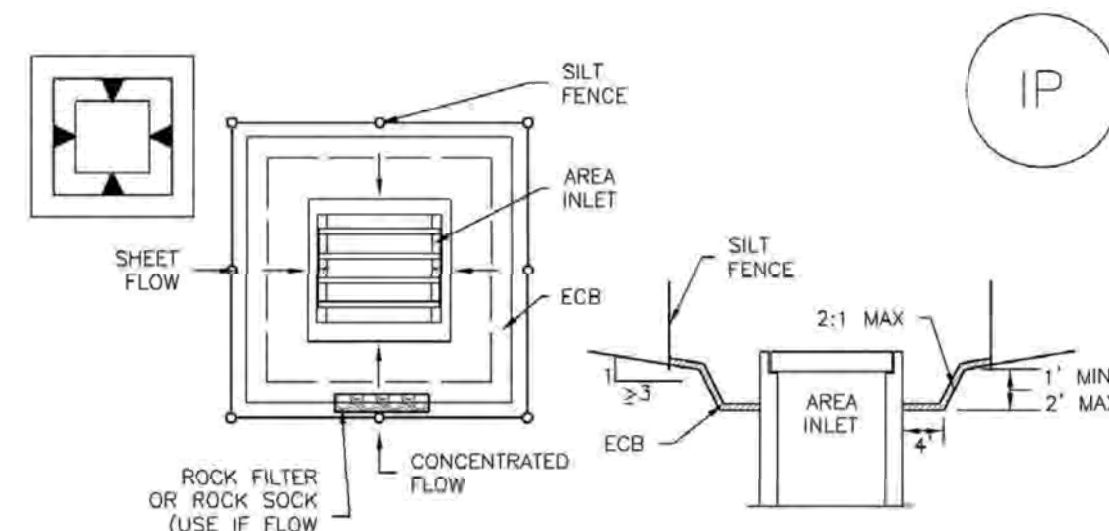

IP-5. OVEREXCAVATION INLET PROTECTION

OVEREXCAVATION INLET PROTECTION INSTALLATION NOTES

1. THIS FORM OF INLET PROTECTION IS PRIMARILY APPLICABLE FOR SITES THAT HAVE NOT YET REACHED FINAL GRADE AND SHOULD BE USED ONLY FOR INLETS WITH A RELATIVELY SMALL CONTRIBUTING DRAINAGE AREA.
2. WHEN USING FOR CONCENTRATED FLOWS, SHAPE BASIN IN 2:1 RATIO WITH LENGTH ORIENTED TOWARDS DIRECTION OF FLOW.
3. SEDIMENT MUST BE PERIODICALLY REMOVED FROM THE OVEREXCAVATED AREA.

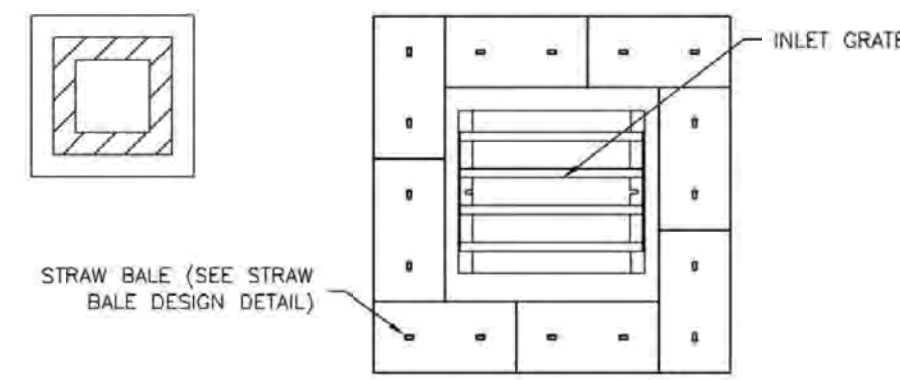

IP-6. STRAW BALE FOR SUMP INLET PROTECTION

STRAW BALE BARRIER INLET PROTECTION INSTALLATION NOTES

1. SEE STRAW BALE DESIGN DETAIL FOR INSTALLATION REQUIREMENTS.
2. BALES SHALL BE PLACED IN A SINGLE ROW AROUND THE INLET WITH ENDS OF BALES TIGHTLY ABUTTING ONE ANOTHER.

Construction Fence (CF) SM-3

CONSTRUCTION FENCE MAINTENANCE NOTES

1. INSPECT BMPs EACH WORKDAY, AND MAINTAIN THEM IN EFFECTIVE OPERATING CONDITION. MAINTENANCE OF BMPs SHOULD BE PROACTIVE, NOT REACTIVE. INSPECT BMPs AS SOON AS POSSIBLE (AND ALWAYS WITHIN 24 HOURS) FOLLOWING A STORM THAT CAUSES SURFACE EROSION, AND PERFORM NECESSARY MAINTENANCE.
2. FREQUENT OBSERVATIONS AND MAINTENANCE ARE NECESSARY TO MAINTAIN BMPs IN EFFECTIVE OPERATING CONDITION. INSPECTIONS AND CORRECTIVE MEASURES SHOULD BE DOCUMENTED THOROUGHLY.
3. WHERE BMPs HAVE FAILED, REPAIR OR REPLACEMENT SHOULD BE INITIATED UPON DISCOVERY OF THE FAILURE.
4. CONSTRUCTION FENCE SHALL BE REPAIRED OR REPLACED WHEN THERE ARE SIGNS OF DAMAGE SUCH AS RIPS OR SACS. CONSTRUCTION FENCE IS TO REMAIN IN PLACE UNTIL THE UPSTREAM DISTURBED AREA IS STABILIZED AND APPROVED BY THE LOCAL JURISDICTION.
5. WHEN CONSTRUCTION FENCES ARE REMOVED, ALL DISTURBED AREAS ASSOCIATED WITH THE INSTALLATION, MAINTENANCE, AND/OR REMOVAL OF THE FENCE SHALL BE COVERED WITH TOPSOIL, SEEDED AND MULCHED, OR OTHERWISE STABILIZED AS APPROVED BY LOCAL JURISDICTION.

NOTE: MANY JURISDICTIONS HAVE BMP DETAILS THAT VARY FROM UDFCD STANDARD DETAILS. CONSULT WITH LOCAL JURISDICTIONS AS TO WHICH DETAIL SHOULD BE USED WHEN DIFFERENCES ARE NOTED.

(DETAIL ADAPTED FROM TOWN OF PARKER, COLORADO, NOT AVAILABLE IN AUTOCAD)

UNTIL SUCH TIME AS THESE DRAWINGS ARE APPROVED BY THE APPROPRIATE REVIEWING AGENCIES, OR ENGINEERING APPROVES THEIR USE, THESE DRAWINGS ARE DESIGNATED BY WRITTEN AUTHORIZATION.

PREPARED FOR  
**BRIAN WARD**  
CITY OF GREELEY—PUBLIC WORKS  
1001 9TH AVENUE  
GREELEY, CO 80631  
(970) 350-9792

**J.R. ENGINEERING**  
A Westbran Company  
Central 303-740-9888 • Colorado Springs 719-588-2593  
Fort Collins 970-491-9888 • www.jrengineering.com

Inlet Protection (IP) SC-6

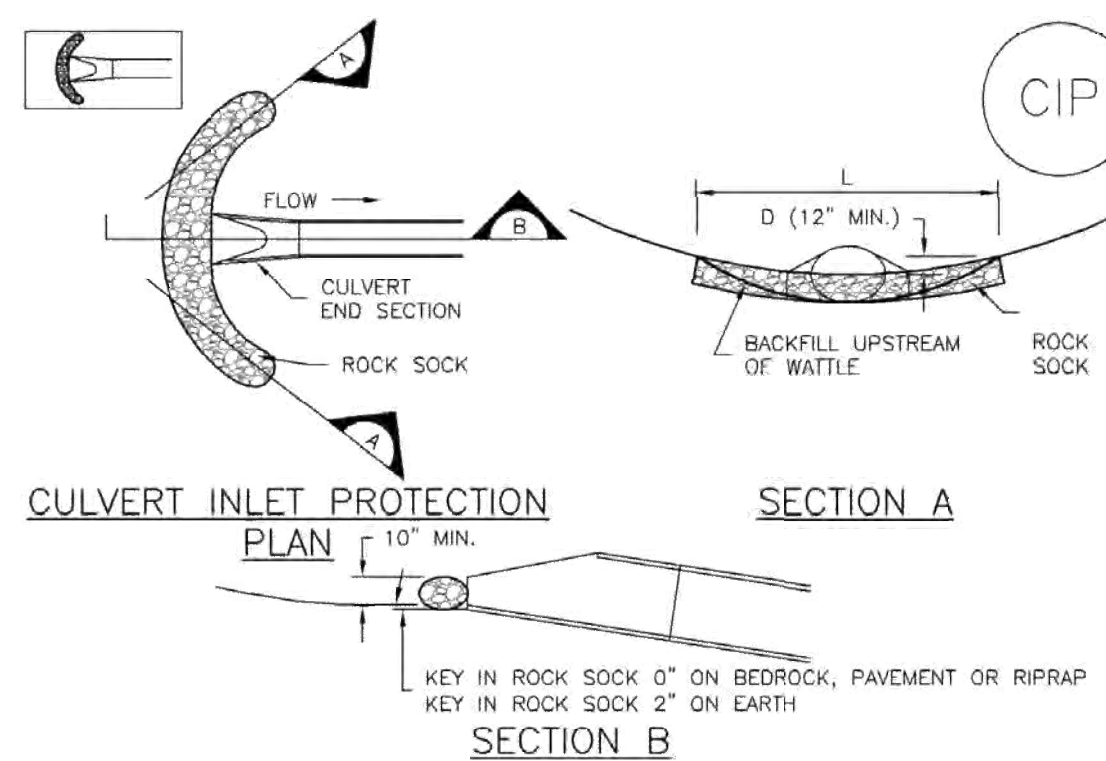

CIP-1. CULVERT INLET PROTECTION

CULVERT INLET PROTECTION INSTALLATION NOTES

1. SEE PLAN VIEW FOR -LOCATION OF CULVERT INLET PROTECTION.
2. SEE ROCK SOCK DESIGN DETAIL FOR ROCK GRADATION REQUIREMENTS AND JOINTING DETAIL.

CULVERT INLET PROTECTION MAINTENANCE NOTES

1. INSPECT BMPs EACH WORKDAY, AND MAINTAIN THEM IN EFFECTIVE OPERATING CONDITION. MAINTENANCE OF BMPs SHOULD BE PROACTIVE, NOT REACTIVE. INSPECT BMPs AS SOON AS POSSIBLE (AND ALWAYS WITHIN 24 HOURS) FOLLOWING A STORM THAT CAUSES SURFACE EROSION, AND PERFORM NECESSARY MAINTENANCE.
2. FREQUENT OBSERVATIONS AND MAINTENANCE ARE NECESSARY TO MAINTAIN BMPs IN EFFECTIVE OPERATING CONDITION. INSPECTIONS AND CORRECTIVE MEASURES SHOULD BE DOCUMENTED THOROUGHLY.
3. WHERE BMPs HAVE FAILED, REPAIR OR REPLACEMENT SHOULD BE INITIATED UPON DISCOVERY OF THE FAILURE.
4. SEDIMENT ACCUMULATED UPSTREAM OF THE CULVERT SHALL BE REMOVED WHEN THE SEDIMENT DEPTH IS 1/2 THE HEIGHT OF THE ROCK SOCK.
5. CULVERT INLET PROTECTION SHALL REMAIN IN PLACE UNTIL THE UPSTREAM DISTURBED AREA IS PERMANENTLY STABILIZED AND APPROVED BY THE LOCAL JURISDICTION.

(DETAILS ADAPTED FROM AURORA, COLORADO, NOT AVAILABLE IN AUTOCAD)

NOTE: MANY JURISDICTIONS HAVE BMP DETAILS THAT VARY FROM UDFCD STANDARD DETAILS. CONSULT WITH LOCAL JURISDICTIONS AS TO WHICH DETAIL SHOULD BE USED WHEN DIFFERENCES ARE NOTED.

SC-6 Inlet Protection (IP)

GENERAL INLET PROTECTION INSTALLATION NOTES

1. SEE PLAN VIEW FOR:  
-LOCATION OF INLET PROTECTION.  
-TYPE OF INLET PROTECTION (IP.1, IP.2, IP.3, IP.4, IP.5, IP.6)
2. INLET PROTECTION SHALL BE INSTALLED PROMPTLY AFTER INLET CONSTRUCTION OR PAVING IS COMPLETE (TYPICALLY WITHIN 48 HOURS), IF A RAINFALL/RUNOFF EVENT IS FORECAST, INSTALL INLET PROTECTION PRIOR TO ONSET OF EVENT.
3. MANY JURISDICTIONS HAVE BMP DETAILS THAT VARY FROM UDFCD STANDARD DETAILS. CONSULT WITH LOCAL JURISDICTIONS AS TO WHICH DETAIL SHOULD BE USED WHEN DIFFERENCES ARE NOTED.

INLET PROTECTION MAINTENANCE NOTES

1. INSPECT BMPs EACH WORKDAY, AND MAINTAIN THEM IN EFFECTIVE OPERATING CONDITION. MAINTENANCE OF BMPs SHOULD BE PROACTIVE, NOT REACTIVE. INSPECT BMPs AS SOON AS POSSIBLE (AND ALWAYS WITHIN 24 HOURS) FOLLOWING A STORM THAT CAUSES SURFACE EROSION, AND PERFORM NECESSARY MAINTENANCE.
2. FREQUENT OBSERVATIONS AND MAINTENANCE ARE NECESSARY TO MAINTAIN BMPs IN EFFECTIVE OPERATING CONDITION. INSPECTIONS AND CORRECTIVE MEASURES SHOULD BE DOCUMENTED THOROUGHLY.
3. WHERE BMPs HAVE FAILED, REPAIR OR REPLACEMENT SHOULD BE INITIATED UPON DISCOVERY OF THE FAILURE.
4. SEDIMENT ACCUMULATED UPSTREAM OF INLET PROTECTION SHALL BE REMOVED AS NECESSARY TO MAINTAIN BMP EFFECTIVENESS, TYPICALLY WHEN STORAGE VOLUME REACHES 50% OF CAPACITY, A DEPTH OF 6" WHEN SILT FENCE IS USED, OR 1/4 OF THE HEIGHT FOR STRAW BALES.
5. INLET PROTECTION IS TO REMAIN IN PLACE UNTIL THE UPSTREAM DISTURBED AREA IS PERMANENTLY STABILIZED, UNLESS THE LOCAL JURISDICTION APPROVES EARLIER REMOVAL OF INLET PROTECTION IN STREETS.
6. WHEN INLET PROTECTION AT AREA INLETS IS REMOVED, THE DISTURBED AREA SHALL BE COVERED WITH TOP SOIL, SEEDED AND MULCHED, OR OTHERWISE STABILIZED IN A MANNER APPROVED BY THE LOCAL JURISDICTION.

(DETAIL ADAPTED FROM TOWN OF PARKER, COLORADO AND CITY OF AURORA, COLORADO, NOT AVAILABLE IN AUTOCAD)

NOTE: MANY JURISDICTIONS HAVE BMP DETAILS THAT VARY FROM UDFCD STANDARD DETAILS. CONSULT WITH LOCAL JURISDICTIONS AS TO WHICH DETAIL SHOULD BE USED WHEN DIFFERENCES ARE NOTED.

NOTE: THE DETAILS INCLUDED WITH THIS FACT SHEET SHOW COMMONLY USED, CONVENTIONAL METHODS OF INLET PROTECTION IN THE DENVER METROPOLITAN AREA. THERE ARE MANY PROPRIETARY INLET PROTECTION METHODS ON THE MARKET. UDFCD NEITHER ENDORSES NOR DISCOURAGES USE OF PROPRIETARY INLET PROTECTION; HOWEVER, IN THE EVENT PROPRIETARY METHODS ARE USED, THE APPROPRIATE DETAIL FROM THE MANUFACTURER MUST BE INCLUDED IN THE SWMP AND THE BMP MUST BE INSTALLED AND MAINTAINED AS SHOWN IN THE MANUFACTURER'S DETAILS.

NOTE: SOME MUNICIPALITIES DISCOURAGE OR PROHIBIT THE USE OF STRAW BALES FOR INLET PROTECTION. CHECK WITH LOCAL JURISDICTION TO DETERMINE IF STRAW BALE INLET PROTECTION IS ACCEPTABLE.

SM-3 Construction Fence (CF)

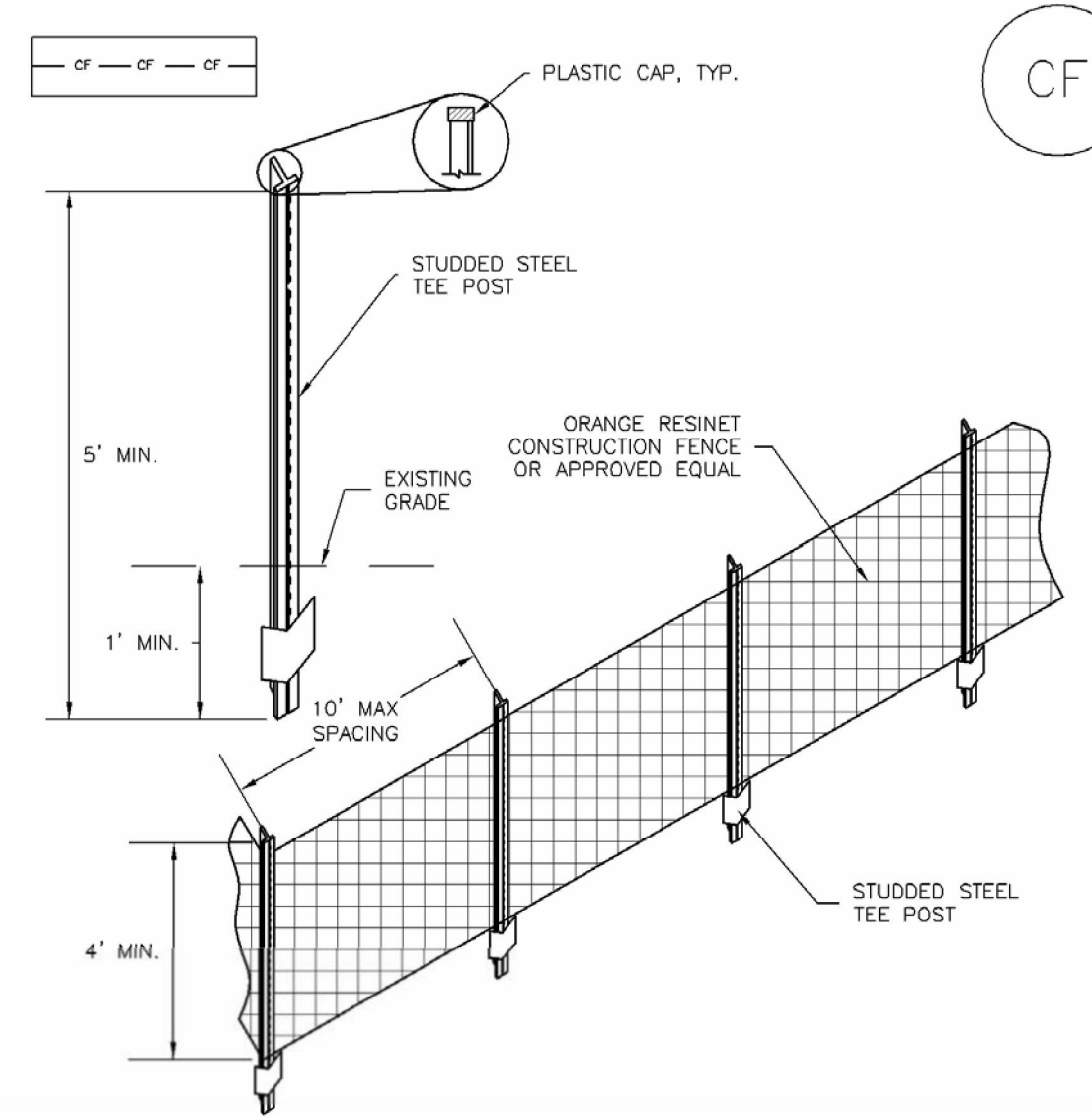

CF-1. PLASTIC MESH CONSTRUCTION FENCE

CONSTRUCTION FENCE INSTALLATION NOTES

1. SEE PLAN VIEW FOR:  
-LOCATION OF CONSTRUCTION FENCE.
2. CONSTRUCTION FENCE SHOWN SHALL BE INSTALLED PRIOR TO ANY LAND DISTURBING ACTIVITIES.
3. CONSTRUCTION FENCE SHALL BE COMPOSED OF ORANGE, CONTRACTOR-GRADE MATERIAL THAT IS AT LEAST 4' HIGH. METAL POSTS SHOULD HAVE A PLASTIC CAP FOR SAFETY.
4. STUDDED STEEL TEE POSTS SHALL BE UTILIZED TO SUPPORT THE CONSTRUCTION FENCE. MAXIMUM SPACING FOR STEEL TEE POSTS SHALL BE 10'.
5. CONSTRUCTION FENCE SHALL BE SECURELY FASTENED TO THE TOP, MIDDLE, AND BOTTOM OF EACH POST.

BY	DATE	No.	REVISION	H-SCALE	V-SCALE	DATE	DESIGNED BY	DRAWN BY	CHECKED BY	MJP
CENTERPLACE TURN LANE IMPROVEMENTS DETAIL SHEETS										
SHEET 14 OF 14										
JOB NO. 39722.02										



**SPECIAL PROVISIONS FOR CITY OF GREELEY**

**Centerplace Turn Lane Improvements**

**Addendum 2**

**Bid Items 3310 – CONCRETE**

The contractor shall pour a thickened edge at construction joints and use dowels to connect concrete pours.

Bid Item 3310 Concrete Curb Ramp shall include the cost for the construction of the ADA detectable warnings. The ADA detectable warning device shall consist of cast iron truncated domes. Brick and stamped concrete are not allowed. Prior to installation of the plates, concrete shall be installed and consolidated as a base for the plates. The concrete shall be placed to a thickness that will allow for the base surface of the plates to be at the same elevation as the adjacent concrete. The plates shall be embedded into the plastic concrete in accordance with the manufacturer's specifications.

Bid Item 3310 Concrete Sidewalk (6 Inch) shall include the cost for the construction of the depressed pedestrian path sidewalk.

Bid Items 3310 Vertical Curb and Gutter (Median, Spill, Catch) shall include the cost for the construction of the depressed pedestrian path 6" curb.

Bid Item 3310 Median Cover (Patterned Concrete)-shall conform to Section 00620 Specifications Colored and Patterned Concrete for Median Paving.