

**SECTION 6.0 – STORM DRAINS
TABLE OF CONTENTS**

SECTION 6.0 STORM DRAINS	3
6.1 INTRODUCTION	3
6.2 CONSTRUCTION MATERIALS/INSTALLATION OF STORM DRAINS	3
6.2.1 CONSTRUCTION MATERIALS.....	3
6.2.1.A STORM DRAIN PIPING MATERIALS	3
TABLE 6.2.1.A - STORM DRAIN STANDARDS.....	3
6.2.1.B BEDDING MATERIALS	4
6.2.1.C CONCRETE MATERIALS	5
6.2.2 INSTALLATION OF STORM DRAINS.....	5
6.2.2.A EXCAVATION.....	5
6.2.2.B PIPE INSTALLATION AND TESTING	5
6.2.2.C Backfill and Compaction	8
6.2.2.D Inspection and Testing.....	8
6.2.3 CONNECTIONS TO EXISTING STORM DRAIN	9
6.2.4 PIPE INSPECTION CHECKLIST.....	10
6.2.5 PIPE INSTALLATION CHECKLIST	11
6.2.6 SUB-SURFACE UTILITY ENGINEERING.....	12
6.2.7 DRAWINGS OF RECORD (AS-BUILTS).....	12
6.3 HYDRAULIC DESIGN	12
6.3.1 PIPE FRICTION LOSSES	12
6.3.2 PIPE FORM LOSSES.....	12
6.3.2.A EXPANSION LOSSES	13
6.3.2.B CONTRACTION LOSSES	13
6.3.2.C BEND LOSSES	13
6.3.2.D JUNCTION AND MANHOLE LOSSES.....	14
6.3.3 STORMWATER OUTLETS	14
6.3.4 PARTIALLY FULL PIPE FLOW	14
6.3.5 HYDRAULIC RESEARCH	14
6.4 VERTICAL ALIGNMENT.....	15
6.5 HORIZONTAL ALIGNMENT	15
6.6 PIPE SIZE.....	16
6.7 MANHOLES	16
6.7.1 GENERAL INFORMATION.....	16
Table 6.7.1 – Manhole Size	16
6.7.2 MANHOLE MATERIALS.....	16
6.7.2.A MANHOLE	16
6.7.2.B STEPS.....	17
6.7.2.C RINGS AND COVERS.....	17
6.7.2.D MANHOLE GASKETS	17
6.7.3 MANHOLE CONSTRUCTION	18
6.7.3.A MATERIALS	18
6.7.3.B SURFACE PREPARATION, EXCAVATION, DEWATERING	18
6.7.3.C MANHOLE BASE	18
6.7.3.D MANHOLE BARRELS	18
6.7.3.E TOP OR CONE SECTIONS	19
6.7.3.F WATERTIGHTNESS	19
6.7.3.G CONNECTIONS	20

6.7.3.H	BEDDING AND BACKFILLING	20
6.7.3.i	QUALITY CONTROL	20
6.7.3.j	CLEAN UP	20
6.8	STORMCEPTOR – OIL/SEDIMENT IN-LINE SEPARATOR UNIT	20
6.9	MAINTENANCE AND ACCESS EASEMENTS.....	21
Table 6.9 –	Required Storm Drain Maintenance and Access Easements.....	21
6.10	DESIGN EXAMPLE.....	21
6.11	CHECKLIST	24

SECTION 6.0 STORM DRAINS

6.1 INTRODUCTION

Storm drains are required when other parts of the drainage system, primarily curb, gutter, and roadside ditches no longer have capacity for the additional stormwater runoff.

Except as modified herein, the design of storm drains shall be in accordance with the USDCM, Volume 1, Chapter, "Street/Inlets/Storm Sewers". Reference is made to follow specific sections in the USDCM for clarity. The user is referred to the USDCM and any other references cited for additional information and basic design concepts.

6.2 CONSTRUCTION MATERIALS/INSTALLATION OF STORM DRAINS

6.2.1 CONSTRUCTION MATERIALS

6.2.1.A STORM DRAIN PIPING MATERIALS

All storm drains within the City shall be constructed using one of the following materials and meet applicable standards as presented below:

TABLE 6.2.1.A - STORM DRAIN STANDARDS	
Pipe Material	Standard
Reinforced Concrete Pipe (RCP)	ASTM C-33, 76, 150, 260, 361, 443, 494 (Type A or D), 497, & 655, ASTM E 329 and AASHTO M 170, and 242 and FED Specifications (FS): SS-S-00210
Plastic Pipe (PVC)	AASHTO M304M-911, ASTM D-1784, 2122, 2321, 2412, & 3212, and ASTM D3034 DR35 or better, and with elastomeric gaskets per ASTM F477, and ASTM F679, 794, 949, & 1803
Aluminized Steel Pipe (ASP)	AASHTO M-36, 198 & 274 and ASTM A-760, 796, 798 & 891
Corrugated Steel for Culverts Only	AASHTO M-36, 167, 190, 218, 243, 245, 246, 264, 289 and ASTM A-444, 742, 760, 761, 762, 806, 819, 849, 885 and D-1056
High Density Polyethylene Pipe (HDPE)	AASHTO M-252, 294 (Type S), and Section 18 with rubber water-tight joints and ASTM D-1056 (Grade 2A2), 1248, 2321, 3212 & 3350 (cell class 324420C or higher) and F477 & 667

Notes:

Elliptical and arched pipe should be used only when conditions prevent the use of circular pipe

At the option of the Contractor, and with the City's written approval, non-reinforced concrete pipe conforming to ASTM-C14 and AASHTO M 86 may be used in lieu of reinforced concrete pipe for all sizes 36 inches in diameter and smaller. It shall meet the same D-load to produce the ultimate load under the three-edge bearing method as specified for reinforced concrete pipe in accordance with AASHTO M170, and the Contractor provides

written certification that it does so. Wall thickness of pipe may be increased as required to meet D-load requirement.

All requirements for reinforced concrete pipe, except those referring to reinforcement shall apply to non-reinforced concrete pipe.

The minimum class for RCP pipe shall be Class-III with flexible gasket material (water tight rubber gaskets) meeting ASTM C443 and gasket bell and spigot joints. The required pipe strength shall be determined from the actual depth of cover, true load, and proposed field conditions. A typical design strength calculation shall be submitted to the City for approval.

ASP and HDPE pipe may be used for storm drain in parks, green belts, and other open space areas only upon approval of the City. Where corrugated metal pipe (CMP) is intended to be used as culvert material, the minimum gauge for the pipe shall be determined from Colorado Department of Transportation (CDOT) Standard Plan M-603-1, latest edition, for actual depth of cover. Site-specific calculations may be submitted utilizing the following structural design specifications: AASHTO – M167M / M167-04; ASTM - Standard Practice for Structural Design of Corrugated Steel Pipe, Pipe Arches, and Arches for Storm and Sanitary Sewers and Other Buried Applications, ASTM A796. The following, ASP, HDPE or CMP pipe shall not be used under railroad tracks within the City. PVC may be used provided a schedule 80 steel pipe acts as a sleeve as required by the American Railroad Engineers Association Specifications, AREA.

Also, when CMP is intended to be used as culvert material, site soil pH and Rmin, minimum resistivity, tests shall be performed. pH shall be measured for soil and water. Minimum resistivity shall be for soil and water and shall be determined in the laboratory and not in the field. Corrugated aluminum pipe may be used when the pH is between 7.2 and 9.0 and Rmin is 1,000 ohm-cm or greater. Galvanized steel corrugated pipe shall be used when the pH is between 6.0 and 10.0 and Rmin is 2000 ohm-cm or greater. Supplemental corrosion protection coatings approved by the City shall be applied to corrugated steel pipe when the pH is outside the above-stated range and/or Rmin is less than 2000 ohm-cm.

When ASP pipe is intended to be used as the storm drain pipe material, site soil pH and Rmin, minimum resistivity, tests shall be performed. PH shall be measured for soil and water. Minimum resistivity shall be for soil and water and shall be determined in the laboratory and not in the field. ASP pipe may be used when the pH is between 7.2 and 9.0 and Rmin is 1,000 ohm-cm or greater.

6.2.1.B BEDDING MATERIALS

RCP pipe and other rigid pipe systems are susceptible to failure due to improper bedding and backfill procedures. Bedding for RCP pipe shall be 3/8-inch squeegee, per the following gradation:

SIZE	PERCENT PASSING
3/8"	80-100
#4	0-80
#200	0-4

Backfill of ASP, HDPE, CMP or PVC pipe or any flexible pipe is very critical. Non-structural (flexible) pipe materials shall include bedding requirements as specified in USDCM latest edition. Backfill is a major component to the structural integrity of the pipe system. Bedding materials and compaction must have good quality control for a successful pipe installation.

See Standard Stormwater Bedding Details 6-6 and 6-7 for all types of pipe.

6.2.1.C CONCRETE MATERIALS

Concrete materials for manholes, junction boxes, vaults, headwalls, cutoff walls, and other miscellaneous concrete structures within the storm drain system shall conform to or exceed Metropolitan Government Engineer's Council (MGPEC) specifications Item 11, Portland Cement Concrete Pavement; Section 11.2, Materials.

Rebar shall conform to the latest edition of American Concrete Institute 318-89 (ACI 318-89) or 602-Reinforcing Steel CDOT Standard Specifications for Road and Bridge Construction.

6.2.2 INSTALLATION OF STORM DRAINS

6.2.2.A EXCAVATION

(See Volume 1, Street Design Standards and Construction Specifications, Section 02595, Street Cut and Excavation Repair).

6.2.2.B PIPE INSTALLATION AND TESTING

All pipe shall be installed in accordance with the manufacturer's recommendations and/or standard installation specifications required by AASHTO and others. In addition, installation shall be as follows:

1. Installation – General

- a. Use equipment, methods, and materials ensuring installation to lines and grades indicated.
 - a.1. Maintain within tolerances specified or acceptable laying schedule.
 - a.2. Do not lay pipe on blocks unless pipe is to receive total concrete encasement.
 - a.3. Accomplish horizontal and vertical curve alignments with bends, bevels, and joint deflections.
 - o Limit interior joint opening in concrete pipe except for open side on deflected joints to:
 - (1) 3/8-inch in laying schedule.
 - (2) 1/2-inch in actual installation.
- b. Install pipe of size, materials, strength class, and joint type with embedment indicated for plan location.
- c. Begin installation at downstream end of line and install pipe with spigot or tongue ends in direction of flow. City's approval required for any deviations from this.
- d. Clean interior of all pipe, fittings, and joints prior to installation. Exclude entrance of foreign matter during installation and at discontinuance of installation.
 - d.1. Close open ends of pipe with snug-fitting closures.

- d.2. Do not let water fill trench. Include provisions to prevent flotation should water control measures prove inadequate.
 - d.3. Remove water, sand, mud, and other foreign materials from trench before removal of end cap.
 - e. Brace or anchor as required preventing displacement after establishing final position.
 - f. Perform only when weather and trench conditions are suitable. Do not lay pipe in water.
 - g. Adhere to confined space procedures.
2. Jointing
- a. General Requirements:
 - a.1. To provide for differential movement at impervious trench checks, structures, and changes in type of pipe bedding:
 - o No joints within 8-inches from structure wall.
 - o Support pipe from wall to first joint with concrete cradle structurally continuous with base slab or footing.
 - o As indicated by manufacturer or plans.
 - a.2. Place joints per manufacturer's recommendations.
 - a.3. Clean and lubricate all joint and gasket surfaces with lubricant recommended by pipe manufacturer.
 - a.4. Use methods and equipment capable of fully seating joints without damage.
 - a.5. Check joint opening and deflection for specification limits.
 - a.6. Excavate bell holes at each joint or coupling to provide full-length barrel support of the pipe and to prevent point loading at the bells or couplings.
 - b. Special Provision for Jointing Concrete Pipe:
 - b.1. With rubber gaskets:
 - o Check gasket position and condition with feeler gauge prior to installation of next section.
 - c. Special Provisions for Jointing PVC Pipe and HDPE Pipe:
 - c.1. Conform to ASTM D2321.
 - c.2. Connect pipe to new or existing rigid structures or manhole tie-ins with manhole couplings and a standard boot.
 - d. Special Provisions for Jointing ASP:
 - d.1. Connect pipe to new or existing rigid structures or manhole tie-ins with manhole couplings and a standard boot.
3. Pipe Cutting
- a. Pipe section shall not be damaged by cutting.
4. Temporary Plugs:

- 5.
 - a. Furnish and install temporary plugs at each end of Work for removal by others when work resumes. Plug must be secured in place and must be removable.
 - b. Plugs
 - b.1. Temporary plugs as supplied by pipe manufacturer.
 - b.2. Fabricated by Contractor of substantial construction.
 - b.3. Watertight against heads up to 20 feet of water.

- 6. Connections to existing structures:
 - a. Connect pipe to existing structures and pipelines where indicated.
 - b. Opening in structure shall have a minimum 3 inches clearance on all sides.
 - c. Adhere to pipe manufacturer's specifications.
 - d. Grout opening on inside with non-shrink grout.
 - e. Place structural concrete collar on outside.

7. Field Testing

- a. Acceptance Tests:
 - a.1. Alignment:
 - o Pipe shall be inspected by lamping the line or by physical passage where space permits.
 - o Contractor shall clean pipe of excess mortar, joint sealant, and other dirt and debris prior to inspection.
 - o Determine:
 - (1) Presence of any misaligned, displaced, or broken pipe.
 - (2) Presence of visible infiltration or other defects.

- b. Deflection Testing:
 - b.1 Maximum installed deflections of flexible pipe shall be as follows:

Type of Pipe	Deflection – Percent of Mean Internal Diameter
ASP & CMP	5
PVC	5
HDPE	5

- c. City shall require Contractor to test flexible pipe after backfill has been in place 30 days and again after eleven (11) months if deemed necessary.
 - c.1. Provide rigid ball or mandrel deflection testing equipment and labor.
 - c.2. Obtain approval of equipment and acceptance of method proposed for use. Test shall be performed without mechanical pulling devices.
 - c.3. Remove and replace pipe exceeding deflection limits

6.2.2.C BACKFILL AND COMPACTION

The backfill is the area above the pipe bedding. The pipe trench shall be backfilled and compacted in accordance with Volume 1, Street Design Standards and Construction Specifications, Section 02595, Utility Cut and Backfill.

Backfill material may be local site material that is well-graded, non-cohesive granular material free of rocks, frozen lumps, foreign material or stones greater than 3" in any dimension, aggregate base course, or flowfill. Remove all debris including soda cans, rags, pipe banding material, etc. from the pipe trench before backfilling.

In areas where a portion of the trench bottom is lower than the water table, line the trench and wrap the bedding material with a woven geotextile fabric meeting AASHTO M288 Specification for Class 2, Subsurface Drainage and Permanent Erosion Control. Lap fabric joints at least 12 inches. If the plans specify, furnish and install reinforced concrete cut-off walls at one hundred (100) foot intervals along the trench line.

Haunching is the area of bedding up to the pipe spring line. Granular material as outlined for the bedding shall be placed and consolidated evenly on each side of the pipe. The bedding materials shall be consolidated under the lower haunch of the pipe with shovel slicing and tamping. Care shall be taken to see that pipe alignment and cross-sectional areas are maintained.

Compaction machinery should not be used around flexible pipes until the select bedding is placed 12-inches over the top of the pipe and the first lift of backfill is placed.

6.2.2.D INSPECTION AND TESTING

Installation of the pipe bedding, haunching, and backfill up to a point 12-inches above the top of the pipe, shall be observed by the City. The City will provide acceptance testing during backfill operations. The Contractor shall take Quality Control tests in the pipe haunch area for pipe diameters 36-inches and larger. For pipes smaller than 36-inch diameter, begin tests at one foot above the pipe. Quality Control tests shall be taken as follows:

Schedules For Quality Control and Quality Assurance Sampling and Testing shall be per Streets Volume 1.

After backfill and compaction of the trench is completed, the pipe shall be inspected to detect any deformations, sags, or joint displacements. Rigid pipe shall be visually inspected for sags or displaced joints.

Upon completion of storm drain installation and prior to paving, the contractor shall notify the City. The Contractor shall be required to perform a pipe deflection test for flexible pipes with runs greater than 100' long in the presence of the City.

Flexible pipe, 48-inch diameter and smaller, may be tested with a "Go/No Go" deflection test gauge, which shall be pulled through the pipe. The maximum allowable deflection is 5 percent. The horizontal diameter shall not differ from the design diameter by more than 5 percent. Similarly, for pipes other than circular, the field-installed dimensions shall not vary more than 5 percent of the design dimensions. Any pipe that exceeds the maximum allowable deflection is to be removed and replaced.

The tests and inspection reports shall be submitted to the City prior to proceeding to the next phase of construction and prior to paving. The Contractor shall provide the City a letter of certification, prior to the issuance of building permits. The letter of certification shall state that the class, gauge, or stiffness of pipe is in accordance with the City's design for installation conditions encountered.

Inspection checklists for handling, storing, installing, and testing pipe are included at the end of this Section.

6.2.3 CONNECTIONS TO EXISTING STORM DRAIN

Connection to different pipe materials shall be made using manholes or transition sleeves. Details for connection to different materials shall be provided by the Design Engineer. If nothing is specified, a minimum of a structural concrete collar shall be installed.

6.2.4 PIPE INSPECTION CHECKLIST

Before unloading, inspect pipe and fittings for any obvious transportation damage.

Check each pipe section and fitting for proper markings on pipe.

Check for correct ASTM or AASHTO Specification.

Pipe diameter, class or strength designation.

Manufacturer or trade name.

Date of manufacture.

Number assigned to each pipe corresponding to laying diagram if required.

Check each pipe section for external and internal damage.

Check gaskets for damage and proper markings or identifications.

Check that all pre-inserted gaskets are in place.

Check lubricants, cleaners, or adhesives for conformance.

Check flexible pipe for axial or longitudinal deformation.

Mark each pipe that is rejected or needs to be repaired to prevent usage.

Compare field repair procedures with manufacturer's requirements.

Document repairs with photos, names of personnel, dates, equipment, and supplies.

Pipe stored in accordance with manufacturer's instructions.

Pipe stored on flat area, with joints supported.

Pipe shall not be stacked higher than allowed by manufacturer.

Procedures followed that will not allow the pipe to become deformed during storage.

All blocks, chocks, wedges are intact and firmly in place.

PVC/HDPE pipe is protected from long-term (greater than 30 days) exposure to sunlight.

Pipe is protected from adverse weather, harmful chemicals, dirt or debris accumulating on the interior of the pipe.

Gaskets are protected from dust and grit, solvents, and petroleum-based greases and oils, and other agents having a harmful effect on the gasket.

Stringing of pipe is in accordance with manufacturer's recommendations.

Pipes are blocked to prevent movement due to wind or accidental bumping.

Pipe joining surfaces shall be cleaned of any dust, dirt, and debris accumulation prior to installing gasket and joining.

Interior of pipe is free of dirt and debris.

Access to roads, driveways, etc., shall be maintained.

If stringing of pipe is required along roadway, is pipe orientated (angular rotation) properly, is pipe a safe distance from traffic, and is proper flasher signage present to protect traveling public.

6.2.5 PIPE INSTALLATION CHECKLIST

Pipe is correct type, diameter, strength, (class, SDR, gauge, etc).

Pipe numbers and stationing checked against lay schedule.

Pipe re-inspected for damage.

Pipe cleaned of debris in interior and on gasket sealing surfaces.

Pipe shall not be laid uphill on grades that exceed 10% (or less if specified).

Pipe with marked field top laid with top up.

Contractor continually checks alignment and grade of pipeline.

Ends of pipe sealed at close of work or for shut-down periods.

Bedding material shall meet specifications.

Compaction requirements are met.

Frequency of testing the bedding material conforms to specifications.

Bedding material checked for compatibility with other trench materials to prevent soil migration in groundwater areas.

Trench bottom is free from loose rocks, large dirt clods, and debris.

Bedding material free from organic matter, stumps or limbs, frozen earth, debris, refuse, or other unsuitable material.

Minimum bedding thickness met. Required thickness = _____.

Bedding surface is at the proper elevation so that pipe will be placed on grade.

Bedding is placed so that barrel of pipe has uniform support.

Blocking or mounding shall not be used to bring pipe to grade.

Bell holes and/or sling holes excavated.

Clearance between bell and bedding checked.

If high groundwater table present, floating may become a problem during installation of flexible pipelines. Trench must be dewatered during installation.

Special attention given to HDPE pipe during times of high temperature to ensure increased pipe flexibility does not cause excessive deflection.

PVC and HDPE may become brittle during cold weather. Avoid impact damage.

6.2.6 SUB-SURFACE UTILITY ENGINEERING

In response to Senate Bill 18-167, public storm drains must be electronically locatable. The City has the ability to electronically locate most storm drains without the use of installed tracer wire by manually inserting technology into storm drains during locates. As such, tracer wire is not required on all public storm drain installations.

Atypical installations may not be easily accessible for locating with this method; these would therefore require tracer wire. Conditions where tracer wire is required include:

- Storm drains installed 15 feet or greater below grade
- Public storm drains smaller than 18" in diameter
- Storm drains with horizontal bends or deflections without an access point
- Storm drains with greater than 400 feet between access points
- Any storm drain that is otherwise not accessible between straight runs

Should any one of these conditions exist, tracer wire and test stations shall be installed on the storm drain segment. Consultation with the Stormwater Management Division shall be required to provide specifications for this activity.

6.2.7 DRAWINGS OF RECORD (AS-BUILTS)

Detailed drawings shall be prepared by the Design Engineer, upon completion of work. (For Capital Improvement Projects where the Contractor is responsible for the Drawings of Record, the Drawings of Record shall be completed prior to issuance of the Substantial Completion). Drawings shall contain field dimensions, elevations, details, changes made to the construction drawings by modification, details which were not included on the construction drawings, and horizontal and vertical locations of underground utilities which have been impacted by the utility installation.

Maintain record drawings in clean, dry, legible conditions and in good order. Do not use record documents for construction purposes.

Record as-built information concurrently with construction progress. Do not backfill work until required information is recorded.

As-built record drawings shall be submitted to the City for approval on 24"x36" black line form.

6.3 HYDRAULIC DESIGN

Storm drains shall be designed to convey initial storm peaks without surcharging the pipe. To ensure that this objective is achieved, the hydraulic grade line shall be calculated by accounting for pipe friction losses and pipe form losses. Total hydraulic losses will include friction, expansion, contraction, bend, and junction losses. The final energy grade line shall be at or below the proposed ground surface. The methods for estimating the hydraulic losses are presented in the following sections.

6.3.1 PIPE FRICTION LOSSES

The Manning's "n" values to be used in the calculation of storm drain capacity are presented in Table 6-1 for concrete and plastic pipe and Table 9-1 for corrugated metal pipe.

6.3.2 PIPE FORM LOSSES

Generally, between the inlet and outlet the flow encounters a variety of configurations in the flow passageway such as changes in pipe size, branches, bends, junctions, expansions, and contractions. These shape variations impose losses in addition to those resulting from

pipe friction. Form losses are the result of fully developed turbulence and can be expressed as follows:

$H_L = K (V^2 / 2g)$	Equation 6.3.2
<p>Where:</p>	H_L = head loss (feet) K = loss coefficient $\frac{V^2}{2g}$ = velocity head (feet) g = gravitational acceleration (32.2 ft/sec ²)

The following is a discussion of a few of the common types of form losses encountered in stormwater system design. The user is referred to the USDCM or other professional manuals for additional discussion.

6.3.2.A EXPANSION LOSSES

Expansion in a storm drain conduit will result in a shearing action between the incoming high velocity jet and the surrounding pipe boundary. As a result, much of the kinetic energy is dissipated by eddy currents and turbulence. The loss of head can be expressed as:

$H_L = K_e (V_1^2 / 2g) [1 - A_1 / A_2]^2$	Equation 6.3.2.A
--	------------------

In which A is the cross section area, V is the average flow velocity, and K_e is the loss coefficient. Subscripts 1 and 2 denote the upstream and downstream sections, respectively. The value of K_e is about 1.0 for a sudden expansion, and about 0.2 for a well-designed expansion transition. Table 6-2 presents the expansion loss coefficients for various flow conditions.

6.3.2.B CONTRACTION LOSSES

The form loss due to contraction is:

$H_L = K_c (V_2^2 / 2g) [1 - (A_2)^2 / A_1]^2$	Equation 6.3.2.B
--	------------------

Where K_c is the contraction coefficient. K_c is equal to 0.5 for a sudden contraction and about 0.1 for a well-designed transition. Subscripts 1 and 2 denote the upstream and downstream sections, respectively. Table 6-2 presents the contraction loss coefficients for various flow conditions.

6.3.2.C BEND LOSSES

The head losses for bends, in excess of that caused by an equivalent length of straight pipe, may be expressed by the relation:

$$H_L = K_b (V^2/2g)$$

Equation 6.3.2.C

In which K_b is the bend coefficient. The bend coefficient has been found to be a function of: (a) the ratio of the radius of curvature of the bend to the width of the conduit, (b) deflection angle of the conduit, (c) geometry of the cross section of flow, and (d) the Reynolds Number and relative roughness. A tabulation of the recommended bend loss coefficients for standard bends, radius pipe, and bend through manholes is presented in Tables 6-3 and 6-4.

6.3.2.D JUNCTION AND MANHOLE LOSSES

A junction occurs where one or more branch drains enter a main drain, usually at manholes. The hydraulic design of a junction is in effect the design of two or more transitions, one for each flow path. Allowances should be made for head loss due to the impact at junctions. The head loss for a straight through manhole or at an inlet entering the storm drain is calculated from the original equation for form losses (Equation 6.3.2). The head loss at a junction can be calculated from:

$$H_L = (V_2^2/2g) - K_j (V_1^2/2g)$$

Equation 6.3.2.D

Where V_2 is the outfall flow velocity and V_1 is the inlet velocity. The loss coefficient, K_j , for various junctions is presented in Table 6-5.

6.3.3 STORMWATER OUTLETS

When the stormwater system discharges into the Major Drainage way system (usually an open channel), additional losses occur at the outlet in the form of expansion losses (refer to Section 6.3.2.A). For a headwall and no wing walls, the loss coefficient $K_e = 1.0$ (refer to Table 6-2), and for a flared-end section the loss coefficient is approximately 0.5 or less.

6.3.4 PARTIALLY FULL PIPE FLOW

When a storm drain is not flowing full, the drain acts like an open channel, and the hydraulic properties can be calculated using open channel techniques (refer to Section 5). For convenience, charts for various pipe shapes have been developed for calculating the hydraulic properties (Figures 6-1, 6-2, and 6-3). The data presented assumes that the friction coefficient, Manning's "n" value, does not vary throughout the depth.

6.3.5 HYDRAULIC RESEARCH

The American Public Works Association (APWA) has conducted research into the head losses at various junctions and manholes. The work consisted of experimentally modeling three types of pipe junctions: junctions with a 90 degree bend, junctions of a main with a perpendicular lateral, and junctions of two opposed laterals. The work was primarily directed at sanitary sewers because the sizes investigated (i.e., manhole diameter to sewer diameter ratio of 2.3 to 4.6) and the flow conditions (i.e., pressure flow) were typical for sanitary sewers. However, several trends were observed that are considered to be suitable for storm drains, including specific energy loss coefficients that have been adopted for these Criteria. The trends observed from the test results are as follows:

1. For manhole diameter to pipe diameter ratios between two (2) and six (6), the variation in head loss was insignificant.
2. The most significant reduction in head loss occurs when the manhole is shaped by benching the bottom of the manhole up to the top of the pipe. This appears to provide a better channelization of the flow, which reduces the losses.
3. Some testing was also performed for open channel flow conditions. These tests generally showed that the energy losses were less than for pressure flow. Since most storm drains are not pressurized, the use of the coefficients should be conservative.

This information is presented to aid the Designer in selecting suitable energy loss coefficients for situations not covered by these Criteria.

6.4 VERTICAL ALIGNMENT

The storm pipe grade shall be such that a minimum cover is maintained to withstand AASHTO HS-20 loading (or as designated by the Public Works Department). The minimum cover depends upon the pipe size, type and class, and soil bedding condition, but shall not be less than 12 inches on any point along the pipe.

The minimum clearance between storm drain and water main, in open cuts, either above or below, shall be eighteen (18) inches. In addition, when a water line lies below a storm line, or within 24 inches above, the storm line joints shall be grouted for a minimum of 10 feet on each side of the crossing. Storm line shall be installed so that a joint is not directly above or below the water main. Storm pipe shall be centered over or under the water main.

The minimum clearance between storm drain and sanitary sewer, either above or below, shall also be eighteen (18) inches. In addition, when a sanitary sewer main lies above a storm drain, or within 18 inches below, the sanitary sewer shall have an approved encasement or be constructed of structural sewer pipe for a minimum of 10 feet on each side of where the storm drain crosses. Storm line shall be installed so that a joint is not directly above or below the sewer main. Storm pipe shall be centered over or under the sewer main.

Horizontal boring installation of utilities shall require a minimum of three feet of vertical clearance from storm drain facilities, if installed below the storm drain. A minimum of two feet of vertical clearance is required above an existing storm drain. Crossings of existing storm drains shall be perpendicular to the greatest extent practicable. These installations must meet City of Greeley Crossing Permit requirements. If required vertical separation cannot be achieved, the City shall be contacted immediately to review the situation.

6.5 HORIZONTAL ALIGNMENT

Storm drain alignment between manholes shall be straight for storm drains less than 48-inches in diameter. Storm drains may be constructed with curvilinear alignment for 48-inch diameter and larger pipe by either the pulled joint method or by radius pipe in accordance with Table 6-1. The limitations on the radius for pulled joint pipe are dependent on the pipe length and diameter, and amount of opening permitted in the joint. The maximum allowable joint pull shall be $\frac{3}{4}$ of an inch. The minimum parameters for radius type pipe are shown in Table 6-1. The radius requirement for pipe bends is dependent upon the manufacturer's specifications.

The minimum horizontal separation between storm drains or sanitary sewers and water lines shall be 10 feet.

Horizontal boring installation of utilities shall require a minimum of ten feet horizontal separation from the *outside wall* of a storm drain. These installations must meet City of Greeley Crossing Permit requirements. If ten (10) foot horizontal separation cannot be achieved, the City shall be contacted immediately to review the situation.

6.6 PIPE SIZE

The minimum allowable pipe size for storm drains, except for detention outlets, shall be 18 inches in diameter and shall be round pipe. Table 6-1 presents the minimum pipe size for storm drains.

6.7 MANHOLES

6.7.1 GENERAL INFORMATION

Manholes or maintenance access ports shall be required whenever there is a change in size, direction, elevation, grade, or where there is a junction of two or more storm pipes. A manhole may be required at the beginning and/or at the end of the curved section of storm drain. The maximum spacing between manholes for various pipe sizes shall be in accordance with Table 6-1.

The required manhole size shall be as follows:

TABLE 6.7.1 – MANHOLE SIZE

MANHOLE SIZE	
Storm Pipe Diameter	Manhole Diameter
15" to 18"	4'
21" to 30"	5'
36" to 54"	6'
60" and larger	CDOT Standard M-604-20

Larger manhole diameters or a junction structure may be required when storm pipe alignments are not straight through or more than one storm pipe line goes through the manhole.

6.7.2 MANHOLE MATERIALS

6.7.2.A MANHOLE

All materials, manufacturing operations, testing and inspection of manholes shall conform to the requirements of:

ASTM C 478M(C478) Precast Reinforced Concrete Manhole Risers (AASHTO M199) and Tops.

All precast concrete materials shall conform to Section 712.05 - Precast concrete units and all poured in place concrete manholes or vaults shall conform to or exceed Metropolitan Government Engineer's Council (MGPEC) specifications Item 11, Portland Cement Concrete Pavement; Section 11.2, Materials.

Rebar shall conform to the latest edition of American Concrete Institute 318-89 (ACI 318-89) or 602 - Reinforcing Steel, CDOT Standard Specifications for Road and Bridge Construction.

Manholes shall consist of precast riser sections, top or cone section, precast adjusting rings, precast or field poured base, steps and rings and covers. Manholes shall be constructed in accordance with the DCCS Standard Details or as shown on the Plans.

Precast concrete manholes shall be of the eccentric, concentric or flat top type as described in the Standard Details. Manholes shall be of the diameter and depth shown on the Plans. Manholes in excess of 20 feet depth shall have an intermediate platform located at the approximate center of the depth (See Detail 6-11).

Riser and top sections shall be precast reinforced concrete.

Adjusting rings shall be reinforced with the same percentage of steel as the riser and top.

6.7.2.B STEPS

Steps shall be required when the manhole depth exceeds 3'-6" and shall be in accordance with AASHTO M 199. Steps shall be firmly embedded in the wall of each manhole riser and cone section. Steps shall withstand vertical loads of 400 pounds. Steps shall be placed in a straight line and be uniformly spaced. Steps shall be positioned to allow 20 to 26 inches spacing from the rim to the first step, and spacing thereafter shall be not less than 12 inches or more than 15 inches center to center.

Steps may be aluminum alloy conforming to Federal Specification QQ-A-200/8 and shall be equal to Alcoa No. 12653B, or may be a step comprised of a minimum 3/8-inch diameter grade 60 steel reinforcing rod completely encapsulated in polypropylene, as manufactured by M.A. Industries, Inc. or equal. M.A. steps shall be either type PS-2PF or PS-2-PFS. Plastic manhole steps shall conform to ASTM C-478. Steps in riser sections shall project from the wall not less than 6-5/8 inches.

Steps in cone sections shall project from the wall not less than 4-7/8 inches. All steps shall penetrate the wall not less than 3-3/8 inches.

6.7.2.C RINGS AND COVERS

Iron manhole rings and covers shall be the best quality gray iron, tough and even grain, and when cast, shall be free from faults, blowholes, or other defects, and shall possess a tensile strength of not less than 35,000 psi. Rings and covers shall be designed to withstand the traffic loads that will be imposed upon them. Rings and covers shall be manufactured for current CDOT Standards 712.06 and meet the requirements shown on Detail 6-8.

The horizontal bearing surfaces of the ring and cover shall be machined so that they will not shift under traffic. Covers, which do not rest solidly in the frames, will not be accepted.

Manhole rings and covers shall be in accordance with the City of Greeley Standards. Covers shall be non-perforated, and shall show the lettering as indicated on Detail 6-8.

When a manhole is located in a pavement area, it shall not be brought to final grade until the pavement has been completed.

6.7.2.D MANHOLE GASKETS

Where preformed, flexible plastic gaskets shall be used to seal joints between precast manhole sections, they shall conform to Federal Specifications SS-S-00210 (6SA-FSS), Type I, Rope Form, and shall have a minimum diameter of 1-1/2 inches. Gaskets shall be

applied to the tongue and shoulder lips of the precast section, providing two (2) gaskets per joint. "RUB'R NEK" or "KENT SEAL" or approved equal products shall be used.

6.7.3 MANHOLE CONSTRUCTION

The work covered by this Subsection consists of constructing precast, preassembled or field assembled manholes for storm drain construction. Construction consists of excavation; shoring; dewatering; subgrade preparation; construction of base; placement and assembly of risers, cone, or tops; installation of ring, cover and adjusting rings; backfilling; surface restoration and other related work. The following quality standards shall apply:

ASTM C 891: Installation of Underground Precast Concrete Utility Structures.

6.7.3.A MATERIALS

The Contractor shall install manholes of the dimensions shown on the Plans. All materials used shall conform to the requirements of Section 6.7.2 above.

6.7.3.B SURFACE PREPARATION, EXCAVATION, DEWATERING

Surface preparation, excavation and dewatering shall conform to the requirements cited in Volume I - Streets - Design Criteria and Construction Specifications.

6.7.3.C MANHOLE BASE

Manhole bases shall be precast or field poured as detailed on standard details but never less than 8" thick below the invert. Concrete shall conform to or exceed Metropolitan Government Engineer's Council (MGPEC) specifications Item 11, Portland Cement Concrete Pavement; Section 11.2, Materials.

Rebar shall conform to the latest edition of American Concrete Institute 318-89 (ACI 318-89) or 602-Reinforcing Steel (for larger manholes, See Detail 6-9), CDOT Standard Specifications for Road and Bridge Construction. Concrete shall be consolidated and struck-off to a horizontal surface within the forms or pouring rings.

Invert channels shall be smooth and semi-circular in shape conforming to the inside of the adjacent storm pipe section. Changes in direction of flow in manholes with only one entering storm pipe shall be made per Details 6-9 & 6-10. Changes in size and grade of the channels shall be made gradually and evenly. Channels in bases of manholes at intersections of storm pipes shall follow the alignment of the storm pipes. The invert channels may be formed directly in the concrete of the manhole base or may be half-pipe laid in concrete. Flow entering into and passing through the manhole shall be unobstructed. Liquid or solids shall not be retained by the manhole or adjoining pipe. The floor of the manhole outside the channel shall be broomed and shall slope toward the channel not less than one inch per foot, nor more than two inches per foot.

Field poured concrete bases for 4' dia. or larger manholes shall be reinforced as detailed on the Plans or as shown on Details 6-9 & 6-10.

Precast reinforced concrete bases shall be of the size and shape detailed on the Plans or as shown on Details 6-9 & 6-10.

Precast sections which appear to be porous, honeycombed, cracked, chipped, out-of-round, have exposed rebar, or are otherwise defective shall be rejected.

6.7.3.D MANHOLE BARRELS

Manhole barrels shall be assembled of precast riser sections. Riser sections shall be placed vertically with tongue and groove properly keyed. Ladder rungs shall be vertically aligned and equally spaces in the finished manhole. The top step shall be placed so that

it is between 20 and 26 inches below the finished rim elevation. Barrel sections that appear to be porous, honeycombed, out-of-round, cracked, chipped, have exposed rebar, or are otherwise deformed or damaged shall be rejected.

Intermediate platforms shall be assembled for manholes that are over 20 feet in depth (see Detail 6-11).

Free drop inside the manhole shall not exceed five feet measured from the invert of the inlet pipe to the invert of the outlet pipe. Where the drop exceeds five feet, inside drop manholes shall be constructed as detailed on the Plans or as approved by the City.

All connections between the riser or base sections and the storm pipe shall be joined in such a manner as to make the manhole watertight. Preformed rubber water stop gasket cast into the riser or base section is an acceptable joining method.

Preformed flexible plastic sealing compounds similar or equal to "Rub'R Nek" or "Kent Seal" are acceptable, provided acceptable water tightness is achieved.

6.7.3.E TOP OR CONE SECTIONS

Flat top sections may be used on a shallow manhole. Otherwise, cone sections shall be installed for heights exceeding 8 feet (see Figure 6-9 for more detail).

Cone shaped top sections shall be assembled on top of the manhole barrel with tongues and grooves properly keyed. Ladder rungs shall be equally spaced and vertically aligned in the finished manhole. The top ladder rung shall be installed to an elevation in accordance with Figure 6-9.

Concrete grade rings may be used for adjusting the manhole lid elevation. The total height from the top of cone to top of frame shall not exceed 16 inches. Metal adjusting grade rings are not allowed. Broken concrete grade rings shall be rejected.

4500 psi (min) non-shrink grout, shall be placed under and between the metal ring and adjusting grade rings, and between adjusting grade rings and the cone section. For manholes in open areas, grass or on gravel roads, concrete grout shall surround the metal ring and adjusting grade rings; the grout shall be formed horizontally to the outside diameter of the cone section and vertically to the rim elevation, in accordance with Detail 6-9. Install manhole lid to the ground surface in an open area or grass area. In gravel roads, leave the lid 6-inches below the road surface. For manholes in paved (asphalt or concrete) streets or other paved areas, install a concrete collar in accordance with Section 02610, Manhole and Valve Box Adjustment and Detail No. S-34 (City of Greeley DCCS, Volume I - Streets).

6.7.3.F WATERTIGHTNESS

The finished manhole is expected to be as watertight as the pipe system it is incorporated into. Observed leaks shall be cause for rejection.

All connections between riser sections, bases, tops, and rings shall be sealed with preformed flexible plastic joint sealing compound. Application of sealing compound shall be accomplished in conformance with the manufacturer's recommendations. Grade of materials, quantity of materials and application temperatures recommended by the manufacturer shall govern. Sealing compound similar or equal to "Rub 'R Nek" or "Kent Seal" shall be used.

6.7.3.G CONNECTIONS

All connections of pipe to manhole shall be made with a proper water stop. Mains tapped into manholes shall be constructed so that the flow entering the manhole is channeled through the bench into the invert of the manhole under all flow conditions.

6.7.3.H BEDDING AND BACKFILLING

Bedding, backfilling, and surface restoration around manholes shall conform to the requirements of DCCS Streets, Volume 1, Section 02223. Bedding material shall be placed up to a point equal to that required for the adjacent pipe.

6.7.3.I QUALITY CONTROL

Inspection, testing, approval and acceptance shall conform to the requirements of Volume I - Streets - Design Criteria and Construction Specifications.

Materials not inspected by the City or damaged by an action of the Contractor shall be subsequently rejected and replaced at the Contractor's expense.

Materials inspected by the City, installed by the Contractor and found to be damaged through no fault of the Contractor shall be repaired or rejected and replaced at the Developer's expense.

6.7.3.J CLEAN UP

All rubbish, unused materials and other non-native materials shall be removed from the job site. All excess excavation shall be disposed of as specified, and the right-of-way shall be left in a state of order and cleanliness. Manholes and pipelines shall be free of dirt, scum, gravel, excess grout, and other foreign material.

6.8 STORMCEPTOR – OIL/SEDIMENT IN-LINE SEPARATOR UNIT

The oil/sediment separator unit shall be a "Stormceptor®" model or approved equal. Other types of "Stormceptor® type" products meeting the criteria below are acceptable upon special review.

The separator shall remove oil and sediment from stormwater during frequent wet weather events. The separator shall treat a minimum of 75 to 90 percent of the annual runoff volume and be capable of removing up to 80 percent of the total suspended sediment load (TSS) and greater than 90 percent of the floatable free oil. The separator must be capable of trapping silt and clay size particles in addition to large particles and local TSS load reduction requirements. The separator shall be installed underground as part of the storm drain system and be structurally designed for traffic loading (HS-20 min) at the surface. The separator shall be maintainable from the surface via one or more access points.

The separator shall be equipped with a high flow bypass that regulates the flow rate into the treatment chamber and conveys high flows directly to the outlet such that scour and/or re-suspension of material previously collected in the separator does not occur. The bypass area shall be physically separated from the separation area to prevent mixing. The concrete portion of the separator shall be designed and manufactured in accordance with ASTM C-478. The concrete joints shall be oil resistant, water tight and meet the design criteria according to ASTM C-443. If a concrete separator is specified, it should be lined with an oil resistant material or coating for a minimum oil depth of 12 inches to provide secondary containment of any hydrocarbon materials.

The difference between the inlet pipe elevation to the separator and the outlet pipe elevation from the separator shall be minimized to allow installations into existing systems. The separator should be able to be used as a bend structure in the storm drain system. The access

cover for all non-inlet type separators should clearly indicate that it is an oil/sediment separator.

The separator shall be capable of containing spills of floatable substances such as free oil and not be compromised by temporary backwater conditions (i.e., trapped pollutants should not be re-suspended and scoured from the separator during backwater conditions).

The capabilities of the selected separator must be documented with scientific studies and reports.

6.9 MAINTENANCE AND ACCESS EASEMENTS

An important aspect of stormwater operation is the continued maintenance of the infrastructure to ensure that it will continue to function as designed. Maintenance may include cleaning of trash racks, inlet and outlet structures, and the removal of sediment and debris from the storm drains.

The City requires that maintenance access be provided to all storm drainage infrastructure. The following minimum easement widths, which must be shown on the Final Plat, (or provided by separate document) are required:

TABLE 6.9 – REQUIRED STORM DRAIN MAINTENANCE AND ACCESS EASEMENTS

REQUIRED STORM DRAIN MAINTENANCE AND ACCESS EASEMENTS	
Storm Pipe Diameter	Easement Width
Less than 36"	20'
Equal to or greater than 36"	25' (with pipe placed at the 1/3 point in the easement)

Long term operation and maintenance of detention ponds can be found in these Criteria in Section 12 – Stormwater Quality Enhancement.

6.10 DESIGN EXAMPLE

The following calculation example, including the calculation Table 6-6, and Figures 6-4 and 6-5, were obtained from Modern Sewer Design, AISI, Washington D.C., 1980 and edited for the calculation of manhole and junction losses in accordance with this Section.

Given:

(a) Plan and Profile of storm pipe (Figures 6-4 and 6-5), example calculation form (Table 6-6).

(b) Station 0+00 (outfall) data as follows:

Design Discharge	Q	= 145 cfs	(Column 9)
Invert of Pipe		= 94.50 feet	(Column 2)
Diameter	D	= 66 inch RCP	(Column 3)
Starting Water Surface	W.S.	= 100 feet	(Column 4)
Area of Pipe	A	= 23.76 SF	(Column 6)
Velocity = Q/A	V	= 6.1 fps	(Column 8)
Pipe Roughness	n	= 0.013	

Notes:

(i) Numbers in brackets refer to the Columns on Table 6-6.

(ii) Sizes of the storm drain were determined during the preliminary design phase.

Find: Hydraulic Grade Line and Energy Grade Line for storm drain.

Discussion: The following procedure is based on full-flow pipe conditions. If the pipe is flowing substantially full (i.e., greater than 80 percent), the following procedures can be used with minimal loss of accuracy. However, the Design Engineer is responsible for checking the assumptions (i.e., check for full flow) to assure that the calculations are correct.

STEP 1: The normal depth is greater than critical depth, $d_n > d_c$; therefore, calculations to begin at outfall, working upstream. Compute the following parameters:

$$\phi = \frac{2gn^2}{2.21} = \frac{2 \times 32.2 \times (.013)^2}{2.21}$$

This equation is derived from the Manning's equation by solving for velocity and converting to velocity head.

$$\phi = 0.00492$$

This value remains constant for this design since the n-value does not change.

STEP 2: Velocity Head (Column 10):

$$H_v = \frac{V^2}{2g} = \frac{(6.1)^2}{(2)(32.2)}$$

$$H_v = 0.58$$

STEP 3: Energy Grade Point, E.G. (Column 11):

$$\text{E.G.} = \text{W.S.} + H_v = 100 + 0.58$$

$$\text{E.G.} = 100.58$$

For the initial calculation, the Energy Grade Line is computed as described above. For subsequent calculations, the equation is reversed, and the water surface is calculated as follows (see Step 12):

$$\text{W.S.} = \text{E.G.} - H_v$$

This equation is used since the losses computed in Step 8 are energy losses which are added to the downstream energy grade elevation as the new starting point from which the velocity head is subtracted as shown above.

STEP 4:

$$S_f = \frac{\phi H_v}{R^{4/3}} = \frac{(.00492)(0.58)}{(1.375)^{4/3}}$$

$$S_f = .0019$$

Note: R = the hydraulic radius of the pipe

STEP 5: Avg S_f (Column 13):

Average skin friction: This is the average value between S_f of the station being calculated and the previous station. For the first station, Avg $S_f = S_f$. Beginning with Column 13, the entrees are placed in the next row since they represent the calculated losses between two stations.

STEP 6: Enter drain length, L, in Column 14.

STEP 7: Friction loss H_f (Column 15):

$$H_f = (\text{Avg } S_f)(L)$$

$$H_f = (.0019)(110)$$

$$H_f = 0.21$$

STEP 8: Calculate the form losses for bends, junctions, manholes, and transition losses (expansion or contraction) using the appropriate equations. The calculation of these losses is presented below for the various pipe segments since all the losses do not occur for one pipe segment.

(a) Station 1 + 10 to 1 + 52.4 (bend)

$H_b = K_b H_v$, where the degree of bend is 60 degrees

$$K_b = 0.20 \text{ \{Table 6-3, Case I\}}$$

$$H_b = (0.20)(0.58) = 0.12 \text{ (Enter in Column 16)}$$

(b) Station 2 + 48 to 2 + 55.5 (transition, expansion)

$$H_L = K_e H_{v1} [1 - A_1/A_2]$$

$$K_e = 1.06 \text{ \{Table 6-2\} for } D_2/D_1 = 1.5, \text{ and } \phi = 45$$

$$H_L = (1.06) 1.29 [1 - 15.9/23.76]^2 = 0.15 \text{ (Enter in Column 19)}$$

(c) Station 3 + 55.5 (manhole, straight through)

$$H_m = K_m H_v \text{ (Note: } K_m = K_j)$$

$$K_m = (0.05) \text{ \{Table 6-5, Case I\}}$$

$$H_m = (0.05)(1.29) = 0.06 \text{ (Enter in Column 18)}$$

(d) Station 4 + 55.5 to 4 + 65.5 (junction)

$$H_j = H_{v2} - K_j H_{v1}$$

$$K_j = 0.62 \text{ \{Table 6-5, Case III\} } \phi = 30 \text{ degrees}$$

$$H_j = 1.29 - (.66)(0.99) = 0.64 \text{ (Enter in Column 17)}$$

(e) Station 5 + 65.5 to 5 + 75.5 (junction) since there are two laterals, the loss is estimated as twice the loss for one lateral

$$K_j = 0.33 \text{ \{Table 6-5, Case III\} } \phi = 70 \text{ degrees}$$

$$H_j = 0.99 - (0.33)(0.64) = 0.78 \text{ for one lateral}$$

STEP 9: Sum all the form losses from Columns 15 through 19 and enter in Column 20. For the reach between Station 0+00 and 1+10, the total loss is 0.21

STEP 10: Add the total loss in Column 20 to the energy grade at the downstream end (Sta 0+00) to compute the energy grade at the upstream end (Sta 1+10) for this example.

$$\text{E.G. (U/S)} = \text{E.G. (D/S)} + \text{TOTAL LOSS}$$

$$= 100.58 + 0.21$$

$$= 100.79 \text{ (Column 11)}$$

Where: E.G. = energy grade
U/S = upstream
D/S = downstream

STEP 11: Enter the new invert (Column 2), pipe diameter D (Column 3), pipe shape (Column 5), pipe area A (Column 6), then compute the constant ϕ from Step 1 in Column 7, the computed velocity V in Column 8, the new Q (Column 9), and the computed velocity head H_v (Column 10).

STEP 12: Compute the new water surface, W.S., for the upstream station (Station 1+10 for this example).

$$\begin{aligned} \text{W.S.} &= \text{E.G.} - H_v \\ &= 100.79 - 0.58 \\ &= 100.21 \text{ (Column 4)} \end{aligned}$$

STEP 13: Repeat Steps 1 through 12 until the design is complete. The hydraulic grade line and the energy grade line are plotted on the profile (see Figure 6-5).

DISCUSSION OF RESULTS:

The hydraulic grade line (HGL) is at the crown of the pipe from Station 0+00 to 2+48. Upstream of the transition (Station 2+55.5), the 54-inch RCP has a greater capacity (approximately 175 cfs) at that slope than the design flow (145 cfs). The pipe is therefore not flowing full but is substantially full (i.e., $145/175 = 0.84$, greater than 0.80). The computed HGL is below the crown of the pipe. However, at the outlet, the actual HGL is higher, since the outlet of the 54-inch RCP is submerged by the headwater for the 66-inch RCP. To compute the actual profile, a backwater calculation would be required; however this accuracy is not necessary for stormwater design in most cases.

At the junction (Station 4+55.5), the HGL is below the top of the pipe. However, in this case, the full flow capacity (100 cfs) is the same as the design capacity, and the HGL remains parallel to the top of the pipe. A similar situation occurs at the junction at Station 5+65.5 except that the HGL remains above and parallel to the top of the pipe.

If the pipe entering a manhole or junction is at an elevation significantly above the manhole invert, a discontinuity in the EGL may occur. If the EGL of the incoming pipe for the design flow condition is higher than the EGL in the manhole, then a discontinuity exists, and the higher EGL is used for the incoming pipe.

6.11 CHECKLIST

To aid the Designer and Reviewer, the following checklist has been prepared:

Calculate the energy grade line (EGL) and hydraulic grade line (HGL) for all storm drains and include calculations in the drainage report.

Account for all losses in the EGL calculation including outlet, form, bend, manhole, and junction losses.

Provide adequate protection at the outlet of all storm pipes into open channels.

Check for minimum pipe cover and clearance with all utilities.

VERTICAL DIMENSION
OF PIPE (INCHES)

15 TO 36
42 AND LARGER

MAXIMUM ALLOWABLE DISTANCE
BETWEEN MANHOLES AND/OR CLEANOUTS

400 FEET
500 FEET

MINIMUM RADIUS FOR RADIUS PIPE

DIAMETER OF PIPE

48" TO 54"
57" TO 72"
78" TO 108"

RADIUS OF CURVATURE

28.50 FEET
32.00 FEET
38.00 FEET

SHORT RADIUS BENDS SHALL NOT BE USED ON
PIPES 42 INCHES OR LESS IN DIAMETER

MINIMUM PIPE DIAMETER

<u>TYPE</u>	<u>MINIMUM EQUIVALENT PIPE DIAMETER</u>	<u>MINIMUM CROSS- SECTIONAL AREA</u>
MAIN TRUNK *LATERAL FROM INLET	18 INCHES	1.77 SQ. FT.

*MINIMUM SIZE OF LATERAL SHALL ALSO BE BASED UPON A WATER
SURFACE INSIDE THE INLET WITH A MINIMUM DISTANCE OF 1 FOOT
BELOW THE GRATE OR THROAT

MANNING'S N-VALUE

<u>PIPE TYPE</u>	<u>CAPACITY CALCULATION</u>	<u>VELOCITY CALCULATION</u>
CONCRETE (NEWER PIPE)	.013	.011
CONCRETE (OLDER PIPE)	.015	.012
CONCRETE (PRELIMINARY SIZING)	.015	.012
PLASTIC	.012	.009
ALUMINIZED STEEL (ASP)	.012	.011

STORM PIPE ALIGNMENT AND SIZE CRITERIA

TABLE 6-1

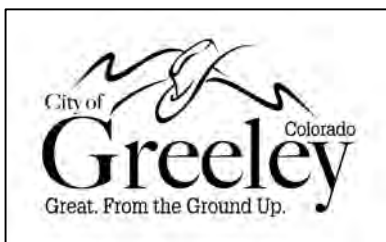

EXPANSION/CONTRACTION

(a) EXPANSION (K_e)

θ^*	$\frac{D_2}{D_1} = 3$	$\frac{D_2}{D_1} = 1.5$
10	0.17	0.17
20	0.40	0.40
45	0.86	1.06
60	1.02	1.21
90	1.06	1.14
120	1.04	1.07
180	1.00	1.00

* THE ANGLE θ IS THE ANGLE IN DEGREES BETWEEN THE SIDES OF THE TAPERING SECTION

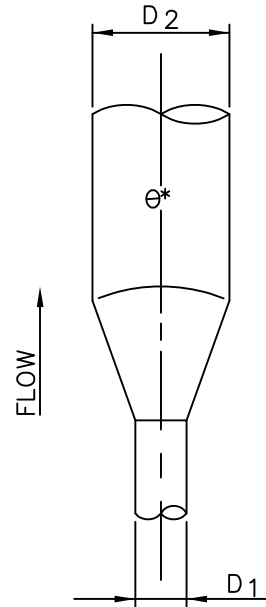

(b) PIPE ENTRANCE FROM RESERVOIR

BELL-MOUTH $H_L = 0.04 \frac{V^2}{2g}$

SQUARE EDGE $H_L = 0.5 \frac{V^2}{2g}$

GROOVE END U/S FOR CONCRETE PIPE $H_L = 0.2 \frac{V^2}{2g}$

(c) CONTRACTION (K_c)

$\frac{D_2}{D_1}$	K_c
0	0.5
0.4	0.4
0.6	0.3
0.8	0.1
1.0	0

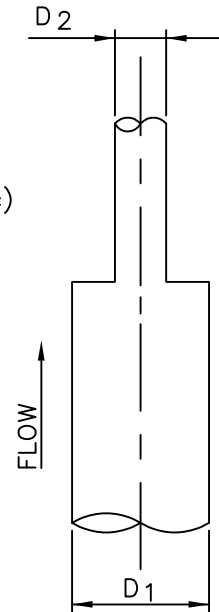

STORM PIPE ENERGY LOSS COEFFICIENT

TABLE 6-2

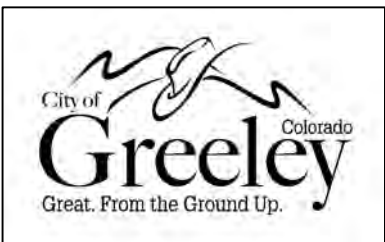

BENDS

CASE 1 CONDUIT ON 90° CURVES

$$K_b = 0.25 \frac{\theta}{\sqrt{90}}$$

NOTE: HEAD LOSS APPLIED AT P.C. FOR LENGTH

θ	K_b
90	0.25
60	0.20
45	0.18
30	0.14

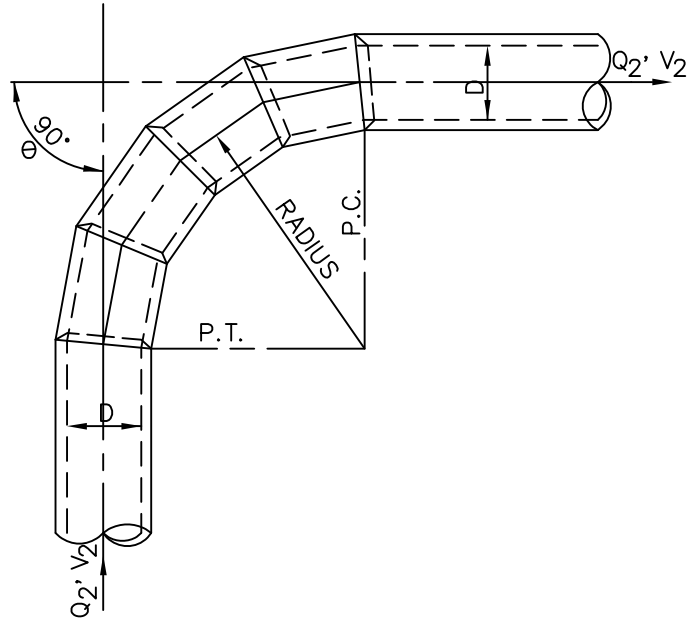

CASE II BENDS WHERE RADIUS IS EQUAL TO DIAMETER OF PIPE

NOTE: HEAD LOSS APPLIED AT BEGINNING OF BEND

θ BEND	K_b
90	0.50
60	0.43
45	0.35
22 1/2	0.20

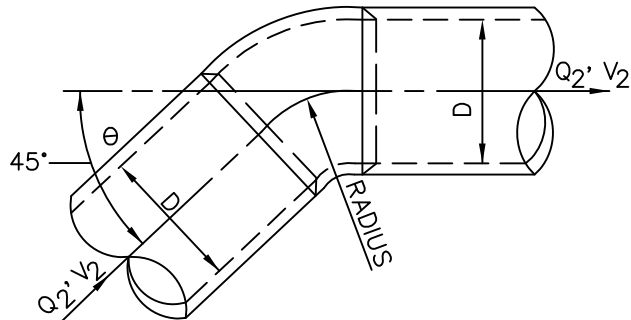

REFERENCE: APWA SPECIAL REPORT NO. 49, 1981

STORM PIPE ENERGY LOSS COEFFICIENT

TABLE 6-3

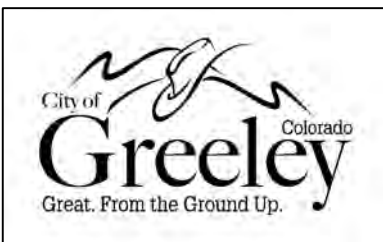

BENDS AT MANHOLES

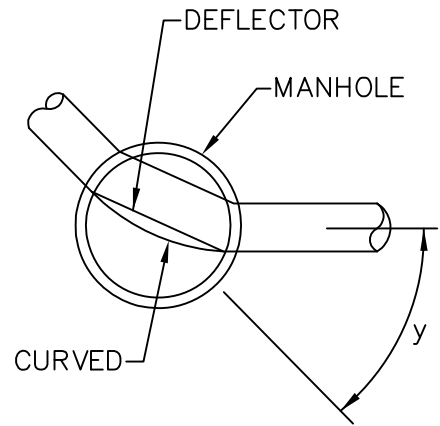
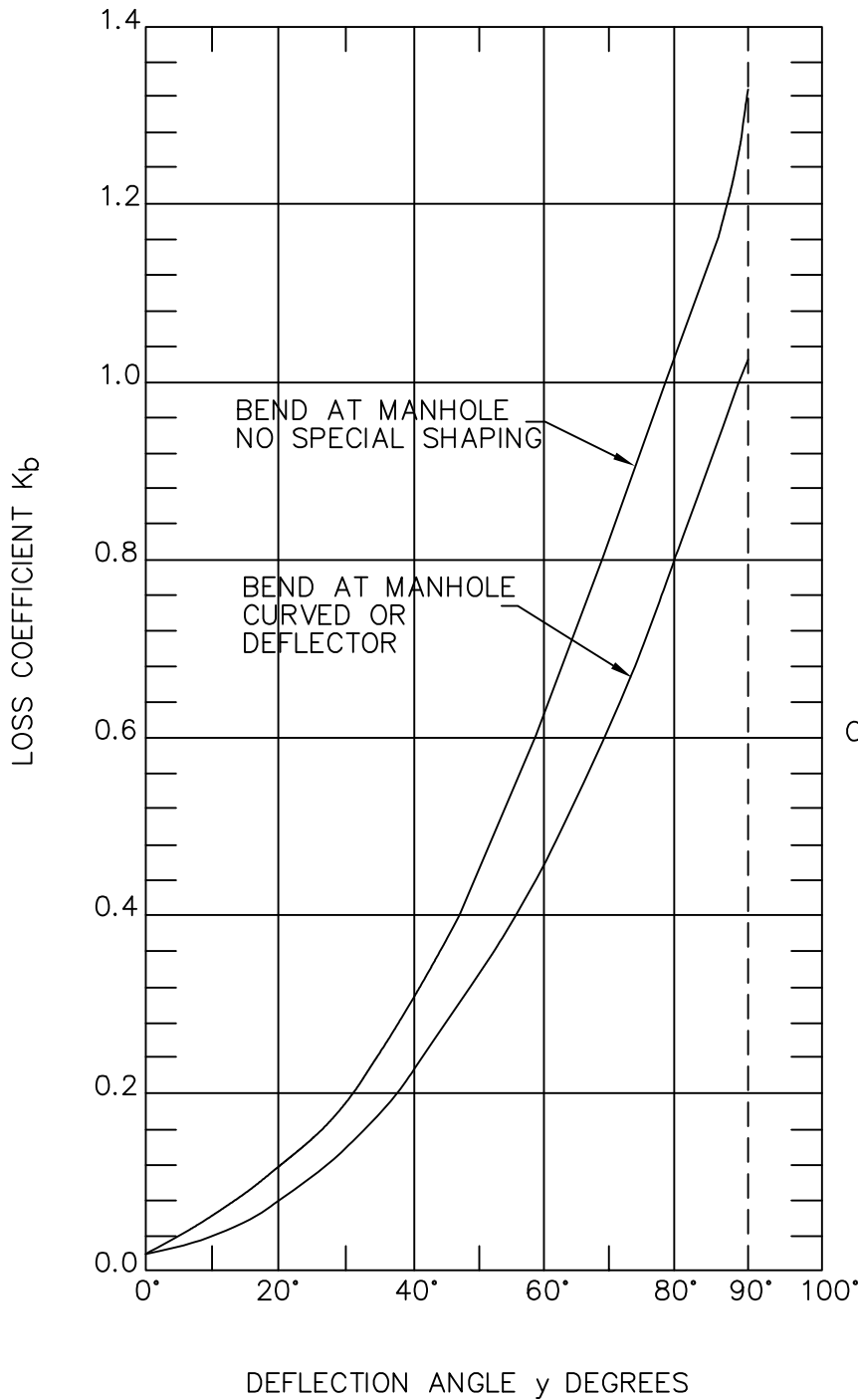

NOTE: HEAD LOSS APPLIED AT OUTLET OF MANHOLE

STORM PIPE ENERGY LOSS COEFFICIENT

TABLE 6-4

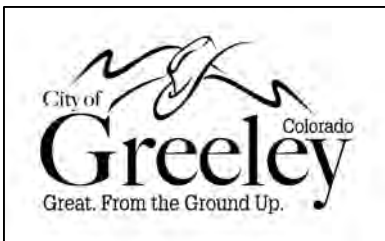

PUBLIC WORKS DEPARTMENT
 STORMWATER MANAGEMENT DIVISION
 1001 NINTH AVENUE GREELEY, COLORADO 80631

SCALE: NTS
 REVISED MARCH 2007

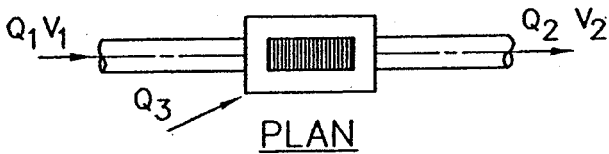

USE EQUATION 6.1
 $K_j = 0.05$

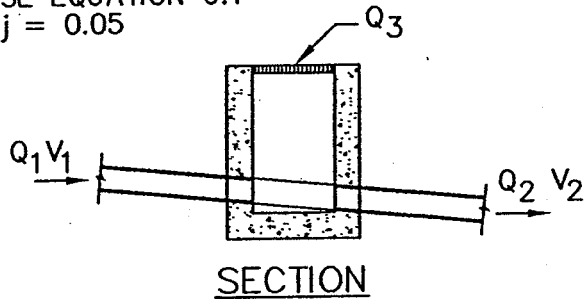

CASE I
 INLET OR STRAIGHT THROUGH
 MANHOLE ON MAIN LINE

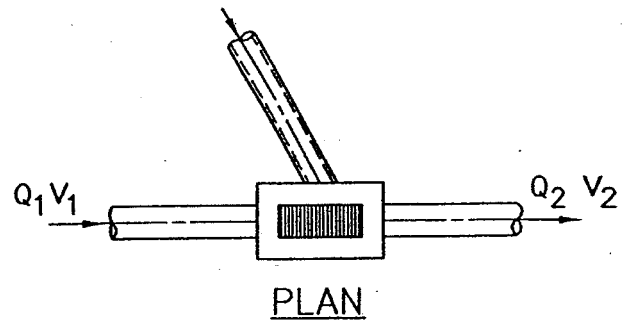

USE EQUATION 6.5
 $K_j = 0.25$

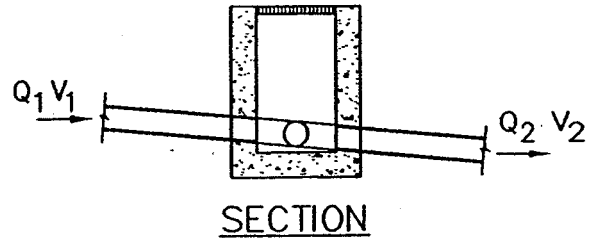

CASE II
 INLET ON MAIN LINE
 WITH BRANCH LATERAL

CASE III

θ°	K_j
22 1/2	0.75
45	0.50
60	0.35
90	0.25
NO LATERAL	SEE CASE I

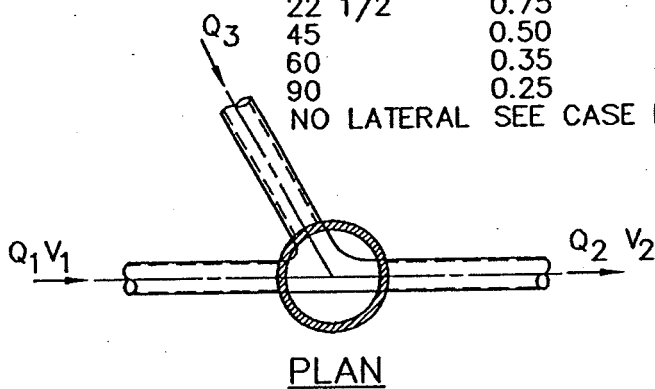

USE EQUATION 6.5

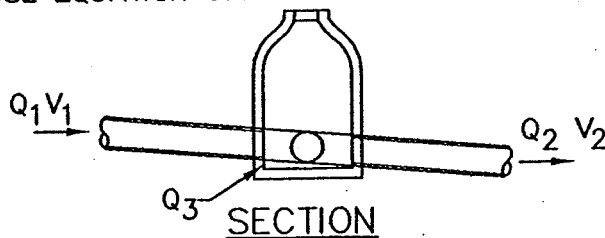

CASE III
 MANHOLE ON MAIN LINE
 WITH θ BRANCH LATERAL

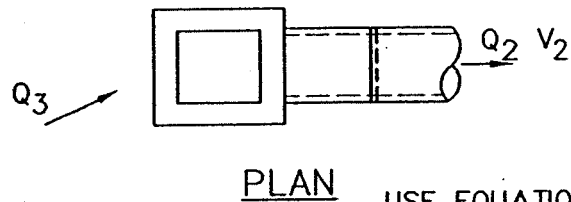

PLAN

USE EQUATION 6.1
 $K_j = 1.25$

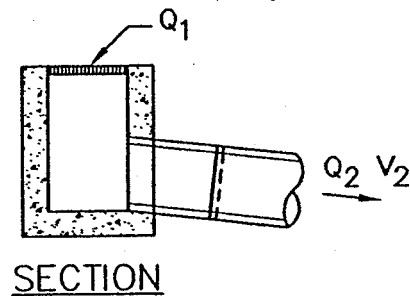

CASE IV
 INLET OR MANHOLE AT
 BEGINNING OF LINE

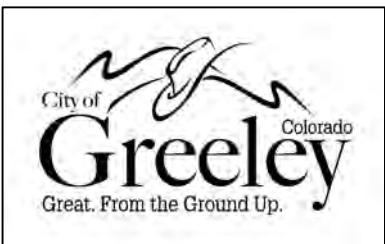

DESIGN EXAMPLE FOR STORM DRAINS

TABLE 6-6

1	2	3	4	5	6	7	8	9	10	11	12	13	14	15	16	17	18	19	20
STA	INVERT	D	W.S.	PIPE SHAPE	A	φ	V	Q	Hv	E.G.	Sf	AVG Sf	L	Hf	Hb	Hj	Hm	Ht	TOTAL LOSS
0+00	94.50	66	100.00	RND	23.76	0.00492	6.1	145	0.58	100.58	0.0019	0.0019	110	0.21	-	-	-	-	0.21
1+10	94.71	66	100.21	RND	23.76	0.00492	6.1	145	0.58	100.79	0.0019	0.0019	42.4	0.08	0.12	-	-	-	0.20
1+52.4	94.91	66	100.41	RND	23.76	0.00492	6.1	145	0.58	100.99	0.0019	0.0019	95.6	0.18	-	-	-	-	0.18
2+48	95.08	66	100.59	RND	23.76	0.00492	6.1	145	0.58	101.17	0.0019	0.0019	7.5	0.01	-	-	0.15	-	0.16
2+55.5	96.08	54	100.04	RND	15.90	0.00492	9.1	145	1.29	101.33	0.0054	0.0037	100	0.37	-	-	-	-	0.37
3+55.5	96.90	54	100.41	RND	15.90	0.00492	9.1	145	1.29	101.70	0.0054	0.0054	100	0.54	-	-	0.06	-	0.61
4+55.5	97.66	54	101.01	RND	15.90	0.00492	9.1	145	1.29	102.30	0.0054	0.0054	10	0.05	-	0.64	-	-	0.69
4+65.5	98.40	48	102.01	RND	12.57	0.00492	8.0	100	0.99	103.00	0.0049	0.0052	100	0.52	-	-	-	-	0.52
5+65.5	98.89	48	102.52	RND	12.57	0.00492	8.0	100	0.99	103.51	0.0049	0.0049	10	0.05	-	1.56	-	-	1.61
5+75.5	100.89	24	104.49	RND	3.14	0.00492	6.4	20	0.64	105.12	0.0079	0.0063	100	0.63	-	-	-	-	0.63
6+75.5	101.61	24	105.13	RND	3.14	0.00492	6.4	20	0.64	105.76	0.0079	0.0078							

$$Sf = \frac{\phi \cdot Hv}{R \cdot 1.33}$$

$$\phi = \frac{2g(n^2)}{2.21}$$

TOTAL FRICTION LOSS = 2.64
TOTAL FORM LOSS = 2.54

NOTE:
SEE FIGURE 6-4 AND 6-5

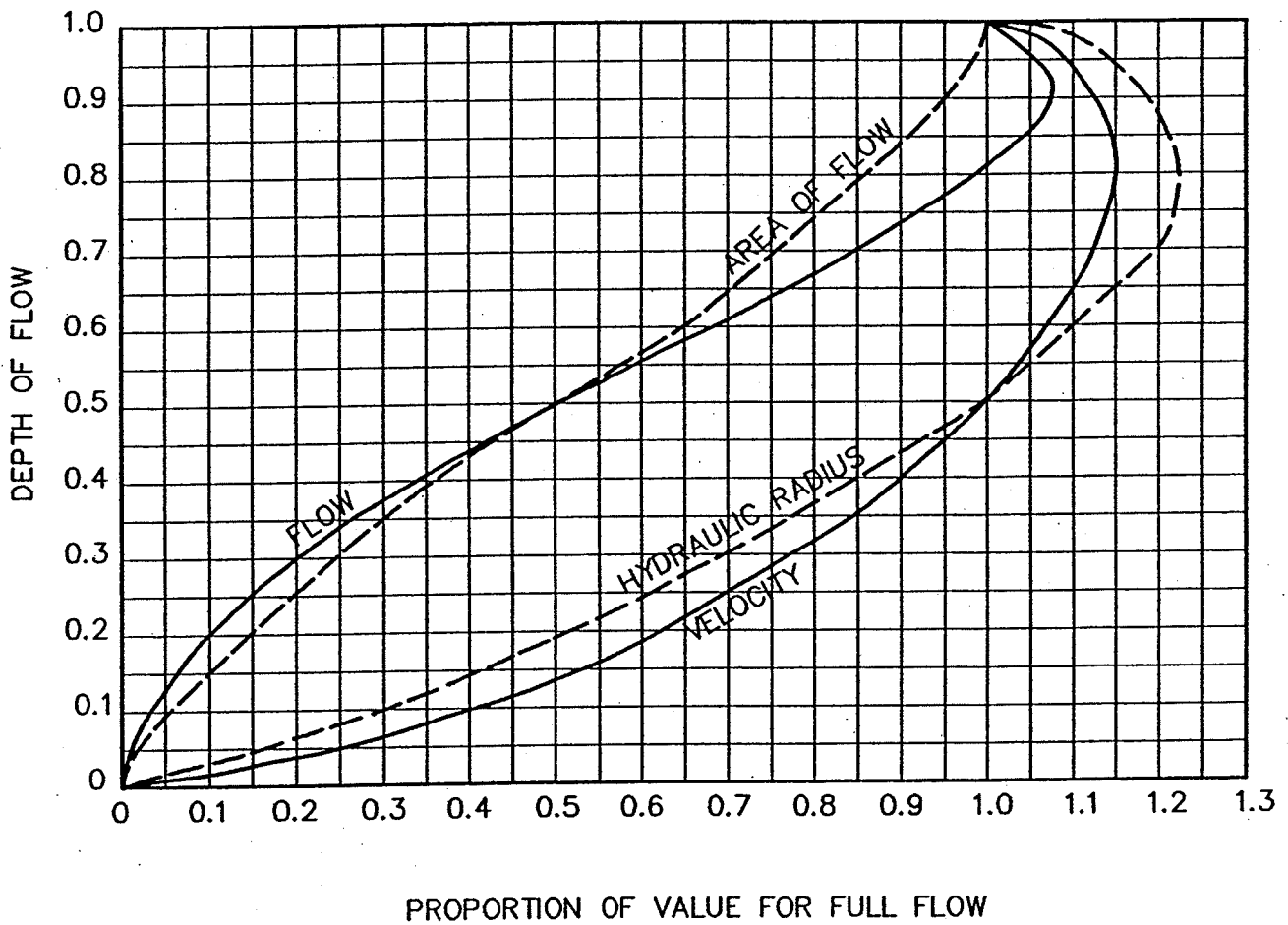

HYDRAULIC PROPERTIES CIRCULAR PIPE

FIGURE 6-1

PUBLIC WORKS DEPARTMENT
STORMWATER MANAGEMENT DIVISION
1001 NINTH AVENUE GREELEY, COLORADO 80631

SCALE: NTS
REVISED AUG 1996

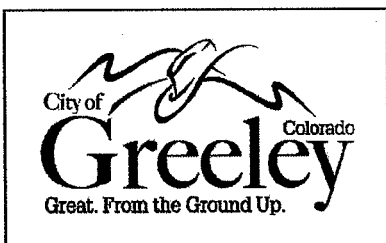

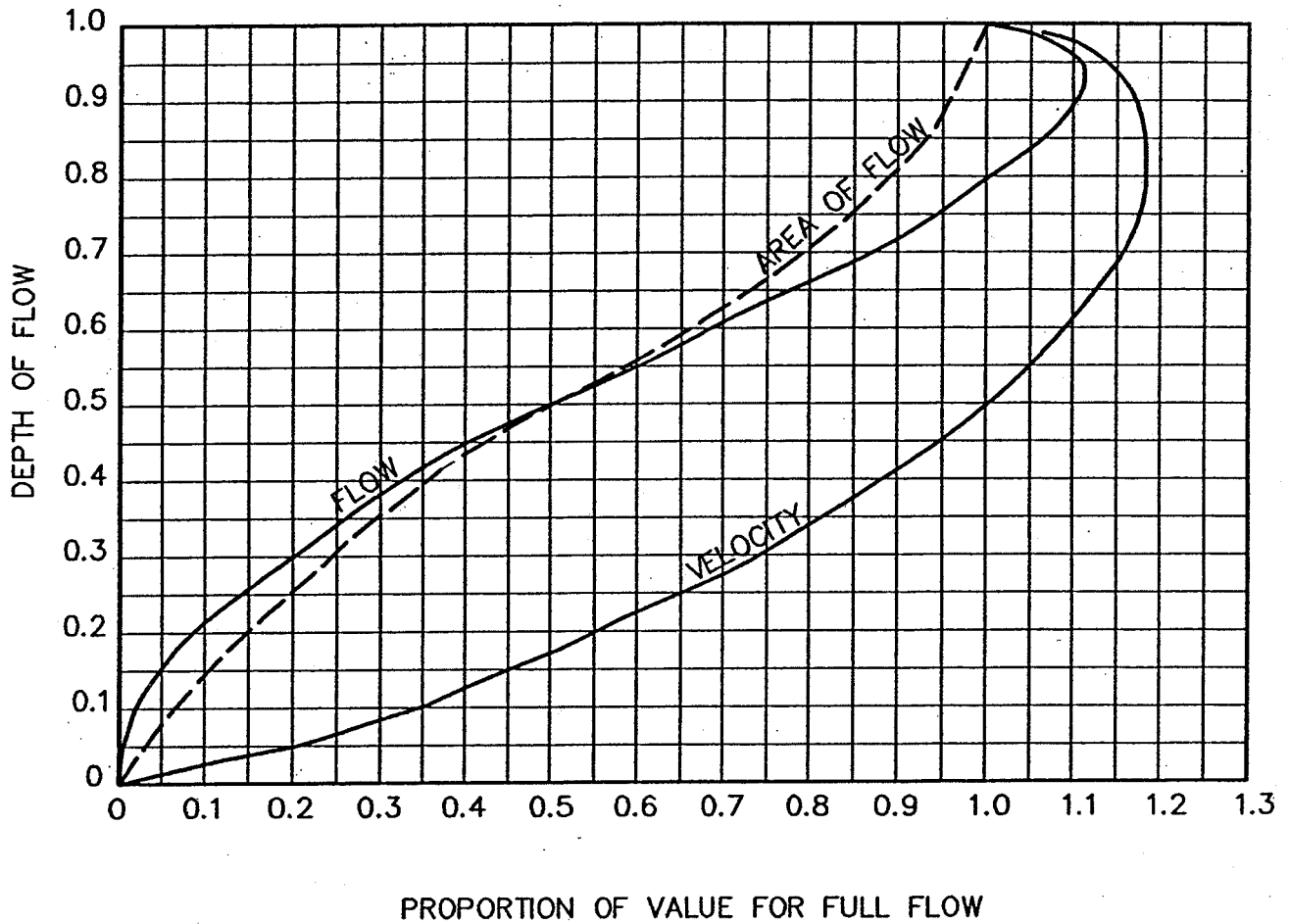

HYDRAULIC PROPERTIES HORIZONTAL ELLIPTICAL PIPE

PUBLIC WORKS DEPARTMENT
STORMWATER MANAGEMENT DIVISION
1001 NINTH AVENUE GREELEY, COLORADO 80631

FIGURE 6-2

SCALE: NTS
REVISED AUG 1996

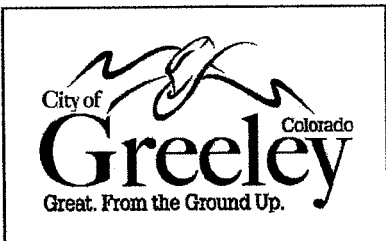

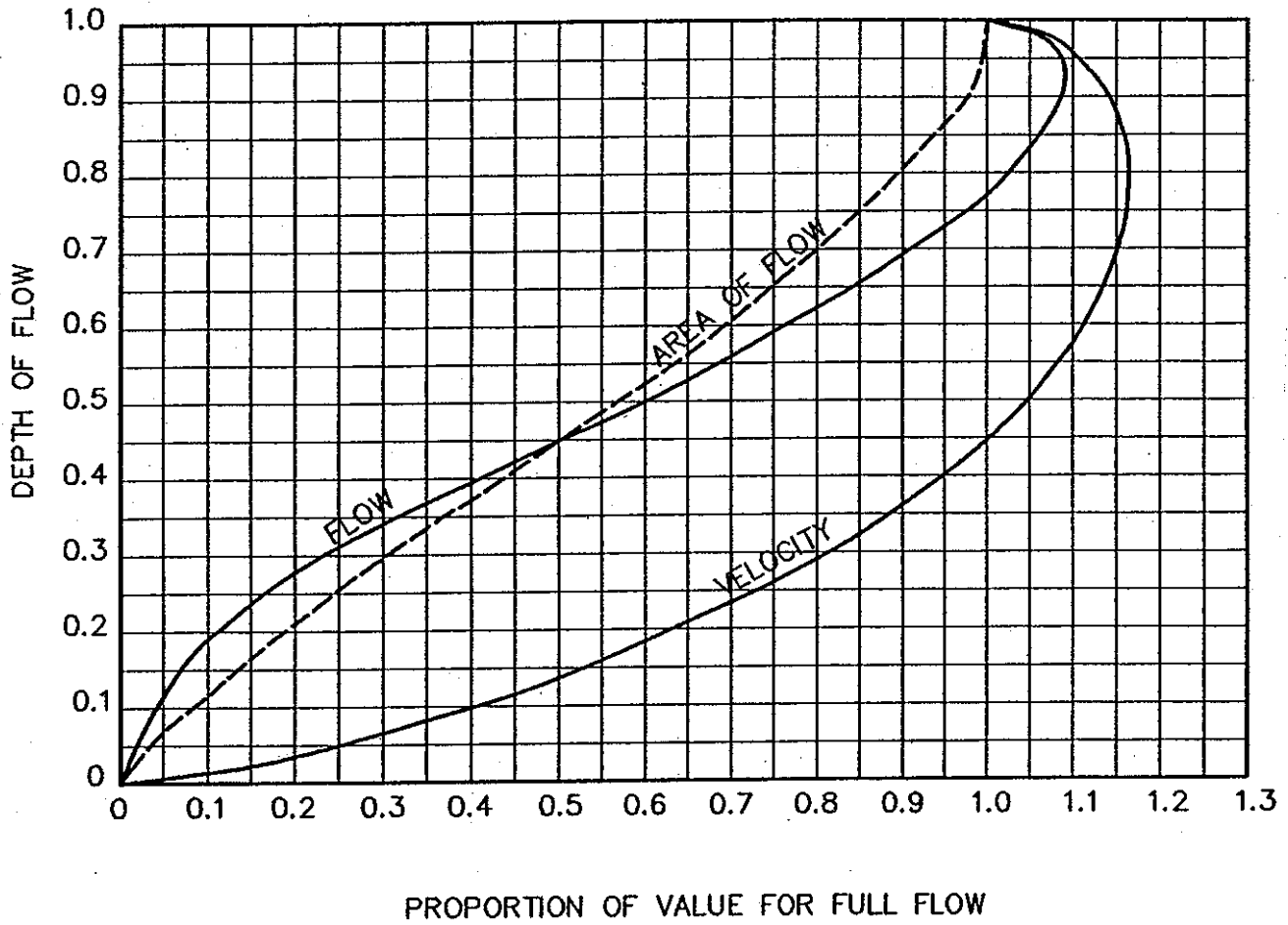

HYDRAULIC PROPERTIES ARCH PIPE

FIGURE 6-3

PUBLIC WORKS DEPARTMENT
STORMWATER MANAGEMENT DIVISION
1001 NINTH AVENUE GREELEY, COLORADO 80631

SCALE: NTS
REVISED AUG 1996

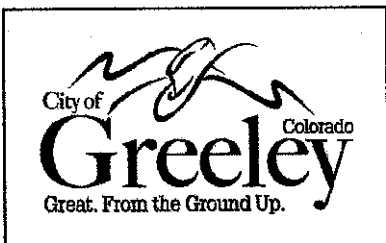

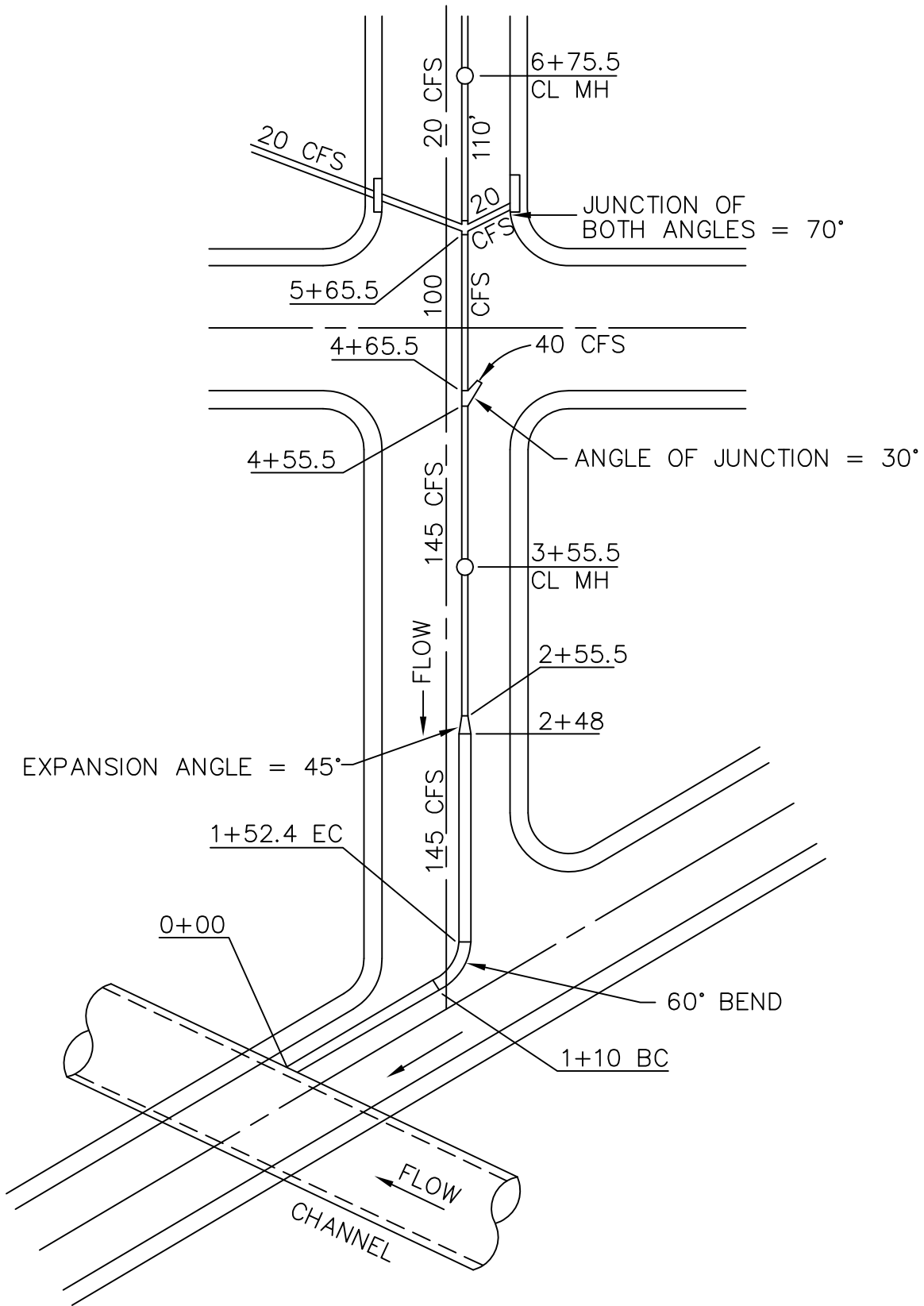

DESIGN EXAMPLE FOR STORM DRAINS - PLAN

FIGURE 6-4

PUBLIC WORKS DEPARTMENT
STORMWATER MANAGEMENT DIVISION
1001 NINTH AVENUE GREELEY, COLORADO 80631

SCALE: NTS
REVISED MARCH 2007

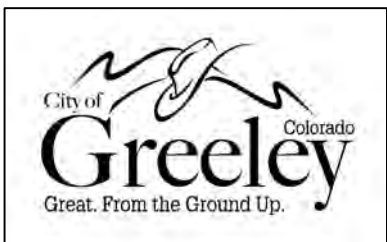

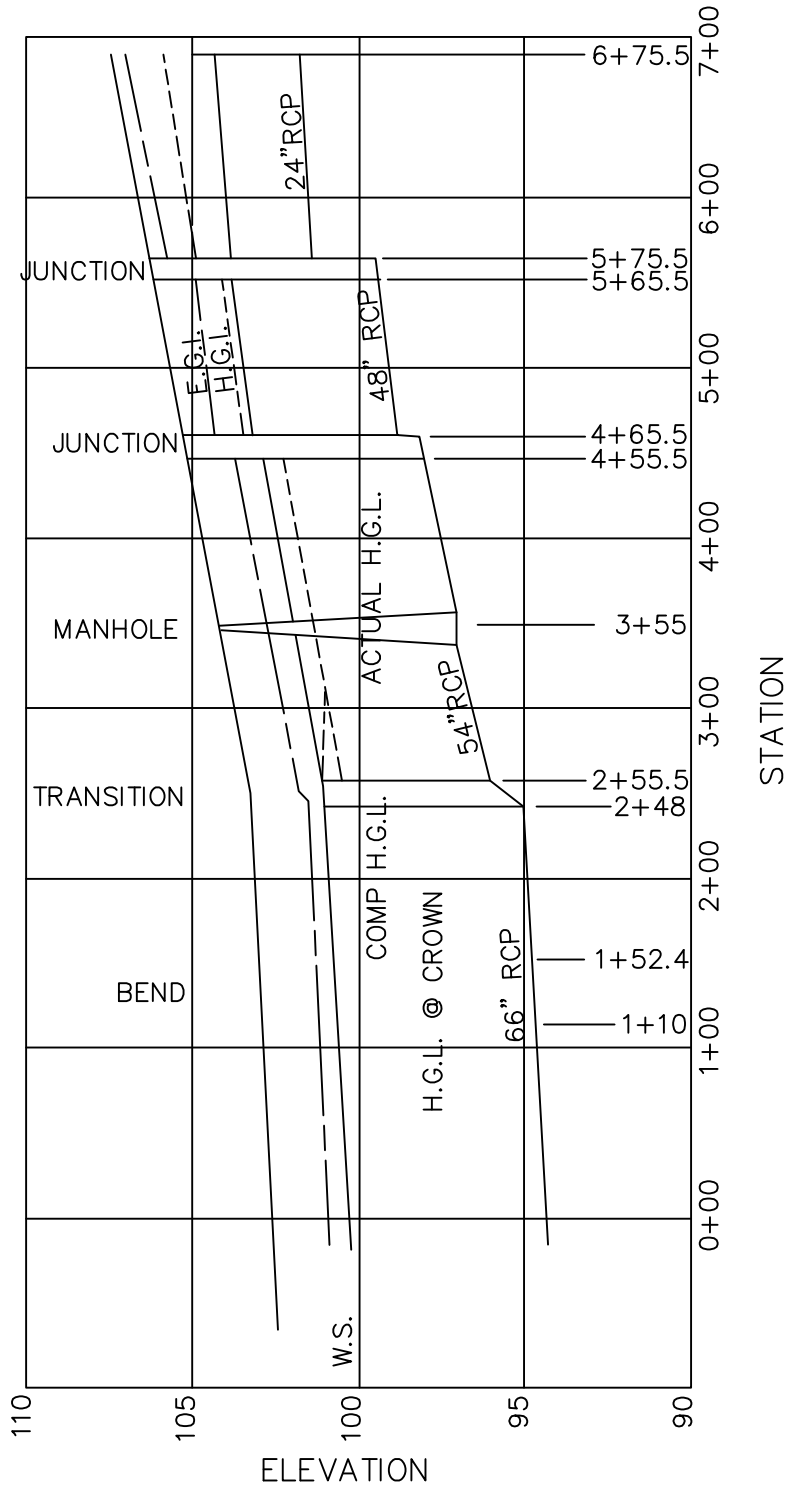

DESIGN EXAMPLE FOR STORM DRAINS - PROFILE

FIGURE 6-5

