

Addendum #1



Project Information

Project Name: Lead Service Line Replacements

Bid Number: F24-05-048

Date: June 25, 2024

Project Manager: Keri Fishlock

Addendum Purpose

The purpose of this addendum is to change the Schedule of Events. Specifically, the Inquiry Deadline and the Final Addendum dates. See attached revised RFP for the new schedule.



**CITY OF GREELEY
Purchasing**

**Request for Proposal
RFP #F24-05-048**

**WATER SERVICE LINE REPLACEMENTS –
PHASE 2 AND ADDITIONAL PHASES**

for

**CITY OF GREELEY
WATER & SEWER DEPARTMENT**

REQUEST FOR PROPOSAL (RFP)
RFP #F24-05-048

Procurement Contact: Alex Adame
Email Address: Purchasing@greeleygov.com
Telephone Number: 970-350-9325

Proposals must be received no later than the date indicated in the Schedule of Events below.

Proposals received after this date and time will not be considered for award.

ONLY ELECTRONIC RFP RESPONSES WILL BE ACCEPTED

Email your RFP Response to **purchasing@greeleygov.com**. Only emails sent to **purchasing@greeleygov.com** will be considered as responsive to the request for proposals. DO NOT submit your RFP Response to multiple email addresses. Emails sent to other City emails may be considered as non-responsive and may not be reviewed.

Proposals shall be submitted in a single Microsoft Word or PDF file under 20MB. The Proposal must not exceed 20 total pages, excluding cover letter, index or table of contents, front and back covers, and title pages/separation tabs. Pages shall be 8 ½ x 11 inch except for up to four (4) pages of 11 x 17 inches. Eleven-point font or larger must be used for the proposal and appendices. Resumes included as an appendix are not considered part of the 20 pages.

The RFP number and Project name must be noted in the subject line, otherwise the proposal may be considered as non-responsive to the RFP.

Electronic submittals will be held, un-opened, until the time and date noted in the RFP documents or posted addenda.

Schedule of Events (subject to change)	All Times are MST
RFP Issued	June 18 th 2024
Optional Pre-Proposal Conference 1001 11 th Ave, 2 nd Floor, Greeley 80631 & Virtual Via Microsoft Teams (See link below)	June 25 th 2024, 9:00AM 1001 11 th Ave, 2 nd Floor, Greeley 80631
Inquiry Deadline	July 3 rd 2024, 2:00 PM
Final Addendum Issued	July 8 th 2024
Proposal Due Date	July 19 th 2024, 2:00pm
Interviews (tentative)	TBD
Estimated Notice of Award	TBD

PREPROPOSAL CONFERENCE INVITE

Microsoft Teams [Need help?](#)

[Join the meeting now](#)

Meeting ID: 260 127 547 283

Passcode: GQdMZx

Dial in by phone

[+1 347-966-8471,,875985113#](#) United States, New York City

[Find a local number](#)

Phone conference ID: 875 985 113#

TABLE OF CONTENTS

Section	Title
I	Background, Overview & Goals
II	Statement of Work
III	Administrative Information
IV	Proposal Submission
V	Response Format
VI	Evaluation and Award

EXHIBITS

Exhibit	Title
1	Proposal Acknowledgement
2	Sample Contract
3	Insurance
4	Debarment Form
5	CO SRF Required Specifications
6	Davis Bacon Wages General Decision

ATTACHMENTS

ATCH	Title
A	Lead Protection Program Phasing Map
B-1	Potable Water Service Line Installation Drawing 1
B-2	Potable Water Service Line Installation Drawing 2
C	Water Service Connection – Tapping Saddle
D	Phase 02 Service Line Replacement Location Map (Draft)
E	COG Standards Section 3.08 Tapping
F	COG Streets Construction Spec

“Public Viewing Copy: The City is a governmental entity subject to the Colorado Open Records Act, C.R.S. §§ 24-72-200.1 et seq. (“CORA”). Any proposals submitted hereunder are subject to public disclosure by the City pursuant to CORA and City ordinances. Vendors may submit one (1) additional complete proposal clearly marked “FOR PUBLIC VIEWING.” In this version of the proposal, the Vendor may redact text and/or data that it deems confidential or proprietary pursuant to CORA. Such statement does not necessarily exempt such documentation from public disclosure if required by CORA, by order of a court of appropriate jurisdiction, or other applicable law. Generally, under CORA trade secrets, confidential commercial and financial data information is not required to be disclosed by the City. Proposals may not be marked “Confidential” or ‘Proprietary’ in their entirety. All provisions of any contract resulting from this request for proposal will be public information.”

SECTION I. BACKGROUND, OVERVIEW, AND GOALS

A. Background

The City of Greeley is a home rule municipality with a council-manager form of government and is the county seat and the most populous municipality of Weld County, Colorado. Greeley is in northern Colorado and is situated 52 miles north-northeast of the Colorado State Capitol in Denver. According to the U.S. Census Bureau, the population of the city is roughly 111,000 which makes it the 12th-most populous city in Colorado. The City has an annual budget of ~\$490M with a fiscal year that starts Jan 1st, and employees over 1100 employees. Greeley is a major city of the Front Range Urban Corridor and home to the University of Northern Colorado which is a public baccalaureate and graduate research university with approximately 12,000 students and six colleges as well as Aims Community College, which has served the community since 1967.

B. Overview

This project anticipates funding from the Colorado State Revolving Fund (SRF) loan program. Bidder's attention is called to the SRF requirements in the bid package. Disadvantaged Business Enterprise (DBE) requirements and goals are included. Also, certified DBEs or a consortium of certified DBEs are encouraged to bid.

The City of Greeley Water & Sewer Department supplies water to its customers through approximately 29,000 residential, commercial, and industrial service lines (services). The ownership of these service lines is split at the property line, or "curb stop", between the City of Greeley and the property owner. The City of Greeley maintains records of size and material for the public owned portion of the service line but has very limited information for the private owned portion.

In December of 2021, the Environmental Protection Agency (EPA) released revisions to the Lead and Copper Rule (LCRR) that strengthen the regulatory framework governing lead in drinking water. One of the key elements of the LCRR is the requirement for water systems to develop and maintain a service line inventory, including material information for both the publicly and privately owned portions of service lines within our system. If the material of the service line identified is determined to be lead, undeterminable, or galvanized steel requiring replacement, the service line will require replacement. The potable water mains are typically buried four to eight feet deep, and services lines are typically in the same range to stay below frost depths.

The City of Greeley is performing an inventory of all water service lines, utilizing the following methods:

- Desktop Record Review
- Mechanical Excavation (Potholing)
- Visual Service Line Inspections

The City of Greeley plans to approach the inventory and replacements in 5 separate phases. **Attachment A** of this RFP details the location and schedule for these phases. Phase 01 Replacements have been completed as part of a previous contract. Phase 02 replacements are planned to start August 2024 and be completed by December 2024. **Attachment D** of this RFP provides a map showing the location of properties currently scheduled for replacement in Phase 02. Phase 02 may be awarded to a single contractor or multiple contractors. It includes approximately:

- 133 private side replacements
- 7 public side replacements
- 1 full replacement

The purpose of this RFP is to source contractors to replace the water service lines that are made of lead, unknown material, or galvanized steel requiring replacement that we have identified through our ongoing inventory effort. This RFP will replace previous **RFP #F22-11-098**, with the purpose of meeting Colorado State Revolving Fund (SRF) loan requirements for our Phase 02 replacements and future phases (In 2024, the City of Greeley was awarded an SRF loan to assist with the lead inventory and replacement program). **Exhibit 5, Colorado State Revolving Fund Required Specifications** details the requirements that shall be adhered to by all contractors proposing to the RFP. The requirements include the following sections:

- Section 1: Davis-Bacon Prevailing Wage Requirements
- Section 2: American Iron and Steel
- Section 3: National Term on Suspension and Debarment
- Section 4: Equal Employment Opportunity
- Section 5: Williams-Steiger Occupational Safety and Health Act of 1970
- Section 6: Discovery of Archaeological and Other Historical Items
- Section 7: Disadvantaged Business Enterprise (DBE) – SRF Program Grant Agreement Information and Requirements
- Section 8: Prohibition on Certain Telecommunication and Video Surveillance Services or Equipment
- Section 9: Signage Requirements
- Section 10: Build America, Buy America (BABA)

The total quantity of remaining water service lines that must be replaced is currently unknown but is not expected to exceed 1,500. The contractor shall perform both full and partial service line replacements at multiple sites, as directed by the City of Greeley. The desired end state following a City of Greeley directed replacement of a water service line is that there is no remaining lead, unknown material, or galvanized steel requiring replacement, anywhere in the service line between the water main and the first fitting within the dwelling. The contractor shall provide all personnel, equipment, restoration, permitting, traffic control, and vehicles necessary to sufficiently perform the work. Coordination with the City or its representative is essential for replacing water service lines made of lead, unknown material, and galvanized steel requiring replacement.

The overarching purpose of this RFP is to establish contracts for our Phase 02 Replacements and form a multi-year partnership and pricing for full and partial service line replacements from at least two (2) experienced contractors. The qualified contractors will become an integral part of Greeley water service line replacement project. The number of replacements will vary from year to year and will be at the discretion of the City of Greeley. The work may be modified to meet any changes in the overall project to meet EPA/CDPHE regulations.

Contractors not selected for Phase 02 Replacement but otherwise qualified will be retained and given the opportunity to bid on future phases of the project. All qualified contractors will be notified that they have been selected as pre-qualified contractors and given the opportunity to bid on each subsequent replacement phase.

C. Goals

The project goal is to effectively and efficiently replace all identified service lines made of lead, unknown material, or galvanized steel requiring replacement, as identified by the City of Greeley, with new service lines made of copper crosslinked PEX, Q-Line or other material meeting Water & Sewer Construction specifications. This project will be completed through multiple construction contract awards to pre-qualified contractors until the project is finished in December 2026. Future replacements will be determined based on the results of the WATER SERVICE LINE INVENTORY POTHOLING PROJECT.

SECTION II. STATEMENT OF WORK

A. Scope of Services

The proposer shall identify a project manager that will have oversight of the project on the contractor side and will coordinate with City of Greeley staff and/or representative and other contractors who may be completing any mechanical excavation in support of water service line material identification or other work tasks related to the City of Greeley’s larger Lead Service Line Inventory and Replacement Program. In general, the qualified Contractors through this WATER SERVICE LINE REPLACEMENT PROJECT Contracting arrangement will become an integral part of the City of Greeley’s team to deliver work in support of the larger Lead Service Line Inventory and Replacement Program.

Pre-selected qualified contractors will be provided with a scope that includes a list of addresses and the type of service line replacement required and given the opportunity to bid on each replacement phase. The replacement types are:

- **Private-side partial service line replacement** is defined as replacing the customer owned portion of the service line, which is typically from the water meter to the first fitting in the dwelling.
- **Public-side partial service line replacement** is defined as replacing the city owned portion of the service line, which is typically from the water main to the curb stop.
- **Full-service line replacement** is defined as replacing the entire service line, from the water main to the first fitting within the dwelling.

The City of Greeley's standard drawing of a potable water service line, stop box, and outside meter installation has been attached to this RFP as **Attachment B-1 and B-2**. The full-service line replacements will require new taps on the mains which shall be installed per City of Greeley Construction Specifications and Standard drawings latest version as shown in **Attachment C**.

Additionally, the following services may be required:

- New installation or replacement of an existing meter pit, or meter-setter
- Installation of new curb stop valve and box
- Modification of internal plumbing connections inside the residential dwelling (home), commercial business, or apartment complex.
- Replacement of the connector pipe between the curb stop and meter pit if it is lead or galvanized steel.

Contractors may use methods including open trench excavation, trenchless boring machines, and other trenchless methods. At some properties contractors will be required to use trenchless and directional drilling (boring). Trenched installations will be allowed only when deemed favorable by the City of Greeley, or their representative based on the site conditions at a specific property.

The contractor is required to restore disturbed property areas back to the condition they were found in (not as new). Specifically, this includes:

- Reinstatement of grading and landscaping including turf, gravel, and flowerbeds
- Replacing asphalt and concrete surfaces etc.
- Repair irrigation systems damaged in the process.

Where it is anticipated that major disturbance will be caused to plants, shrubs, trees or other facilities the Contractor shall consult with the City of Greeley. The City will hold a contingency fund for addressing these on a case-by-case basis.

Once a Work Contract is issued, the contractor will mobilize to the geographic area specified and replace all listed water services as detailed in the scope of work. Following the receipt of the Work Contract, the contractor will become the primary agent to communicate with the Customer receiving the water service line replacement. The contractor shall be responsible for all notifications and updates to the Customer through to restoration. The City of Greeley will attempt to organize service locations in need of replacement by geographical area, intentionally trying to group replacements in the same residential block / commercial block / neighborhood into the same Work Contract.

The Contractor shall provide a 2-year warranty on all work performed as described in the attached contract. The Contractor shall aide the City of Greeley in answering Customer Requests for Information (RFI) throughout the project and if required during the 2-year warranty period.

Contractors shall provide two bid pricing schedules to price the anticipated work outlined in the RFP. Bid Schedule A lists specific properties requiring replacement in Phase 02. Bid Schedule B lists standard pricing and miscellaneous installation costs that could be encountered through the contract.

The Contractor shall submit fixed rates for any support that maybe utilized for construction of the projects for the term of this contract. The fixed rates established in the initial contract allows for annual price increase or decrease adjustments in subsequent years. The proposed amount of increase or decrease in fixed rates shall be based on the justifications for the change and shall not exceed the ENR Construction Cost Index for Denver Colorado. The

new proposed rates must be approved by the City in advance of being used in project costs. Contractor shall include pricing for each bid schedule as shown below and include equipment and labor rates for additional services that may be required within the contracted period.

Additional Notes on Scope

- The contractor shall include in their private-side and full replacement costs a site visit with the homeowner prior to the replacement to check site specific conditions, communicate the work plan and provide City of Greeley information materials. The City of Greeley Representative shall be invited to these site visits, and will attend at their discretion.
- During the site visit, the contractor will check the material of the water service line as it enters the basement to confirm that the replacement is required, if the material differs from what is documented, the contractor shall notify the City of Greeley Project Manager or representative immediately. Deviations to the standard work plan and any additional expense beyond the bid price should be communicated to the City of Greeley Project Manager or representative for approval prior to work.
- Where possible, excavations for replacements should be started in soft-scape areas rather than asphalt or concrete surfaces. This approach minimizes unnecessary damages to hard surfaces if a service line was mis-identified during the WATER SERVICE LINE INVENTORY POTHOLING PROJECT, and the replacement requires aborting.
- During replacements the contractor shall check the material of the connector pipe located between the curbstop and the meter pit. The length of this connector is generally 3 feet or less. If the connector is found to be lead or galvanized steel, it shall also be replaced at the unit price.
- The contractor will supply the saddles and tapping materials for all taps. The contractor shall perform all wet taps on mains 16" and smaller diameter under the direct supervision of the City. City will perform taps on mains 20" and larger. Refer to City of Greeley Potable Water Distribution System Design Criteria Section 3 - paragraph 3.08. PVC pipes are required to be de-energized prior to tapping, with assistance from the City.
- Existing corps on the main line are not to be re-used but must be replaced due to the potential for them to contain lead materials. The new corp may utilize the existing hole where feasible. If the service line needs relocating along the main line, the existing hole shall be sealed with a saddle repair clamp, and a new tapping saddle be installed at the new location.
- For full replacements and public side replacements, the main water line must be de-energized. The City of Greeley staff shall assist in de-energizing the main water line in coordination with the contractor. The contractor shall notify effected residents 24 hours before shutdowns.
- Meters are owned by the City of Greeley. City will provide a new E-Series Badger meter to replace any mechanical meters. Contractor shall replace the meter with the service line replacement. If meters are located inside the house or in the back yard, meters will be relocated to ROW line or tree lawn to meet Greeley standards if feasible. If performing a full service-line replacement, the alignment may be adjusted to meet City of Greeley standards and to reduce conflicts, contractor to coordinate with City on final alignment.
- Work hours 7AM-5PM, Monday to Friday excluding City of Greeley holidays.
- Tracer wire will be required for all water service line replacements to meet 2018 Subsurface Utility Engineering (SUE) law requirements and City of Greeley standards, see attached drawings, final details in Greeley Construction Specifications and standard details.
- The Contractor is responsible for compaction testing of backfill within the ROW, testing is not required if Flowfill is used. Please refer to the City of Greeley Design Criteria & Construction Specifications - STREETS VOLUME 1 for details.
- The contractor should include within their bid the proposed methods for penetrating the basement wall. Where the foundation is exposed, visual inspection and photos of foundations are to be taken by the contractor prior to work commencing and after the work is complete. The contractor shall immediately notify the City of any foundations that are deemed to be in poor condition or otherwise at risk of damage during construction. If we receive this notice prior to construction, the City will work with the contractor to determine

the best approach to completing service line replacement and the City Contingency fund can be utilized for remediation costs.

- The contractor is responsible to install a watertight seal around the new service line entering the home. The seal shall be on both sides of the wall. The homeowner is responsible for all repairs to interior finishing. The existing service line penetration or abandoned service line shall also be installed with a watertight seal.
- The contractor shall leave clean/smooth edges to any interior finishes and is responsible for cleaning all debris.
- A licensed plumber will be required to make the connections inside the houses per building department requirements. City of Greeley Building Inspection will inspect the new connection within the homeowners property. Contractor is required to get a service line replacement permit with the building department for each location completed. There will be no fee for these permits.
- The contractor is responsible to apply for Right of Way Permits and Building Permits. The City will cover the permit fees.

Phase 02 Specific Notes on Scope

- The list of properties in the Phase 02 Bid Schedule below is subject to change. Properties may be added or removed from the list by the City. The City must receive written consent from the property owner prior to replacement of the private-side service line. Properties without consent will be removed from the consent list or postponed.
- Phase 02 may be awarded to one contractor or divided between multiple contractors.
- The bid price for each property on Schedule A should be inclusive of all anticipated costs including:
 - Site visit and walk through with the homeowner prior to construction.
 - Locates and any potholing required.
 - Traffic Control Costs (based on replacements in the same street being completed together)
 - Temporary removal and replacement of fence sections, bushes or plants to allow completion of work.
 - Restoration of existing landscaping back to the current condition.
 - Replacement of concrete/asphalt sections
 - Repair of irrigation lines
 - New plumbing connection within property to existing first fitting.
- For pricing purposes assume the existing service line enters the property mid-way along either the left hand-side or right hand-side of the property via a basement or crawlspace. The new service line may take a more efficient route from the water meter to the property but will need a suitable connection point into the household plumbing.
- Prices may be adjusted after the home walkthrough to reflect actual conditions. Any increase shall need approval by City of Greeley Project Manager or their representative. If an alternate construction technique is preferable due to site conditions the replacement may be transferred to an alternate contractor.
- The bid schedule includes a \$100,000 contingency line item. This is to provide additional compensation for unanticipated costs that might include the replacement of meter pits, curbstops, connector replacement or other unforeseen construction issues. The contingency funds are to be used only with the approval of COG Project Manager or designated representative.

Bid Schedules

WATER SERVICE LINE REPLACEMENT PROJECT RFP					
Item No.	Work & Material	Details	Unit of Measure	Unit Price	Total Amount
SCHEDULE A - PHASE 02 BID SCHEDULE					
A-1	Work Order Mobilization / Demobilization, Bonds, and Insurance		LS		\$0
A-2	Contingency Fund (used only with prior approval by COG Project Manager)		LS	100000	\$100,000
A-3	FULL REPLACEMENT	407 11TH AVE	LS		\$0
A-4	PUBLIC REPLACEMENT	1607 10TH AVE	LS		\$0
A-5	PUBLIC REPLACEMENT	606 12TH ST	LS		\$0
A-6	PUBLIC REPLACEMENT	310 12TH AVE	LS		\$0
A-7	PUBLIC REPLACEMENT	1129 4TH ST	LS		\$0
A-8	PUBLIC REPLACEMENT	1030 7TH AVE	LS		\$0
A-9	PUBLIC REPLACEMENT	1209 7TH AVE	LS		\$0
A-10	PRIVATE-SIDE REPLACEMENT	530 12TH ST	LS		\$0
A-11	PRIVATE-SIDE REPLACEMENT	728 12TH ST	LS		\$0
A-12	PRIVATE-SIDE REPLACEMENT	918 8TH AVE	LS		\$0
A-13	PRIVATE-SIDE REPLACEMENT	800 9TH ST	LS		\$0
A-14	PRIVATE-SIDE REPLACEMENT	221 10TH ST	LS		\$0
A-15	PRIVATE-SIDE REPLACEMENT	531 7TH ST	LS		\$0
A-16	PRIVATE-SIDE REPLACEMENT	1015 5TH ST	LS		\$0
A-17	PRIVATE-SIDE REPLACEMENT	2209 9TH ST	LS		\$0
A-18	PRIVATE-SIDE REPLACEMENT	1501 9TH ST	LS		\$0
A-19	PRIVATE-SIDE REPLACEMENT	1317 9TH ST	LS		\$0
A-20	PRIVATE-SIDE REPLACEMENT	1301 9TH ST	LS		\$0
A-21	PRIVATE-SIDE REPLACEMENT	1213 9TH ST	LS		\$0
A-22	PRIVATE-SIDE REPLACEMENT	1115 9TH ST	LS		\$0
A-23	PRIVATE-SIDE REPLACEMENT	1107 9TH ST	LS		\$0
A-24	PRIVATE-SIDE REPLACEMENT	1019 9TH ST	LS		\$0
A-25	PRIVATE-SIDE REPLACEMENT	415 14TH AVE	LS		\$0
A-26	PRIVATE-SIDE REPLACEMENT	920 8TH AVE	LS		\$0
A-27	PRIVATE-SIDE REPLACEMENT	700 11TH ST	LS		\$0
A-28	PRIVATE-SIDE REPLACEMENT	1127 3RD ST	LS		\$0
A-29	PRIVATE-SIDE REPLACEMENT	221 11TH ST	LS		\$0
A-30	PRIVATE-SIDE REPLACEMENT	312 12TH ST	LS		\$0
A-31	PRIVATE-SIDE REPLACEMENT	1017 5TH ST	LS		\$0
A-32	PRIVATE-SIDE REPLACEMENT	1329 4TH ST	LS		\$0
A-33	PRIVATE-SIDE REPLACEMENT	401 14TH AVE	LS		\$0
A-34	PRIVATE-SIDE REPLACEMENT	1214 3RD ST	LS		\$0
A-35	PRIVATE-SIDE REPLACEMENT	412 N 11TH AVE	LS		\$0
A-36	PRIVATE-SIDE REPLACEMENT	406 N 11TH AVE	LS		\$0

A-37	PRIVATE-SIDE REPLACEMENT	412 11TH AVE	LS		\$0
A-38	PRIVATE-SIDE REPLACEMENT	409 12TH AVE	LS		\$0
A-39	PRIVATE-SIDE REPLACEMENT	317 10TH AVE	LS		\$0
A-40	PRIVATE-SIDE REPLACEMENT	306 13TH AVE	LS		\$0
A-41	PRIVATE-SIDE REPLACEMENT	412 13TH AVE	LS		\$0
A-42	PRIVATE-SIDE REPLACEMENT	301 12TH AVE	LS		\$0
A-43	PRIVATE-SIDE REPLACEMENT	318 1/2 12TH AVE	LS		\$0
A-44	PRIVATE-SIDE REPLACEMENT	318 12TH AVE	LS		\$0
A-45	PRIVATE-SIDE REPLACEMENT	320 13TH AVE	LS		\$0
A-46	PRIVATE-SIDE REPLACEMENT	315 12TH AVE	LS		\$0
A-47	PRIVATE-SIDE REPLACEMENT	408 9TH AVE	LS		\$0
A-48	PRIVATE-SIDE REPLACEMENT	309 9TH AVE	LS		\$0
A-49	PRIVATE-SIDE REPLACEMENT	102 N 9TH AVE	LS		\$0
A-50	PRIVATE-SIDE REPLACEMENT	312 9TH AVE	LS		\$0
A-51	PRIVATE-SIDE REPLACEMENT	935 C ST	LS		\$0
A-52	PRIVATE-SIDE REPLACEMENT	900 9TH AVE	LS		\$0
A-53	PRIVATE-SIDE REPLACEMENT	1403 2ND ST	LS		\$0
A-54	PRIVATE-SIDE REPLACEMENT	1301 2ND ST	LS		\$0
A-55	PRIVATE-SIDE REPLACEMENT	1218 5TH ST	LS		\$0
A-56	PRIVATE-SIDE REPLACEMENT	1229 2ND ST	LS		\$0
A-57	PRIVATE-SIDE REPLACEMENT	1110 5TH ST	LS		\$0
A-58	PRIVATE-SIDE REPLACEMENT	1118 5TH ST	LS		\$0
A-59	PRIVATE-SIDE REPLACEMENT	1122 5TH ST	LS		\$0
A-60	PRIVATE-SIDE REPLACEMENT	1211 5TH ST	LS		\$0
A-61	PRIVATE-SIDE REPLACEMENT	810 4TH ST	LS		\$0
A-62	PRIVATE-SIDE REPLACEMENT	502 13TH AVE	LS		\$0
A-63	PRIVATE-SIDE REPLACEMENT	503 13TH AVE	LS		\$0
A-64	PRIVATE-SIDE REPLACEMENT	1314 5TH ST	LS		\$0
A-65	PRIVATE-SIDE REPLACEMENT	1309 5TH ST	LS		\$0
A-66	PRIVATE-SIDE REPLACEMENT	431 13TH AVE	LS		\$0
A-67	PRIVATE-SIDE REPLACEMENT	1215 5TH ST	LS		\$0
A-68	PRIVATE-SIDE REPLACEMENT	429 12TH AVE	LS		\$0
A-69	PRIVATE-SIDE REPLACEMENT	1013 5TH ST	LS		\$0
A-70	PRIVATE-SIDE REPLACEMENT	919 5TH ST	LS		\$0
A-71	PRIVATE-SIDE REPLACEMENT	911 5TH ST	LS		\$0
A-72	PRIVATE-SIDE REPLACEMENT	817 5TH ST	LS		\$0
A-73	PRIVATE-SIDE REPLACEMENT	803 5TH ST	LS		\$0
A-74	PRIVATE-SIDE REPLACEMENT	1116 4TH ST	LS		\$0
A-75	PRIVATE-SIDE REPLACEMENT	1302 4TH ST	LS		\$0
A-76	PRIVATE-SIDE REPLACEMENT	1308 4TH ST	LS		\$0
A-77	PRIVATE-SIDE REPLACEMENT	1306 4TH ST	LS		\$0
A-78	PRIVATE-SIDE REPLACEMENT	1222 4TH ST	LS		\$0
A-79	PRIVATE-SIDE REPLACEMENT	1314 4TH ST	LS		\$0
A-80	PRIVATE-SIDE REPLACEMENT	1310 4TH ST	LS		\$0

A-81	PRIVATE-SIDE REPLACEMENT	1316 4TH ST	LS		\$0
A-82	PRIVATE-SIDE REPLACEMENT	1320 4TH ST	LS		\$0
A-83	PRIVATE-SIDE REPLACEMENT	1226 4TH ST	LS		\$0
A-84	PRIVATE-SIDE REPLACEMENT	1229 4TH ST	LS		\$0
A-85	PRIVATE-SIDE REPLACEMENT	1327 4TH ST	LS		\$0
A-86	PRIVATE-SIDE REPLACEMENT	1315 4TH ST	LS		\$0
A-87	PRIVATE-SIDE REPLACEMENT	1317 4TH ST	LS		\$0
A-88	PRIVATE-SIDE REPLACEMENT	1117 4TH ST	LS		\$0
A-89	PRIVATE-SIDE REPLACEMENT	1207 4TH ST	LS		\$0
A-90	PRIVATE-SIDE REPLACEMENT	1203 4TH ST	LS		\$0
A-91	PRIVATE-SIDE REPLACEMENT	909 16TH ST	LS		\$0
A-92	PRIVATE-SIDE REPLACEMENT	1011 16TH ST	LS		\$0
A-93	PRIVATE-SIDE REPLACEMENT	300 12TH ST	LS		\$0
A-94	PRIVATE-SIDE REPLACEMENT	320 8TH AVE	LS		\$0
A-95	PRIVATE-SIDE REPLACEMENT	1125 3RD ST	LS		\$0
A-96	PRIVATE-SIDE REPLACEMENT	626 5TH AVE	LS		\$0
A-97	PRIVATE-SIDE REPLACEMENT	215 12TH ST	LS		\$0
A-98	PRIVATE-SIDE REPLACEMENT	201 12TH ST	LS		\$0
A-99	PRIVATE-SIDE REPLACEMENT	1021 4TH ST	LS		\$0
A-100	PRIVATE-SIDE REPLACEMENT	809 4TH ST	LS		\$0
A-101	PRIVATE-SIDE REPLACEMENT	822 3RD ST	LS		\$0
A-102	PRIVATE-SIDE REPLACEMENT	1220 3RD ST	LS		\$0
A-103	PRIVATE-SIDE REPLACEMENT	701 5TH ST	LS		\$0
A-104	PRIVATE-SIDE REPLACEMENT	418 8TH AVE	LS		\$0
A-105	PRIVATE-SIDE REPLACEMENT	614 8TH AVE	LS		\$0
A-106	PRIVATE-SIDE REPLACEMENT	1014 8TH AVE	LS		\$0
A-107	PRIVATE-SIDE REPLACEMENT	1222 7TH AVE	LS		\$0
A-108	PRIVATE-SIDE REPLACEMENT	505 6TH ST	LS		\$0
A-109	PRIVATE-SIDE REPLACEMENT	1217 5TH AVE	LS		\$0
A-110	PRIVATE-SIDE REPLACEMENT	1213 5TH AVE	LS		\$0
A-111	PRIVATE-SIDE REPLACEMENT	1007 4TH AVE	LS		\$0
A-112	PRIVATE-SIDE REPLACEMENT	1117 4TH AVE	LS		\$0
A-113	PRIVATE-SIDE REPLACEMENT	902 4TH AVE	LS		\$0
A-114	PRIVATE-SIDE REPLACEMENT	1004 4TH AVE	LS		\$0
A-115	PRIVATE-SIDE REPLACEMENT	1213 4TH AVE	LS		\$0
A-116	PRIVATE-SIDE REPLACEMENT	1102 3RD AVE	LS		\$0
A-117	PRIVATE-SIDE REPLACEMENT	1219 4TH AVE	LS		\$0
A-118	PRIVATE-SIDE REPLACEMENT	1221 4TH AVE	LS		\$0
A-119	PRIVATE-SIDE REPLACEMENT	514 6TH ST	LS		\$0
A-120	PRIVATE-SIDE REPLACEMENT	1122 3RD AVE	LS		\$0
A-121	PRIVATE-SIDE REPLACEMENT	1028 2ND AVE	LS		\$0
A-122	PRIVATE-SIDE REPLACEMENT	400 6TH ST	LS		\$0
A-123	PRIVATE-SIDE REPLACEMENT	409 6TH ST	LS		\$0
A-124	PRIVATE-SIDE REPLACEMENT	715 7TH ST	LS		\$0
A-125	PRIVATE-SIDE REPLACEMENT	206 11TH ST	LS		\$0

A-126	PRIVATE-SIDE REPLACEMENT	509 11TH ST	LS		\$0
A-127	PRIVATE-SIDE REPLACEMENT	522 11TH ST	LS		\$0
A-128	PRIVATE-SIDE REPLACEMENT	514 11TH ST	LS		\$0
A-129	PRIVATE-SIDE REPLACEMENT	424 11TH ST	LS		\$0
A-130	PRIVATE-SIDE REPLACEMENT	319 11TH ST	LS		\$0
A-131	PRIVATE-SIDE REPLACEMENT	415 12TH ST	LS		\$0
A-132	PRIVATE-SIDE REPLACEMENT	308 12TH ST	LS		\$0
A-133	PRIVATE-SIDE REPLACEMENT	312 12TH ST	LS		\$0
A-134	PRIVATE-SIDE REPLACEMENT	208 12TH ST	LS		\$0
A-135	PRIVATE-SIDE REPLACEMENT	504 12TH ST	LS		\$0
A-136	PRIVATE-SIDE REPLACEMENT	623 13TH ST	LS		\$0
A-137	PRIVATE-SIDE REPLACEMENT	621 13TH ST	LS		\$0
A-138	PRIVATE-SIDE REPLACEMENT	315 13TH ST	LS		\$0
A-139	PRIVATE-SIDE REPLACEMENT	301 13TH ST	LS		\$0
A-140	PRIVATE-SIDE REPLACEMENT	225 13TH ST	LS		\$0
A-141	SPECIAL- DISCONNECT SERVICE FROM MAIN LINE	near 500 6TH AVE	LS		\$0
A-142	SPECIAL- DISCONNECT SERVICE FROM MAIN LINE	211 13TH ST	LS		\$0
A-143	SPECIAL- DISCONNECT TEE BRANCH FROM SERVICE LINE	1602 11TH AVE	LS		\$0
A-144	SPECIAL - REPLACE CURBSTOP AND METER PIG TAIL.	106 N 9TH AVE	LS		\$0
TOTAL SCHEDULE A PHASE 02 BID PRICE					\$100,000

SCHEDULE B - OTHER BID ITEMS / STANDARD PRICING					
Item No.	Work & Material	Quantity	Unit of Measure	Unit Price	Total Amount
B-1	PUBLIC Service Line Replacement, main to curbstop (Assume 40' Length, 3/4" service line, located in asphalt road)	1	EA		\$0
B-2	PRIVATE Service Line Replacement, meter to first fitting in the building (Assume 40' Length, 3/4" service line, in softscape without turf)	1	EA		\$0
B-3	FULL Service Line Replacement, main to first fitting in the building (Assume 80' total length, 3/4" service line – half asphalt, half softscape)	1	EA		\$0
B-4	Curbstop Replacement	1	EA		\$0
B-5	Meter Pit Installation including Meter Setter and Fittings	1	EA		\$0
B-6	Connector Replacement, Curbstop to Meter Pit (Assume 2' 3/4 inch copper)	1	EA		\$0
B-7	HomeOwner Work Plan Vist	1	EA		\$0

B-8	Concrete Flatwork	100	SF		\$0
B-9	Flagger	1	Day		\$0
B-10	Uniformed Traffic Control	1	Day		\$0
B-11	6" Saddle Tap	1	EA		\$0
B-12	8" Saddle Tap	1	EA		\$0
B-13	6" Oversize Saddle Tap Repair Sleeve	1	EA		\$0
B-14	6" Water Main Repair Sleeve	1	EA		\$0
B-15	Interior Service Relocation - 3/4" Copper or Cross-Linked PEX - Assume 25 LF	1	EA		\$0
B-16	House Service Abandonment (Cut and Cap) (2" or less services)	1	EA		\$0
B-17	Abandon/Remove 2" or less Service Line Meter Pit/Manhole	1	EA		\$0
B-18	Hydro-Excavation (potholing)	1	Day		\$0
B-19	Licensed Master Plumber	1	Day		\$0
B-20	Irrigation Repair	1	EA		\$0
B-21	CLSM (Flow Fill)	10	CY		\$0
B-22	Installation of Grass Sod	100	SF		\$0
B-23	Fence removal and replacement (panel)	1	EA		\$0
B-24	Reconnect Irrigation Service	1	EA		\$0
B-25	Replace Sidewalk Section	15	SF		\$0
B-26	Replace Curb and Gutter	5	LF		\$0
TOTAL SCHEDULE B PRICING					\$0

B. Period of Award

The selection of the successful Contractors is anticipated to occur in July 2024.

If the City desires to extend the contract, no later than thirty (30) days prior to expiration, the City's Purchasing Contact may send a notice in writing to the vendor requesting firm pricing for the next twelve-month period. After the City evaluates the firm pricing proposal from the vendor, it will determine whether to extend the contract. All awards and extensions are subject to annual appropriation of funds. The provisions of the foregoing paragraphs with respect to extensions of the terms of the contract shall be null and void if the contract has been terminated or revoked during the initial term or any extension thereof. All decisions to extend the contract are at the option of the City.

C. Minimum Mandatory Qualifications of Offeror

Proposals will only be considered from companies which meet or exceed the criteria listed below.

1. An absence of any previous litigation activities involving another municipal client
2. Proposals will only be accepted from Contractors that have verifiable experience in performing a similar scope of work for at least 3 utilities in Colorado and can demonstrate experience in urban corridors. The proposer shall provide a detailed list of other similar or larger (in size) clients and the associated scope of services that the Contractor completed.
3. Key personnel to be involved in project must have been actively involved in the management or implementation of a similar project previously (as referenced above).

4. The qualified Contractor shall demonstrate resources and experience necessary to execute the work required for service line replacement, installation, site restoration, as well as their ability to work within the City of Greeley Water & Sewer Department and with City of Greeley Customers. Contractors shall demonstrate their (and subcontractors) knowledge in the various work areas, including, but not limited to:
 - Compliance with Colorado State Revolving Fund Required Specifications detailed in Exhibit 5
 - Safety and Security
 - Site Access
 - Traffic Control
 - Potholing Methods
 - Construction Equipment
 - Open Trench Excavation and Service Line Replacement
 - Directional Drilling (Boring) Methods for Service Line Replacement
 - Other trenchless Methods for Service Line Replacement
 - Plumbing (Licensed Plumbers are required)
 - Tapping Oversized Cast Iron, pre-1999 PVC and Concrete Asbestos Water Mains
 - Concrete and Asphalt Repairs and Overall Cleanup
 - Landscape Restoration and Irrigation Repairs
 - Construction Methods, Sequencing, Schedule, and Cost
 - Quality Program including Materials Testing
 - Interaction with Involved Agencies / Stakeholders / Customers
 - Experience with Local Community Interactions and Coordination with Private Property Owners
 - Protecting trees and plantings as appropriate
 - Knowledge of City of Greeley Public Works Construction Specifications and Water and Sewer Engineering Standards

The City of Greeley expects that interested contractors will be qualified in water utility construction services with a proven track record of safety, quality, and successfully utilizing teamwork and innovative methods. The knowledge areas identified can be accomplished through subcontracting.

SECTION III. ADMINISTRATIVE INFORMATION

A. Issuing Office

The City's contact name listed herein is to be the sole point of contact concerning this RFP. Offerors shall not directly contact other personnel regarding matters concerning this RFP or to arrange meetings related to such.

B. Official Means of Communication

All official communication from the City to offerors will be via postings on an electronic solicitation notification system, the Rocky Mountain Bid System (www.rockymountainbidsystem.com). The Purchasing Contact will post notices that will include, but not be limited to, proposal document, addenda, award announcement, etc. It is incumbent upon offerors to carefully and regularly monitor the Rocky Mountain Bid System for any such postings.

C. Inquiries

Prospective offerors may make written inquiries by e-mail before the written inquiry deadline concerning this RFP to obtain clarification of requirements. There will be opportunity to make inquiries during the pre-proposal conference, if any. No inquiries will be accepted after the deadline. Inquiries regarding this RFP (be sure to reference RFP number) shall be referred to:

E-Mail: Purchasing@greeleygov.com

Subject Line: RFP #F24-05-048

Response to offerors' inquiries will be published as addenda on the Rocky Mountain Bid System in a timely manner. Offerors cannot rely on any other statements that clarify or alter any specification or other term or condition of the RFP.

Should any interested offeror, sales representative, or manufacturer find any part of the listed specifications, terms and conditions to be discrepant, incomplete, or otherwise questionable in any respect, it shall be the responsibility of the concerned party to notify the Purchasing Contact of such matters immediately upon discovery.

D. Insurance

The successful Contractor will be required to provide a Certificate of Insurance (Exhibit 3) or other proof of insurance naming the City of Greeley as "additional insured". Coverage must include COMMERCIAL GENERAL LIABILITY coverage with minimum limits of \$2,000,000, and WORKER'S COMPENSATION coverage with limits in accordance with State of Colorado requirements.

COMPREHENSIVE AUTOMOBILE LIABILITY with minimum limits for bodily injury and property damage coverage of at least \$1,000,000, plus an additional amount adequate to pay related attorneys' fees and defense costs, for each of Consultant's owned, hired or non-owned vehicles assigned to or used in performance of this Agreement.

The City shall be named as additional Insured for General and Auto Liability Insurance.

E. Modification or Withdrawal of Proposals

Proposals may be modified or withdrawn by the offeror prior to the established due date and time.

F. Minor Informalities

Minor informalities are matters of form rather than substance evident from the response or insignificant mistakes that can be waived or corrected without prejudice to other vendors. The Purchasing Manager may waive such informalities or allow the vendor to correct them depending on which is in the best interest of the City.

G. Responsibility Determination

The City will make awards only to responsible vendors. The City reserves the right to assess offeror responsibility at any time in this RFP process and may not make a responsibility determination for every offeror.

H. Acceptance of RFP Terms

A proposal submitted in response to this RFP shall constitute a binding offer. The autographic signature of a person who is legally authorized to execute contractual obligations on behalf of the offeror shall indicate acknowledgment of this condition. A submission in response to this RFP acknowledges acceptance by the offeror of all terms and conditions as set forth herein. An offeror shall identify clearly and thoroughly any variations between its proposal and the RFP in the cover letter. Failure to do so shall be deemed a waiver of any rights to subsequently modify the terms of performance, except as outlined or specified in the RFP.

I. Protested Solicitations and Awards

Right to protest. Any actual or prospective bidder, offeror or contractor who is aggrieved in connection with the solicitation or award of a contract must protest in writing to the City Manager as a prerequisite to seeking judicial relief. Protestors are urged to seek informal resolution of their complaints initially with the Purchasing Manager. A protest shall be submitted within ten (10) calendar days after such aggrieved person knows or should have known of the facts giving rise thereto. A protest with respect to an invitation for bids or request for proposals shall be submitted in writing prior to the opening of bids or the closing date of proposals, unless the aggrieved person did not know and should not have known of the facts giving rise to such protests prior to bid opening or the closing date for proposals.

1. Stay of procurement during protests. In the event of a timely protest under Subsection (A) of this Section, the Purchasing Manager shall not proceed further with the solicitation or award of the contract until all administrative and judicial remedies have been exhausted or until the City Manager makes a written determination on the record that the award of a contract without delay is necessary to protect substantial interest of the City. (Ord. 75, 1984 §2 (part))

J. Confidential / Propriety Information

All proposals will be confidential until a contract is awarded and fully executed. At that time, all proposals and documents pertaining to the proposals will be open for public inspection, except for the material that is proprietary or confidential. However, requests for confidentiality can be submitted to the Purchasing Contact provided that the submission is in accordance with the following procedures. This remains the sole responsibility of the offeror. The Purchasing Contact will make no attempt to cure any information that is found to be at a variance with this procedure. The offeror may not be given an opportunity to cure any variances after proposal opening. **Neither a proposal in its entirety, nor proposal price information will be considered confidential/proprietary.** Questions regarding the application of this procedure must be directed to the Purchasing Contact listed in this RFP.

K. Acceptance of Proposal Content

The contents of the proposal (including persons specified to implement the project) of the successful contractor shall become contractual obligations into the contract award. Failure of the successful offeror to perform in accordance with these obligations may result in cancellation of the award and such offeror may be removed from future solicitations.

L. RFP Cancellation

The City reserves the right to cancel this RFP at any time, without penalty.

M. Negotiation of Award

In the event only one (1) responsive proposal is received by the City, the City reserves the right to negotiate the award for the services with the offeror submitting the proposal in lieu of accepting the proposal as is.

N. Contract

A sample copy of the contract award the City will use to contract for the services specified in this RFP is attached as Exhibit 2. The attached contract is only a sample and is not to be completed at this time.

O. RFP Response / Material Ownership

All material submitted regarding this RFP becomes the property of the City of Greeley, unless otherwise noted in the RFP.

P. Incurring Costs

The City is not liable for any cost incurred prior to issuance of a legally executed contract and/or a purchase order.

Q. Utilization of Award by Other Agencies

The City of Greeley reserves the right to allow other State and local governmental agencies, political subdivisions, and/or school districts to utilize the resulting award under all terms and conditions specified and upon agreement by all parties. Usage by any other entity shall not have a negative impact on the City of Greeley in the current term or in any future terms.

R. Non-Discrimination

The offeror shall comply with all applicable state and federal laws, rules and regulations involving non- discrimination on the basis of race, color, religion, national origin, age or sex.

S. News Releases

Neither the City, nor the offeror, shall make news releases pertaining to this RFP prior to execution of the contract without prior written approval of the other party. Written consent on the City's behalf is provided by the Public Information Office.

T. Certification of Independent Price Determination

1. By submission of this proposal each offeror certifies, and in the case of a joint proposal each party, thereto certifies as to its own organization, that in connection with this procurement:
 - a. The prices in this proposal have been arrived at independently, without consultation, communication, or agreement, for the purpose of restricting competition, as to any matter relating to such prices with any other offeror or with any competitor;
 - b. Unless otherwise required by law, the prices which have been quoted in this proposal have not been knowingly disclosed by the offeror and will not knowingly be disclosed by the offeror prior to opening, directly or indirectly to any other offeror or to any competitor; and
 - c. No attempt has been made or will be made by the offeror to induce any other person or firm to submit or not to submit a proposal for the purpose of restricting competition.
2. Each person signing the Request for Proposal form of this proposal certifies that:
 - a. He/she is the person in the offeror's organization responsible within that organization for the decision as to the prices being offered herein and that he/she has not participated, and will not participate, in any action contrary to (1.a) through (1.c) above; or
 - b. He/she is not the person in the offeror's organization responsible within that organization for the decision as to the prices being offered herein but that he/she has been authorized in writing to act as agent for the persons responsible for such decision in certifying that such persons have not participated, and will not participate, in any action contrary to (1.a) through (1.c) above, and as their agent does hereby so certify; and he/she has not participated, and will not participate, in any action contrary to (1.a) through (1.c) above.
3. A proposal will not be considered for award where (1.a), (1.c), or (2.) above has been deleted or modified. Where (1.b) above has been deleted or modified, the proposal will not be considered for award unless the offeror furnishes with the proposal a signed statement which sets forth in detail the circumstances of the disclosure and the City's Purchasing Manager, or designee, determines that such disclosure was not made for the purpose of restricting competition.

4. The Contract Documents may be executed in two or more counterparts, each of which shall be deemed an original but all of which together shall constitute one and the same document. The Contract Documents, including all component parts set forth above, may be executed and delivered by electronic signature by any of the parties and all parties consent to the use of electronic signatures.

U. Taxes

The City of Greeley is exempt from all federal excise taxes and all Colorado State and local government sales and use taxes. Where applicable, contractor will be responsible for payment of use taxes.

V. Assignment of Delegation

Neither party to any resulting contract may assign or delegate any portion of the agreement without the prior written consent of the other party.

W. Availability of Funds

Financial obligations of the City of Greeley payable after the current fiscal year are contingent upon funds for that purpose being appropriated, budgeted and otherwise made available. In the event funds are not appropriated, any resulting contract will become null and void without penalty to the City.

X. Standard of Conduct

The successful firm shall be responsible for maintaining satisfactory standards of employees' competency, conduct, courtesy, appearance, honesty, and integrity, and shall be responsible for taking such disciplinary action with respect to any employee as may be necessary.

The City may request the successful firm to immediately remove from this assignment any employee found unfit to perform duties due to one or more of the following reasons:

1. Neglect of duty.
2. Disorderly conduct, use of abusive or offensive language, quarreling, intimidation by words or actions or fighting.
3. Theft, vandalism, immoral conduct or any other criminal action.
4. Selling, consuming, possessing, or being under the influence of intoxicants, including alcohol, or illegal substances while on assignment for the City.

Agents and employees of Contractor or Consultant working in City facilities shall present a clean and neat appearance. Prior to performing any work for the City, the Contractor or Consultant shall require each of their employees to wear ID badges or uniforms identifying: the Contractor or Consultant by name, the first name of their employee and a photograph of their employee if using an ID badge. Their employee shall wear or attach the ID badge to the outer garments at all times.

Y. Damages for Breach of Contract

In addition to any other legal or equitable remedy the City may be entitled to for a breach of this Contract, if the City terminates this Contract, in whole or in part, due to Contractor's breach of any provision of this Contract, Contractor shall be liable for actual and consequential damages to the City.

Z. Other Statutes

1. The signatory hereto avers that he/she is familiar with Colorado Revised Statutes, 18-8-301, et seq. (Bribery and Corrupt Influence) and 18-8-401, et seq. (Abuse of Public Office) as amended, and that no violation such provisions is present.
2. The signatory hereto avers that to his/her knowledge, no City of Greeley employee has any personal or beneficial interest whatsoever in the service or property described herein. See CRS 24-18-201 and CRS 24-50-507.

SECTION IV. PROPOSAL SUBMISSION

Following are the response requirements for this RFP. All specific response items represent the minimum information to be submitted. Deletions or incomplete responses in terms of content or aberrations in form may, at the City's discretion, render the proposal non-responsive.

RFP responses must be emailed to **purchasing@greeleygov.com**. Only emails sent to **purchasing@greeleygov.com** will be considered as responsive to the request for proposals. DO NOT submit your RFP Response to multiple email addresses. Emails sent to other City emails will be considered as non-responsive and will not be reviewed.

Proposals shall be submitted in a single Microsoft Word or PDF file under 20MB. The Proposal must not exceed 20 total pages, excluding cover letter, index or table of contents, front and back covers, and title pages/separation tabs. Pages shall be 8 ½ x 11 inches except for up to four (4) pages of 11 x 17 inches. Eleven-point font or larger must be used for the proposal and appendices. Resumes included as an appendix are not considered part of the 20 pages.

The RFP number and Project name must be noted in the subject line, otherwise the proposal may be considered as non-responsive to the RFP.

Electronic submittals will be held, un-opened, until the time and date noted in the RFP documents or Posted addenda.

To facilitate the evaluation, offeror shall submit and organize all responses in the same order as listed in Section V. Proposals that are determined to be at a variance with this requirement may not be accepted.

Late proposals will not be accepted. It is the responsibility of the offeror to ensure that the proposal is received at the City of Greeley's Purchasing Division on or before the proposal due date and time.

SECTION V. RESPONSE FORMAT & NARRATIVE

The following items are to be included in your proposal, in the order listed. Deviation from this may render your proposal non-responsive.

A. Cover Letter

Include a cover letter introducing your company, summarizing your qualifications, and detailing any exceptions to this RFP (please note that significant exceptions may make your proposal non-responsive). This letter shall also provide principal contact information for this RFP, including address, telephone number, fax number, e-mail, and website (if applicable).

B. Use of Subcontractors / Partners

There may be areas for use of subcontractors or partners in this project. If you are utilizing this approach, your proposal must list the subcontractors/partners, their area(s) of expertise, and include all other applicable information herein requested for each subcontractor/partner. Please keep in mind that the City will contract solely with your company, therefore subcontractors/partners remain your sole responsibility.

C. Minimum Mandatory Qualifications

Include an itemized description of how your company meets each of the minimum mandatory qualifications outlined in Section II, C. Failure to meet or exceed these requirements will disqualify your response.

D. Company Information

1. Provide the following information as listed: Company Name, Address, Phone Number, and Names of Principals.

2. Identify the year in which your company was established and began providing consulting services.
3. Describe any pending plans to sell or merge your company.
4. Provide a comprehensive listing of all the services you provide.

E. Evaluation Criteria

Evaluation Criterion #1 - Company and Personnel Qualifications

1. Describe your customer service philosophy. The City of Greeley WATER SERVICE LINE REPLACEMENT PROJECT Contract specifies the Contractor to provide a 2-year warranty on all work. The City of Greeley Water & Sewer Department will receive calls from customers asking questions which will generate questions needing to be answered by the Contractor including warranty items. Explain in detail the Contractor's experience and approach in addressing Customers questions as well as warranty items.
2. Status / progress updates and continual process improvement is very important to the City of Greeley. How does the Contractor intend to communicate work progress and issues to the City of Greeley?
3. What examples of process improvements that result in cost savings, improved replacement rates, etc. do you have?
4. Provide information from at least three accounts of similar scope. Include, at a minimum, the following information:
 - a. Company/Municipality Name
 - b. Contact Name
 - c. Phone Number
 - d. Email Address
 - e. Brief description of project scope
 - f. Status of project.

The City reserves the right to contact the references provided in your proposal as well as other references without prior notification to you.

5. Provide the names and resumes of the key personnel that will be performing the proposed services, including the primary project manager and personal having direct communications with customers.
6. List the names of the subcontractors you expect to use, the services to be provided by the subcontractors and the amount of time that each is expected to spend on the project. Also, include the names and resumes of the key subcontractor personnel who will be working on the project.

Evaluation Criterion #2 – Approach to Scope of Work

In response to this RFP, the proposer shall provide a written narrative detailing the Contractor's philosophy, means and methods, resources, equipment, and overall approach to replace all or portions of a City of Greeley identified service lines under a WATER SERVICE LINE REPLACEMENT PROJECT Contract.

The proposer's narrative shall answer the following in discussing their project approach:

1. What is the Contractor's approach to performing service line replacements for Phase 02? The City of Greeley would like to understand the Contractor's approach to completing these replacements, specifically detailing: concept of operations, size and skills of replacement crews, replacement equipment utilized, and the estimated timeline to complete a service line replacement. What is the expected timeline to complete Phase 02 and how many crews would be utilized?
2. The Contractor will be required to work closely with City of Greeley Public Works Department in obtaining right of way permits, as well as work with other City departments on securing plumbing permits. Please

describe how the Contractor will work with these departments to secure, track the status of, and close out applicable permits.

3. What is the Contractor's safety approach and how will that be implemented?
4. What method(s) of service line installation will you employ? The City of Greeley welcomes Contractor input and comments on providing other innovative approaches to consider in terms of means and methods to replace service lines.
5. Describe any project approaches or ideas that you would apply to this project and that you feel would enhance the quality of your services or reduce project costs.
6. Describe how the team will handle quality control, specifically how water service line replacement issues would be monitored and resolved.
7. Explain how the contractor will track and document meet the requirements of State and Federal project requirements detailed in **Exhibit 5 CO SRF Required Specifications**

Evaluation Criterion #3 - Value/Cost of Efforts

1. What is the Contractor's strategy for cost management under the WATER SERVICE LINE REPLACEMENT PROJECT Contract and methodology used to track and control costs?
2. Describe the Contractor's Quality Management Processes. Contractor shall discuss unit bid item tracking, preparation of invoices, project materials handling and tracking, and permits.
3. Provide a cost for the services and products broken down per task listed under the **Scope of Services**, above. Show a breakdown of all reimbursable expenses required to complete the work. If applicable, the subcontractors' costs must be shown as separate items. Also, provide hourly rates for your firm and all subcontractors. These rates will be considered valid throughout the project.

F. Proposal Acknowledgement

Include this form as provided in Exhibit 1.

G. Certificate of Insurance

A sample Certificate of Insurance is provided in Exhibit 3.

H. Debarment Form

Include this form as provided in Exhibit 4.

SECTION VI. EVALUATION AND AWARD

A. Proposal Evaluation

All proposals submitted in response to this RFP will be evaluated by a committee in accordance with the criteria described below. Total scores will be tabulated, and the highest ranked firm will enter into negotiations.

If the City requests presentations by short-listed offerors, committee members may revise their initial scores based upon additional information and clarification received in this phase. Please note that presentations have been tentatively scheduled per the Schedule of Events on the first page of this RFP. If your company is invited to give a presentation to the committee, these dates may not be flexible.

In preparing responses, offerors shall describe in great detail how they propose to meet the specifications as detailed in the previous sections. Specific factors will be applied to proposal information to assist the City in selecting the most qualified offeror for this contract. Following is the evaluation criteria that will be used. Criteria will be assigned a points value.

List Evaluation Criteria here:

- | | |
|--|-----------|
| 1. Company and Personnel Qualifications: | 40 Points |
| 2. Approach to Scope of Work: | 40 Points |
| 3. Value/Cost of Efforts: | 20 Points |

A presentation and/or demonstration may be requested by short-listed offerors prior to award. However, a presentation/demonstration may not be required, and therefore, complete information shall be submitted with your proposal.

B. Determination of Responsibility of the Offeror

The City of Greeley awards contracts to responsible vendors only. The City reserves the right to make its offeror responsibility determination at any time in this RFP process and may not make a responsibility determination for every offeror.

The City of Greeley's Municipal Code defines a "Responsible Offeror" as one who has "the capability in all respects to perform fully the contract requirements, and the tenacity, perseverance, experience, integrity, reliability, capacity, facilities, equipment, and credit which will assure good faith performance." The City reserves the right to request information as it deems necessary to determine an offeror's responsibility. If the offeror fails to supply the requested information, the City shall base the determination of responsibility upon any available information or may find the offeror non-responsible if such failure is unreasonable.

COOPERATIVE PURCHASING STATEMENT

The City of Greeley encourages and participates in cooperative purchasing endeavors undertaken by or on behalf of other governmental jurisdictions. To the extent, other governmental jurisdictions are legally able to participate in cooperative purchasing endeavors; the City of Greeley supports such cooperative activities. Further, it is a specific requirement of this proposal or Request for Proposal that pricing offered herein to the City of Greeley may be offered by the vendor to any other governmental jurisdiction purchasing the same products. The vendor(s) must deal directly with any governmental agency concerning the placement of purchase orders, contractual disputes, invoicing, and payment. The City of Greeley shall not be liable for any costs or damages incurred by any other entity.

**EXHIBIT 1
PROPOSAL ACKNOWLEDGEMENT**

The offeror hereby acknowledges receipt of addenda numbers _____ through _____.

Falsifying this information is cause to deem your proposal nonresponsive and therefore ineligible for consideration. In addition, falsification of this information is cause to cancel a contract awarded based on one or both of the above preferences.

By signing below, you agree to all terms & conditions in this RFP, except where expressly described in your cover letter.

Original Signature by Authorized Officer/Agent

Type or printed name of person signing

Company Name

Title

Phone Number

Vendor Mailing Address

Website Address

City, State, Zip

Proposal Valid Until (at least for 90 days)

E-Mail Address

Project Manager:

Name (Printed)

Phone Number

Vendor Mailing Address

Email Address

City, State, Zip

**EXHIBIT 2
SAMPLE CONTRACT**

[F24-05-048](#)

DEBARMENT / SUSPENSION CERTIFICATION STATEMENT

The proposer certifies that neither it nor its principals are presently debarred, suspended, proposed for debarment, declared ineligible or voluntarily excluded from participation in this transaction by any Federal, State, County, Municipal or any other department or agency thereof. The proposer certifies that it will provide immediate written notice to the City if at any time the proposer learns that its certification was erroneous when submitted or has become erroneous by reason of changed circumstance.

DUNS # (Optional)_____

Name of Organization_____

Address_____

Authorized Signature_____

Title_____

Date_____

CO SRF Required Specifications INSTRUCTIONS

(SRF Equivalency)

STEPS:

1. The following specifications must be inserted in their entirety into the project construction specification documents for bidding and for construction. This includes material, supplies and equipment procurement contracts.
2. Bid advertisements must be posted for a minimum of 30 days prior to bid opening. The bid advertisement should include the following statement or similar: *“This project anticipates funding from the Colorado State Revolving Fund (SRF) loan program. Bidder’s attention is called to the SRF requirements in the bid package. Disadvantaged Business Enterprise (DBE) requirements and goals are included. Also, certified DBEs or a consortium of certified DBEs are encouraged to bid.”*
3. The following information must be input into the specifications by the Owner representative prior to bidding and contract execution:
 - a. **Section 1:** Insert the current Davis-Bacon Wage general decision number. **The decision number must be verified 10-days prior to bid opening and updated if a new decision has been published.** See Section 1 for instructions.
 - b. **Section 1:** A copy of the current published Davis-Bacon wage determination document must be attached and the attachment number provided.
 - c. **Section 4:** The applicable Colorado county (or counties) must be inserted.
4. The following certifications must be completed and submitted by the prime contractor with their bid:
 - a. [Suspension and Debarment Certification Form](#)
 - b. [DBE 6100-4](#) and [6100-3](#) Forms

If you have any questions regarding the specifications contained in this document, please contact your SRF program Project Manager from the list below. You may also contact the Unit Manager, Work Group Lead or the Compliance Specialist as needed.

IMPORTANT: Prior to construction, the project must receive environmental clearance and engineering final design approval from the Water Quality Control Division. If you have any questions regarding the status of these clearances and approvals please contact your SRF program Project Manager.

Name	Title	Phone	Email
Mark Henderson	Unit Manager	720-258-6450	mark.henderson@state.co.us
Alex Hawley	Work Group Lead	720-248-8095	alex.hawley@state.co.us
Erick Worker	Project Manager	303-692-3594	erick.worker@state.co.us
Aly Ulibarri	Project Manager	720-295-9634	aly.ulibarri@state.co.us
James Wheatley	Project Manager	720-248-7364	james.wheatley@state.co.us
Matt Alms	Compliance Specialist	720-263-1530	matt.als@state.co.us
Jeff Zajdel	Project Manager	720-235-8828	jeff.zajdel@state.co.us
Sean Oliver	Project Manager	720-446-9073	sean.oliver@state.co.us



Colorado State Revolving Fund Required Specifications

(SRF Equivalency)

Table of Contents

[Section 1: Davis-Bacon Prevailing Wage Requirements](#)

[Section 2: American Iron and Steel](#)

[Section 3: National Term on Suspension and Debarment](#)

[Section 4: Equal Employment Opportunity](#)

[Section 5: Williams-Steiger Occupational Safety and Health Act of 1970](#)

[Section 6: Discovery of Archaeological and Other Historical Items](#)

[Section 7: Disadvantaged Business Enterprise \(DBE\) - SRF Program Grant Agreement Information and Requirements](#)

[Section 8: Prohibition on Certain Telecommunication and Video Surveillance Services or Equipment](#)

[Section 9: Signage Requirements](#)

[Section 10: Build America, Buy America \(BABA\)](#)

[Section 11: SRF Required Forms by Section](#)

Section 1

Davis Bacon Prevailing Wage Requirements

This contract is governed by the Davis Bacon and Related Acts and is subject to General Decision Number CO _____ dated _____.

A copy of this General Decision Number is attached as _____ to this document.

The SRF Program is subject to Davis Bacon and Related Acts, which extends the requirements of the Davis-Bacon Act. Compliance with the Davis-Bacon Act is required for any project funded by the Drinking Water Revolving Fund (DWRP) or Water Pollution Control Revolving Fund (WPCRF) programs. Non-Compliance with the Davis-Bacon Act may result in debarment and suspension from working on future projects funded with federal dollars for up to three years and/or loss of funding for the current project.

Preamble

With respect to the Clean Water and Safe Drinking Water State Revolving Funds, EPA provides capitalization grants to each State which in turn provides sub-grants or loans to eligible entities within the State. Typically, the subrecipients are municipal or other local governmental entities that manage the funds. For these types of recipients, the provisions set forth under Roman numeral I, below, shall apply. Although EPA and the State remain responsible for ensuring subrecipients' compliance with the wage rate requirements set forth herein, those subrecipients shall have the primary responsibility to maintain payroll records as described in Section 3(ii)(A), below and for compliance as described in Section I - 5.

Attachment 1

Wage Rate Requirements under:

- The Consolidated Appropriations Act, 2016 (P.L 114-133), or
- The Water Resources Reform and Redevelopment Act of 2014 (WRRDA):

I. For Subrecipients that Are Governmental Entities:

The following terms and conditions specify how recipients will assist EPA in meeting its Davis - Bacon (DB) responsibilities when DB applies to EPA awards of financial assistance under The 2014 Act with respect to State recipients and subrecipients that are governmental entities. If a subrecipient has questions regarding when DB applies, obtaining the correct DB wage determinations, DB provisions, or compliance monitoring, it may contact the State recipient. The recipient or subrecipient may also obtain additional guidance from US Department of Labor (DOL) web site at

<https://www.dol.gov/agencies/whd/government-contracts/construction>

1. Applicability of the Davis-Bacon (DB) prevailing wage requirements.

Under The Consolidated Appropriations Act, 2016, or The Water Resources Reform and Redevelopment Act of 2014, DB prevailing wage requirements apply to the construction, alteration, and repair of treatment works carried out in whole or in part with assistance made available by a State water pollution control revolving fund and to any construction project carried out in whole or in part by assistance made available by a drinking water treatment revolving loan fund. If a subrecipient encounters a unique situation at a site that presents uncertainties regarding DB applicability, the subrecipient must discuss the situation with the recipient State before authorizing work on that site.

2. Obtaining Wage Determinations.

- (a) Subrecipients shall obtain the wage determination for the locality in which a covered activity subject to DB will take place prior to issuing requests for bids, proposals, quotes or other methods for soliciting contracts (solicitation) for activities subject to DB. These wage determinations shall be incorporated into solicitations and any subsequent contracts. Prime contracts must contain a provision requiring that subcontractors follow the wage determination incorporated into the prime contract.
 - (1) While the solicitation remains open, the subrecipient shall monitor <https://sam.gov/> weekly to ensure that the wage determination contained in the solicitation remains current. The subrecipients shall amend the solicitation if DOL issues a modification more than 10 days prior to the closing date (i.e. bid opening) for the solicitation. If DOL modifies or supersedes the applicable wage determination less than 10 days prior to the closing date, the subrecipients may request a finding from the State recipient that there is not a reasonable time to notify interested contractors of the modification of the wage determination. The State recipient will provide a report of its findings to the subrecipient.
 - (2) If the subrecipient does not award the contract within 90 days of the closure of the solicitation, any modifications or supersedes DOL makes to the wage determination contained in the solicitation shall be effective unless the State recipient, at the request of the subrecipient, obtains an extension of the 90 day period from DOL pursuant to 29 CFR 1.6(c)(3)(iv). The subrecipient shall monitor <https://sam.gov/> on a weekly basis if it does not award the contract within 90 days of closure of the solicitation to ensure that wage determinations contained in the solicitation remain current.
- (b) If the subrecipient carries out activity subject to DB by issuing a task order, work assignment or similar instrument to an existing contractor (ordering instrument) rather than by publishing a solicitation, the subrecipient shall insert the appropriate DOL wage determination from <https://sam.gov/> into the ordering instrument.
- (c) Subrecipients shall review all subcontracts subject to DB entered into by prime contractors to verify that the prime contractor has required its subcontractors to include the applicable wage determinations.
- (d) As provided in 29 CFR 1.6(f), DOL may issue a revised wage determination applicable to a subrecipient's contract after the award of a contract or the issuance of an ordering instrument if DOL determines that the subrecipient has failed to incorporate a wage determination or has used a wage determination that clearly does not apply to the contract or ordering instrument. If this occurs, the subrecipient shall either terminate the contract or ordering instrument and issue a revised solicitation or ordering instrument or incorporate DOL's wage determination retroactive to the beginning of the contract or ordering instrument by change order. The subrecipient's contractor must be compensated for any increases in wages resulting from the use of DOL's revised wage determination.

3. Contract and Subcontract provisions.

- (a) The Recipient shall insure that the subrecipient(s) shall insert in full in any contract in excess of \$2,000 which is entered into for the actual construction, alteration and/or repair, including painting and decorating, of a treatment works under the Clean Water State Revolving Fund (CWSRF) or a construction project under the Drinking Water State Revolving Fund (DWSRF) financed in whole or in part from Federal funds or in accordance with guarantees of a Federal agency or financed from funds obtained by pledge of any contract of a Federal agency to make a loan, grant or annual contribution (except where a different meaning is expressly indicated), and which is subject to the labor standards provisions of any of the acts listed in § 5.1 or The 2014 Act, the following clauses:

(1) Minimum wages.

- (i) All laborers and mechanics employed or working upon the site of the work will be paid unconditionally and not less often than once a week, and without subsequent deduction or rebate on any account (except such payroll deductions as are permitted by regulations issued by the Secretary of Labor under the Copeland Act (29 CFR part 3)), the full amount of wages and bona fide fringe benefits (or cash equivalents thereof) due at time of payment computed at rates not less than those contained in the wage determination of the Secretary of Labor which is attached hereto and made a part hereof, regardless of any contractual relationship which may be alleged to exist between the contractor and such laborers and mechanics.

Contributions made or costs reasonably anticipated for bona fide fringe benefits under section 1(b)(2) of the Davis-Bacon Act on behalf of laborers or mechanics are considered wages paid to such laborers or mechanics, subject to the provisions of paragraph (a)(1)(iv) of this section; also, regular contributions made or costs incurred for more than a weekly period (but not less often than quarterly) under plans, funds, or programs which cover the particular weekly period, are deemed to be constructively made or incurred during such weekly period. Such laborers and mechanics shall be paid the appropriate wage rate and fringe benefits on the wage determination for the classification of work actually performed, without regard to skill, except as provided in § 5.5(a)(4). Laborers or mechanics performing work in more than one classification may be compensated at the rate specified for each classification for the time actually worked therein: Provided that the employer's payroll records accurately set forth the time spent in each classification in which work is performed. The wage determination (including any additional classification and wage rates conformed under paragraph (a)(1)(ii) of this section) and the Davis-Bacon poster (WH-1321) shall be posted at all times by the contractor and its subcontractors at the site of the work in a prominent and accessible place where it can be easily seen by the workers.

Subrecipients may obtain wage determinations from the U.S. Department of Labor's web site, <https://sam.gov/>

- (ii) (A) The subrecipient(s), on behalf of EPA, shall require that any class of laborers or mechanics, including helpers, which is not listed in the wage determination and which is to be employed under the contract shall be classified in conformance with the wage determination. The State award official shall approve a request for an additional classification and wage rate and fringe benefits therefore only when the following criteria have been met:
- (1) The work to be performed by the classification requested is not performed by a classification in the wage determination; and
 - (2) The classification is utilized in the area by the construction industry; and
 - (3) The proposed wage rate, including any bona fide fringe benefits, bears a reasonable relationship to the wage rates contained in the wage determination.
- (B) If the contractor and the laborers and mechanics to be employed in the classification (if known), or their representatives, and the subrecipient(s) agree on the classification and wage rate (including the amount designated for fringe benefits where appropriate), documentation of the action taken and the request, including the local wage determination shall be sent by the subrecipient(s) to the State award official. The State award official will transmit the request to the Administrator of the Wage and Hour Division, Employment Standards Administration, U.S. Department of Labor, Washington, DC 20210. The Administrator, or an authorized representative, will approve, modify, or disapprove every additional classification request within 30 days

of receipt and so advise the State award official or will notify the State award official within the 30-day period that additional time is necessary.

- (C) In the event the contractor, the laborers or mechanics to be employed in the classification or their representatives, and the subrecipient(s) do not agree on the proposed classification and wage rate (including the amount designated for fringe benefits, where appropriate), the award official shall refer the request and the local wage determination, including the views of all interested parties and the recommendation of the State award official, to the Administrator for determination. The Administrator, or an authorized representative, will issue a determination within 30 days of receipt of the request and so advise the contracting officer or will notify the contracting officer within the 30-day period that additional time is necessary.
 - (D) The wage rate (including fringe benefits where appropriate) determined pursuant to paragraphs (a)(1)(ii)(B) or (C) of this section, shall be paid to all workers performing work in the classification under this contract from the first day on which work is performed in the classification.
- (iii) Whenever the minimum wage rate prescribed in the contract for a class of laborers or mechanics includes a fringe benefit which is not expressed as an hourly rate, the contractor shall either pay the benefit as stated in the wage determination or shall pay another bona fide fringe benefit or an hourly cash equivalent thereof.
 - (iv) If the contractor does not make payments to a trustee or other third person, the contractor may consider as part of the wages of any laborer or mechanic the amount of any costs reasonably anticipated in providing bona fide fringe benefits under a plan or program, provided that the Secretary of Labor has found, upon the written request of the contractor, that the applicable standards of the Davis-Bacon Act have been met. The Secretary of Labor may require the contractor to set aside in a separate account assets for the meeting of obligations under the plan or program.

(2) Withholding.

- (i) The subrecipient(s) shall, upon written request of the EPA Award Official or an authorized representative of the Department of Labor, withhold or cause to be withheld from the contractor under this contract or any other Federal contract with the same prime contractor, or any other federally-assisted contract subject to Davis-Bacon prevailing wage requirements, which is held by the same prime contractor, so much of the accrued payments or advances as may be considered necessary to pay laborers and mechanics, including apprentices, trainees, and helpers, employed by the contractor or any subcontractor the full amount of wages required by the contract. In the event of failure to pay any laborer or mechanic, including any apprentice, trainee, or helper, employed or working on the site of the work, all or part of the wages required by the contract, the Federal Agency or State may, after written notice to the contractor, sponsor, applicant, or owner, take such action as may be necessary to cause the suspension of any further payment, advance, or guarantee of funds until such violations have ceased.

(3) Payrolls and basic records.

- (i) Payrolls and basic records relating thereto shall be maintained by the contractor during the course of the work and preserved for a period of three years thereafter for all laborers and mechanics working at the site of the work. Such records shall contain the name, address, and social security number of each such worker, his or her correct classification, hourly rates of wages paid (including rates of contributions or costs anticipated for bona fide fringe benefits or cash equivalents thereof of the types described in section 1(b)(2)(B) of the Davis-Bacon Act), daily and weekly number of hours worked, deductions made and actual

wages paid. Whenever the Secretary of Labor has found under 29 CFR 5.5(a)(1)(iv) that the wages of any laborer or mechanic include the amount of any costs reasonably anticipated in providing benefits under a plan or program described in section 1(b)(2)(B) of the Davis-Bacon Act, the contractor shall maintain records which show that the commitment to provide such benefits is enforceable, that the plan or program is financially responsible, and that the plan or program has been communicated in writing to the laborers or mechanics affected, and records which show the costs anticipated or the actual cost incurred in providing such benefits. Contractors employing apprentices or trainees under approved programs shall maintain written evidence of the registration of apprenticeship programs and certification of trainee programs, the registration of the apprentices and trainees, and the ratios and wage rates prescribed in the applicable programs.

- (ii) (A) The contractor shall submit weekly, for each week in which any contract work is performed, a copy of all payrolls to the subrecipient, that is, the entity that receives the sub-grant or loan from the State capitalization grant recipient. Such documentation shall be available on request of the State recipient or EPA. As to each payroll copy received, the subrecipient shall provide written confirmation in a form satisfactory to the State indicating whether or not the project is in compliance with the requirements of 29 CFR 5.5(a)(1) based on the most recent payroll copies for the specified week. The payrolls shall set out accurately and completely all of the information required to be maintained under 29 CFR 5.5(a)(3)(i), except that full social security numbers and home addresses shall not be included on the weekly payrolls. Instead the payrolls shall only need to include an individually identifying number for each employee (e.g., the last four digits of the employee's social security number). The required weekly payroll information may be submitted in any form desired. Optional Form WH-347 is available for this purpose from the Wage and Hour Division Web site at www.dol.gov/whd/forms/wh347instr.htm or its successor site. The prime contractor is responsible for the submission of copies of payrolls by all subcontractors. Contractors and subcontractors shall maintain the full social security number and current address of each covered worker, and shall provide them upon request to the subrecipient(s) for transmission to the State or EPA if requested by EPA, the State, the contractor, or the Wage and Hour Division of the Department of Labor for purposes of an investigation or audit of compliance with prevailing wage requirements. It is not a violation of this section for a prime contractor to require a subcontractor to provide addresses and social security numbers to the prime contractor for its own records, without weekly submission to the subrecipient(s).
- (B) Each payroll submitted shall be accompanied by a "Statement of Compliance," signed by the contractor or subcontractor or his or her agent who pays or supervises the payment of the persons employed under the contract and shall certify the following:
- (1) That the payroll for the payroll period contains the information required to be provided under § 5.5 (a)(3)(ii) of Regulations, 29 CFR part 5, the appropriate information is being maintained under § 5.5 (a)(3)(i) of Regulations, 29 CFR part 5, and that such information is correct and complete;
 - (2) That each laborer or mechanic (including each helper, apprentice, and trainee) employed on the contract during the payroll period has been paid the full weekly wages earned, without rebate, either directly or indirectly, and that no deductions have been made either directly or indirectly from the full wages earned, other than permissible deductions as set forth in Regulations, 29 CFR part 3;
 - (3) That each laborer or mechanic has been paid not less than the applicable wage rates and fringe benefits or cash equivalents for the classification of work performed, as specified in the applicable wage determination incorporated into the contract.

- (C) The weekly submission of a properly executed certification set forth on the reverse side of Optional Form WH-347 shall satisfy the requirement for submission of the "Statement of Compliance" required by paragraph (a)(3)(ii)(B) of this section.
 - (D) The falsification of any of the above certifications may subject the contractor or subcontractor to civil or criminal prosecution under section 1001 of title 18 and section 231 of title 31 of the United States Code.
- (iii) The contractor or subcontractor shall make the records required under paragraph (a)(3)(i) of this section available for inspection, copying, or transcription by authorized representatives of the State, EPA or the Department of Labor, and shall permit such representatives to interview employees during working hours on the job. If the contractor or subcontractor fails to submit the required records or to make them available, the Federal agency or State may, after written notice to the contractor, sponsor, applicant, or owner, take such action as may be necessary to cause the suspension of any further payment, advance, or guarantee of funds. Furthermore, failure to submit the required records upon request or to make such records available may be grounds for debarment action pursuant to 29 CFR 5.12.
- (4) Apprentices and trainees--
- (i) Apprentices. Apprentices will be permitted to work at less than the predetermined rate for the work they performed when they are employed pursuant to and individually registered in a bona fide apprenticeship program registered with the U.S. Department of Labor, Employment and Training Administration, Office of Apprenticeship Training, Employer and Labor Services, or with a State Apprenticeship Agency recognized by the Office, or if a person is employed in his or her first 90 days of probationary employment as an apprentice in such an apprenticeship program, who is not individually registered in the program, but who has been certified by the Office of Apprenticeship Training, Employer and Labor Services or a State Apprenticeship Agency (where appropriate) to be eligible for probationary employment as an apprentice. The allowable ratio of apprentices to journeymen on the job site in any craft classification shall not be greater than the ratio permitted to the contractor as to the entire work force under the registered program. Any worker listed on a payroll at an apprentice wage rate, who is not registered or otherwise employed as stated above, shall be paid not less than the applicable wage rate on the wage determination for the classification of work actually performed. In addition, any apprentice performing work on the job site in excess of the ratio permitted under the registered program shall be paid not less than the applicable wage rate on the wage determination for the work actually performed. Where a contractor is performing construction on a project in a locality other than that in which its program is registered, the ratios and wage rates (expressed in percentages of the journeyman's hourly rate) specified in the contractor's or subcontractor's registered program shall be observed. Every apprentice must be paid at not less than the rate specified in the registered program for the apprentice's level of progress, expressed as a percentage of the journeymen hourly rate specified in the applicable wage determination. Apprentices shall be paid fringe benefits in accordance with the provisions of the apprenticeship program. If the apprenticeship program does not specify fringe benefits, apprentices must be paid the full amount of fringe benefits listed on the wage determination for the applicable classification. If the Administrator determines that a different practice prevails for the applicable apprentice classification, fringes shall be paid in accordance with that determination. In the event the Office of Apprenticeship Training, Employer and Labor Services, or a State Apprenticeship Agency recognized by the Office, withdraws approval of an apprenticeship program, the contractor will no longer be permitted to utilize apprentices at less than the applicable predetermined rate for the work performed until an acceptable program is approved.
 - (ii) Trainees. Except as provided in 29 CFR 5.16, trainees will not be permitted to work at less than the predetermined rate for the work performed unless they are employed pursuant to

and individually registered in a program which has received prior approval, evidenced by formal certification by the U .S. Department of Labor, Employment and Training Administration. The ratio of trainees to journeymen on the job site shall not be greater than permitted under the plan approved by the Employment and Training Administration. Every trainee must be paid at not less than the rate specified in the approved program for the trainee's level of progress, expressed as a percentage of the journeyman hourly rate specified in the applicable wage determination. Trainees shall be paid fringe benefits in accordance with the provisions of the trainee program. If the trainee program does not mention fringe benefits, trainees shall be paid the full amount of fringe benefits listed on the wage determination unless the Administrator of the Wage and Hour Division determines that there is an apprenticeship program associated with the corresponding journeyman wage rate on the wage determination which provides for less than full fringe benefits for apprentices. Any employee listed on the payroll at a trainee rate who is not registered and participating in a training plan approved by the Employment and Training Administration shall be paid not less than the applicable wage rate on the wage determination for the classification of work actually performed. In addition, any trainee performing work on the job site in excess of the ratio permitted under the registered program shall be paid not less than the applicable wage rate on the wage determination for the work actually performed. In the event the Employment and Training Administration withdraws approval of a training program, the contractor will no longer be permitted to utilize trainees at less than the applicable predetermined rate for the work performed until an acceptable program is approved.

- (iii) Equal employment opportunity. The utilization of apprentices, trainees and journeymen under this part shall be in conformity with the equal employment opportunity requirements of Executive Order 11246, as amended, and 29 CFR part 30.
- (5) Compliance with Copeland Act requirements. The contractor shall comply with the requirements of 29 CFR part 3, which are incorporated by reference in this contract.
- (6) Subcontracts. The contractor or subcontractor shall insert in any subcontracts the clauses contained in 29 CFR 5.5(a)(1) through (10) and such other clauses as the EPA determines may be appropriate, and also a clause requiring the subcontractors to include these clauses in any lower tier subcontracts. The prime contractor shall be responsible for the compliance by any subcontractor or lower tier subcontractor with all the contract clauses in 29 CFR 5.5.
- (7) Contract termination: debarment. A breach of the contract clauses in 29 CFR 5.5 may be grounds for termination of the contract, and for debarment as a contractor and a subcontractor as provided in 29 CFR 5.12.
- (8) Compliance with Davis-Bacon and Related Act requirements. All rulings and interpretations of the Davis-Bacon and Related Acts contained in 29 CFR parts 1, 3, and 5 are herein incorporated by reference in this contract.
- (9) Disputes concerning labor standards. Disputes arising out of the labor standards provisions of this contract shall not be subject to the general disputes clause of this contract. Such disputes shall be resolved in accordance with the procedures of the Department of Labor set forth in 29 CFR parts 5, 6, and 7. Disputes within the meaning of this clause include disputes between the contractor (or any of its subcontractors) and Subrecipient(s), State, EPA, the U.S. Department of Labor, or the employees or their representatives.
- (10) Certification of eligibility.
 - (i) By entering into this contract, the contractor certifies that neither it (nor he or she) nor any person or firm who has an interest in the contractor's firm is a person or firm ineligible

to be awarded Government contracts by virtue of section 3(a) of the Davis-Bacon Act or 29 CFR 5.12(a)(1).

(ii) No part of this contract shall be subcontracted to any person or firm ineligible for award of a Government contract by virtue of section 3(a) of the Davis-Bacon Act or 29 CFR 5.12(a)(1).

(iii) The penalty for making false statements is prescribed in the U .S. Criminal Code, 18 U.S.C. 1001.

4. Contract Provision for Contracts in Excess of \$100,000.

(a) Contract Work Hours and Safety Standards Act. The subrecipient shall insert the following clauses set forth in paragraphs (a)(1), (2), (3), and (4) of this section in full in any contract in an amount in excess of \$100,000 and subject to the overtime provisions of the Contract Work Hours and Safety Standards Act. These clauses shall be inserted in addition to the clauses required by Item 3, above, or 29 CFR 4.6. As used in this paragraph, the terms laborers and mechanics include watchmen and guards.

(1) Overtime requirements. No contractor or subcontractor contracting for any part of the contract work which may require or involve the employment of laborers or mechanics shall require or permit any such laborer or mechanic in any workweek in which he or she is employed on such work to work in excess of forty hours in such workweek unless such laborer or mechanic receives compensation at a rate not less than one and one-half times the basic rate of pay for all hours worked in excess of forty hours in such workweek.

(2) Violation; liability for unpaid wages; liquidated damages. In the event of any violation of the clause set forth in paragraph (a)(1) of this section, the contractor and any subcontractor responsible, therefore shall be liable for the unpaid wages. In addition, such contractor and subcontractor shall be liable to the United States (in the case of work done under contract for the District of Columbia or a territory, to such District or to such territory), for liquidated damages. Such liquidated damages shall be computed with respect to each individual laborer or mechanic, including watchmen and guards, employed in violation of the clause set forth in paragraph (a)(1) of this section, in the sum of \$10 for each calendar day on which such individual was required or permitted to work in excess of the standard workweek of forty hours without payment of the overtime wages required by the clause set forth in paragraph (a)(1) of this section.

(3) Withholding for unpaid wages and liquidated damages. The subrecipient, upon written request of the EPA Award Official or an authorized representative of the Department of Labor, shall withhold or cause to be withheld, from any moneys payable on account of work performed by the contractor or subcontractor under any such contract or any other Federal contract with the same prime contractor, or any other federally-assisted contract subject to the Contract Work Hours and Safety Standards Act, which is held by the same prime contractor, such sums as may be determined to be necessary to satisfy any liabilities of such contractor or subcontractor for unpaid wages and liquidated damages as provided in the clause set forth in paragraph (b)(2) of this section.

(4) Subcontracts. The contractor or subcontractor shall insert in any subcontracts the clauses set forth in paragraph (a)(1) through (4) of this section, and also a clause requiring the subcontractors to include these clauses in any lower tier subcontracts. The prime contractor shall be responsible for compliance by any subcontractor or lower tier subcontractor with the clauses set forth in paragraphs (a)(1) through (4) of this section.

(b) In addition to the clauses contained in Item 3, above, in any contract subject only to the Contract Work Hours and Safety Standards Act and not to any of the other statutes cited in 29

CFR 5.1, the Subrecipient shall insert a clause requiring that the contractor or subcontractor shall maintain payrolls and basic payroll records during the course of the work and shall preserve them for a period of three years from the completion of the contract for all laborers and mechanics, including guards and watchmen, working on the contract. Such records shall contain the name and address of each such employee, social security number, correct classifications, hourly rates of wages paid, daily and weekly number of hours worked, deductions made, and actual wages paid. Further, the Subrecipient shall insert in any such contract a clause providing that the records to be maintained under this paragraph shall be made available by the contractor or subcontractor for inspection, copying, or transcription by authorized representatives of the Federal Agency, State, and the Department of Labor, and the contractor or subcontractor will permit such representatives to interview employees during working hours on the job.

5. Compliance Verification

- (a) The subrecipient shall periodically interview a sufficient number of employees entitled to DB prevailing wages (covered employees) to verify that contractors or subcontractors are paying the appropriate wage rates. As provided in 29 CFR 5.6(a)(6), all interviews must be conducted in confidence. The subrecipient must use Standard Form 1445 (SF 1445) or equivalent documentation to memorialize the interviews. Copies of the SF 1445 are available from EPA on request.
- (b) The subrecipient shall establish and follow an interview schedule based on its assessment of the risks of noncompliance with DB posed by contractors or subcontractors and the duration of the contract or subcontract. Subrecipients must conduct more frequent interviews if the initial interviews or other information indicated that there is a risk that the contractor or subcontractor is not complying with DB. Subrecipients shall immediately conduct interviews in response to an alleged violation of the prevailing wage requirements. All interviews shall be conducted in confidence.
- (c) The subrecipient shall periodically conduct spot checks of a representative sample of weekly payroll data to verify that contractors or subcontractors are paying the appropriate wage rates. The subrecipient shall establish and follow a spot check schedule based on its assessment of the risks of non-compliance with DB posed by contractors or subcontractors and the duration of the contract or subcontract. At a minimum, if practicable, the subrecipient should spot check payroll data within two weeks of each contractor or subcontractor's submission of its initial payroll data and two weeks prior to the completion date the contract or subcontract. Subrecipients must conduct more frequent spot checks if the initial spot check or other information indicates that there is a risk that the contractor or subcontractor is not complying with DB. In addition, during the examinations the subrecipient shall verify evidence of fringe benefit plans and payments there under by contractors and subcontractors who claim credit for fringe benefit contributions.
- (d) The subrecipient shall periodically review contractors and subcontractors use of apprentices and trainees to verify registration and certification with respect to apprenticeship and training programs approved by either the U.S Department of Labor or a state, as appropriate, and that contractors and subcontractors are not using disproportionate numbers of, laborers, trainees and apprentices. These reviews shall be conducted in accordance with the schedules for spot checks and interviews described in Item 5(b) and (c) above.
- (e) Subrecipients must immediately report potential violations of the DB prevailing wage requirements to the EPA DB contact listed above and to the appropriate DOL Wage and Hour District Office listed at:

<https://www.dol.gov/agencies/whd/contact/local-offices>

Section 2

American Iron and Steel

The State Revolving Fund Program is subject to, and requires compliance with, the American Iron and Steel requirement (AIS). American Iron and Steel requires Water Pollution Control State Revolving Fund (WPCRF) and Drinking Water Revolving Fund (DWRf) assistance recipients use iron and steel products that are produced in the United States for projects for the construction, alteration, maintenance, or repair of a public water system or treatment works if the project is funded through an assistance agreement executed on or after January 17, 2014.

In providing bids, proposals, or services, the Contractor represents and warrants to and for the benefit of the borrower and the State that:

- a. The Contractor has reviewed and understands the American Iron and Steel requirement.
- b. All of the iron and steel products used in the project will be and/or have been produced in the United States in a manner that complies with the American Iron and Steel Requirement, unless a waiver of the requirement is approved.
- c. The Contractor will provide any further verified information, certification or assurance of compliance with this paragraph, or information necessary to support a waiver of the American Iron and Steel Requirement, as may be requested by the borrower or the State.

Notwithstanding any other provision of this Agreement, any failure to comply with this paragraph by the Contractor shall permit the borrower or State to recover as damages against the Contractor any loss, expense, or cost (including without limitation attorney's fees) incurred by the borrower or State resulting from any such failure (including without limitation any impairment or loss of funding, whether in whole or in part, from the State or any damages owed to the State by the borrower). While the Contractor has no direct contractual privity with the State, as a lender to the borrower for the funding of its project, the borrower and the Contractor agree that the State is a third-party beneficiary and neither this paragraph (nor any other provision of the Agreement necessary to give this paragraph force or effect) shall be amended or waived without the prior written consent of the State.

For purposes of the WPCRF and DWRf projects that must comply with the AIS requirement, an iron or steel product is one of the following made primarily of iron or steel that is permanently incorporated into the public water system or treatment works:

- Lined or unlined pipes or fittings;
- Manhole Covers;
- Municipal Castings;
- Hydrants;
- Tanks;
- Flanges;
- Pipe clamps and restraints;
- Valves;
- Structural steel;
- Reinforced precast concrete; and
- Construction materials.

If the subrecipient can justify a claim made under one of the categories below, a waiver may be granted. Until a waiver is granted by the EPA, the AIS requirement must be adhered to as described in the act.

A waiver may be provided if EPA determines that:

1. Applying these requirements would be inconsistent with the public interest.
2. Iron and steel products are not produced in the United States in sufficient and reasonably available quantities and of a satisfactory quality.
3. Inclusion of iron and steel products produced in the United States will increase the cost of the overall project by more than 25 percent.

All waiver requests must be routed through the Grants and Loans Unit project manager or compliance specialist.

EPA's guidance on AIS requirements, available at http://water.epa.gov/grants_funding/aisrequirement.cfm includes specific instructions for communities interested in applying for a waiver. After receiving a completed application for a waiver from the Grants and Loans Unit, EPA will publish the waiver request and all material submitted with the application on this website for 15 days. During that period, the public will have the opportunity to review the request and provide informal comment to the EPA.

Approved National Waivers available for borrowers and contractors include:

- April 15, 2014 De Minimis Waiver:

“The EPA is hereby granting a nationwide waiver pursuant to the American Iron and Steel requirements of P.L. 113-76 CAA 2014 (Act), section 436 under the authority of Section 436(b)(1) (public interest waiver) for de minimis incidental components of eligible water infrastructure projects. This action permits the use of products when they occur in de minimis incidental components of such projects funded by the Act that may otherwise be prohibited under section 436(a). Funds used for such de minimis incidental components cumulatively may comprise no more than a total of five percent of the total cost of the material used in and incorporated into a project; the cost of an individual item may not exceed one percent of the total cost of materials used in and incorporated into a project.”

Section 3

National Term on Suspension and Debarment

- I. General Requirements
 - A. Under Executive Order 12549, an individual or organization debarred or excluded from participation in Federal assistance programs or Federal benefit programs may not receive any assistance award under a Federal program, or a subagreement thereunder for \$25,000 or more.
 - B. The status of prospective individuals or organizations can be checked at the System for Award Management(SAM) at <https://sam.gov/content/home>
 - C. Not being debarred or excluded from participation in Federal assistance shall be a condition of the contract in which this specification is included.
 - D. It is the prime contractor's responsibility to verify that subcontractors, vendors, suppliers and manufacturers are not debarred or excluded from participation in Federal assistance programs prior to entering into any agreements or awarding contracts and the prime contractor must verify and document they are not on the excluded parties list.
 - E. Verification can be completed by checking the System for Award Management (<https://sam.gov/content/home>) or by collection of a certification from that person documenting that the person is not excluded; or by adding a clause or condition to the covered transaction with that person indicating that not being excluded is a condition of the agreement. It is strongly recommended to check the System for Award Management.

- II. Demonstrating Compliance
 - A. A prospective prime contractor must submit a completed **Suspension and Debarment Certification Form** (reference Section 11-Forms) along with its bid. Failure to submit the certification may result in considering the bid as non-responsive.
 - B. As needed a completed Suspension and Debarment Certification form will be required to be submitted by the prime contractor prior to contract execution.
 - C. Prime contractors must document they have verified that all subcontractors, vendors, suppliers and manufacturers are not debarred or excluded from participation in Federal assistance programs.
 1. Record of documentation of verification must be maintained throughout the duration of the project and available for review upon request by the Owner or Colorado SRF program.
 2. Upon completion of the project, the documentation must be provided to the Owner and maintained for at least three years after project completion.

Section 4 Equal Employment Opportunity

- I. Equal Opportunity Employment and Affirmative Action and Affirmative Action Requirements on Federally Assisted Construction Contracts: Notice and Equal Opportunity Clause

- A. NOTICE OF REQUIREMENT FOR AFFIRMATIVE ACTION TO ENSURE EQUAL EMPLOYMENT OPPORTUNITY (EXECUTIVE ORDER 11246)

This notice shall be included in, and shall be a part of, all solicitations for offers and bids on all federal and federally assisted construction contracts or subcontracts.

- (1) The Offerer's or Bidder's attention is called to the "Equal Opportunity Clause" and the "Standard Federal Equal Employment Specifications" set forth herein.
- (2) The goals and timetables for minority and female participation, expressed in percentage terms for the Contractor's aggregate workforce in each trade on all construction work in the covered area, are as follows:

County	Minority Participation in Each Trade ¹	Female Participation in Each Trade ¹
Fort Collins, Larimer	6.9%	6.9%
Archuleta, Delta, Dolores, Eagle, Garfield, Grand Junction, Gunnison, Hinsdale, Jackson, La Plata, Mesa, Moffat, Montezuma, Montrose, Ouray, Pitkin, Rio Blanco, Routt, San Juan, San Miguel	10.2%	6.9%
Colorado Springs, El Paso, Teller	10.9%	6.9%
Chaffee, Cheyenne, Clear Creek, Grand, Elbert, Kit Cason, Logan, Morgan, Park, Phillips, Sedgwick, Summit, Washington, Yuma	12.8%	6.9%
Greeley, Weld	13.1%	6.9%
Adams, Arapahoe, Boulder, Broomfield, Denver, Douglas, Gilpin, Jefferson	13.8%	6.9%
Alamosa, Baca, Bent, Conejos, Costilla, Crowley, Custer, Fremont, Huerfano, Kiowa, Lake, Las Animas, Lincoln, Mineral, Otero, Prowers, Rio Grande, Saguache	19.0%	6.9%

Pueblo	27.5%	6.9%
--------	-------	------

1) Source: FR Vol.45 No. 194 / Friday, October 3, 1980

These goals are applicable to all the contractor's construction work (whether or not it is Federal or Federally assisted) performed in the covered area. If the contractor performs construction work in a geographical area located outside of the covered area, it shall apply the goals established for such geographical area where the work is actually performed. With regard to this second area, the contractor also is subject to the goals for both its federally involved and non-federally involved construction.

The Contractor's compliance with the Executive Order and the regulations in 41 CFR Part 60-4 shall be based on its implementation of the Equal Opportunity Clause, specific affirmative action obligations required by the specifications set forth in 41 CFR 60-4.3(a), and its efforts to meet the goals. The hours of minority and female employment and training must be substantially uniform throughout the length of the contract, and in each trade, and the contractor shall make a good faith effort to employ minorities and women evenly on each of its projects. The transfer of minority or female employees or trainees from contractor to contractor or from project to project for the sole purpose of meeting the contractor's goals shall be a violation of the contract, the Executive Order, and the regulations in 41 CFR Part 60-4. Compliance with the goals will be measured against the total work hours performed.

- (3) The contractor shall provide written notification to the Director of the Office of Federal Contract Compliance Programs within 10 working days of award of any construction subcontract in excess of \$10,000 at any tier for construction work under the contract resulting from this solicitation. The notification shall list the name, address and telephone number for the subcontractor; employer identification number of the subcontractor; estimated dollar amount of the subcontract; estimated starting and completion dates of the subcontract; and the geographical area in which the contract is to be performed (See Form C).
- (4) As used in this Notice, and in the contract resulting from this solicitation, the covered area is County.

B. EQUAL OPPORTUNITY CLAUSES

- (1) The Equal Opportunity Clause published at 41 CFR Part 60-1.4(b) is required to be included in, and is part of, all nonexempt federally assisted construction contracts and subcontracts. By operation of the order, the equal opportunity clause shall be considered to be a part of every contract and subcontract required by the order and the regulations in this part to include such a clause whether or not it is physically incorporated.
- (2) In addition to the clauses described above, all federal contracting officers, all applicants, and all non-construction contractors, as applicable, shall include the specifications set forth in this section in all federal and federally assisted construction contracts in excess of \$10,000 to be performed in geographical areas designated by the Director pursuant to 41 CFR 60-4.6 of this part and in construction subcontracts in excess of \$10,000 necessary in whole or in part to the performance of non-construction Federal contracts and subcontracts covered under the Executive Order.

II. STANDARD FEDERAL EQUAL EMPLOYMENT OPPORTUNITY CONSTRUCTION CONTRACT SPECIFICATIONS (EXECUTIVE ORDER 11246)

A. DEFINITIONS AS USED IN SPECIFICATIONS

- (1) "Covered Area" means the geographical area described in solicitation from which this contract resulted;
- (2) "Director" means Director, Office of Federal Contract Compliance Programs, United States Department of Labor, or any person to whom the Director delegates authority;
- (3) "Employer identification number" means the Federal Social Security number used on the employer's quarterly Federal Tax Return, U.S. Treasury Department Form 941.
- (4) "Minority" includes:
 - (a) Black (all persons having origins in any of the Black African racial groups not of Hispanic origin);
 - (b) Hispanic (all persons of Mexican, Puerto Rican, Cuban, Central or South American or other Spanish Culture or origin, regardless of race);
 - (c) Asian and Pacific Islander (all persons having origins in any of the original peoples of the Far East, Southeast Asian, the Indian Subcontinent, or the Pacific Islands);
 - (d) American Indian or Alaskan Native (all persons having origins in any of the original peoples of North American and maintaining identifiable tribal affiliations through membership and participation or community identification).

B. DETAILED SPECIFICATIONS

- (1) Whenever the contractor, or any subcontractor at any tier, subcontracts a portion of the work involving any construction trade, it shall physically include in each subcontract in excess of \$25,000 the provisions of these specifications and the Notice which contains the applicable goals for minority and female participation and which is set forth in the solicitations from which this contract resulted.
- (2) If the contractor is participating (pursuant to 41 CFR 60-4.5) in a Hometown Plan (Plan) approved by the U.S. Department of Labor in the covered area either individually or through an association, its affirmative action obligations on all work in the Plan area, (including goals and timetables) shall be in accordance with that Plan for those trades which have unions participating in the Plan. Contractors must be able to demonstrate their participation in and compliance with the provisions of any such Hometown Plan. Each contractor or subcontractor participating in an approved Plan is individually required to comply with its obligations under the Equal Employment Opportunity (EEO) clause, and to make a good faith effort to achieve each goal under the Plan in each trade in which it has employees. The overall good faith performance by other contractors or subcontractors toward a goal in an approved Plan does not excuse any covered contractor's or subcontractor's failure to take good faith efforts to achieve the Plan goals and timetables.
- (3) The contractor shall implement the specific affirmative action standards provided in paragraphs (6)(a) through (p) of these specifications. The goals set forth in the solicitation from which this contract resulted are expressed as percentages of the total hours of employment and training of minority and female utilization the contractor should reasonably be able to achieve in each construction trade in which it has employees in the covered area. The contractor is expected to make substantially uniform progress toward its goals in each craft during the period specified.

- (4) Neither the provisions of any collective bargaining agreement, nor the failure by a union with whom the contractor has a collective bargaining agreement to refer either minorities or women shall excuse the contractor's obligations under these specifications, Executive Order 11246, or the regulations promulgated pursuant thereto.
- (5) In order for the non-working training hours of apprentices and trainees to be counted in meeting the goals, such apprentices and trainees must be employed by the contractor during the training period, and the contractor must have made a commitment to employ the apprentices and trainees at the completion of their training, subject to the availability of employment opportunities. Trainees must be trained pursuant to training programs approved by the U.S. Department of Labor.
- (6) The contractor shall take specific affirmative action to ensure equal employment opportunity. The evaluation of the contractor's compliance with these specifications shall be based upon its effort to achieve maximum results from its actions. The contractor shall document these efforts fully, and shall implement affirmative action steps at least as extensive as the following:
 - (a) Ensure and maintain a working environment free of harassment, intimidation, and coercion at all sites, and in all facilities at which the contractor's employees are assigned to work. The contractor, where possible, will assign two or more women to each construction project. The contractor shall specifically ensure that all foremen, superintendents, and other on-site supervisory personnel are aware of and carry out the contractor's obligation to maintain such a working environment, with specific attention to minority or female individuals working at such sites or in such facilities.
 - (b) Establish and maintain a current list of minority and female recruitment sources, provide written notification to minority and female recruitment sources and to community organizations where the contractor or its unions have employment opportunities available, and maintain a record of the organization's responses.
 - (c) Maintain a current file of the names, addresses, and telephone numbers of each minority and female off-the-street applicant and minority or female referral from a union, a recruitment source or community organization and of what action was taken with respect to each such individual. If such individual was sent to the union hiring hall for referral and was not referred back to the contractor by the union or, if referred, not employed by the contractor, this shall be documented in the file with the reason therefore, along with whatever additional actions the contractor may have taken.
 - (d) Provide immediate written notification to the Director when the union or unions with which the Contractor has a collective bargaining agreement has not referred to the Contractor a minority person or woman sent by the Contractor, or when the Contractor has other information that the union referral process has impeded the Contractor's efforts to meet its obligations.
 - (e) Develop on-the-job training opportunities and/or participate in training programs for the areas which expressly include minorities and women, including upgrading programs and apprenticeship and trainee programs relevant to the contractor's employment needs, especially those programs funded or approved by the Department of Labor. The contractor shall provide notice of these programs to the sources compiled under (7)(b) above.

- (f) Disseminate the contractor's EEO policy by providing notice of the policy to unions and training programs and requesting their cooperation in assisting the contractor in meeting its EEO obligations; by including it in any policy manual and collective bargaining agreement; by publicizing it in the company newspaper, annual report, etc.; by specific review of the policy with all management personnel and with all minority and female employees at least once a year; and by posting the company EEO policy on bulletin boards accessible to all employees at each location where construction work is performed.
- (g) Review, at least annually, the company's EEO policy and affirmative action obligations under these specifications with all employees having any responsibility for hiring, assignment, layoff, termination or other employment decisions including specific review of these items with on-site supervisory personnel such as superintendents, general foremen, etc., prior to the initiation of construction work at any job site. A written record shall be made and maintained identifying the time and place of these meetings, persons attending, subject matter discussed, and disposition of the subject matter.
- (h) Disseminate the contractor's EEO policy externally by including it in any advertising in the news media, specifically including minority and female news media, and providing written notification to and discussing the contractor's EEO policy with other contractors and subcontractors with whom the contractor does or anticipates doing business.
- (i) Direct its recruitment efforts, both oral and written, to minority, female and community organizations, to schools with minority and female students and to minority and female recruitment and training organizations servicing the contractor's recruitment area and employment needs. Not later than one month prior to the date for the acceptance of applications for apprenticeship or other training by any recruitment source, the contractor shall send written notification to organizations such as the above, describing the openings, screening procedures, and tests to be used in the selection process.
- (j) Encourage present minority and female employees to recruit other minority persons and women and, where reasonable, provide after school, summer and vacation employment to minority and female youth both on the site and in other areas of a contractor's workforce.
- (k) Validate all tests and other selection requirements where there is an obligation to do so under 41 CFR Part 60-3.
- (l) Conduct, at least annually, an inventory and evaluation at least of all minority and female personnel for promotional opportunities and encourage these employees to seek or to prepare for, through appropriate training, etc., such opportunities.
- (m) Ensure that seniority practices, job classification, work assignments and other personnel practices, do not have a discriminatory effect by continually

monitoring all personnel and employment related activities to ensure that the EEO policy and the contractor's obligations are followed.

- (n) Ensure that all facilities and company activities are non-segregated except that separate or single-user toilet and necessary changing facilities shall be provided to assure privacy between the sexes.
 - (o) Document and maintain a record of all solicitations of offers for subcontracts from minority and female construction contractors and suppliers, including circulation of solicitations to minority and female contractor associations and other business associations.
 - (p) Conduct a review, at least annually, of all supervisor's adherence to and performance under the contractor's EEO policies and affirmative action obligations.
- (7) Contractors are encouraged to participate in voluntary associations which assist in fulfilling one or more of their affirmative action obligations (6)(a) through (p). The efforts of a contractor association, joint contractor-union, contractor-community, or other similar group of which the contractor is a member and participant, may be asserted as fulfilling any one or more of its obligations under (6)(a) through (p) of the specifications provided that the contractor actively participates in the group, makes every effort to assure that the group has a positive impact on the employment of minorities and women in the industry, ensures that the concrete benefits of the program are reflected in the contractor's minority and female workforce participation, makes a good faith effort to meet its individual goals and timetables, and can provide access to documentation which demonstrates the effectiveness of actions taken on behalf of the contractor. The obligation to comply, however, is the contractor's and failure of such a group to fulfill an obligation shall not be a defense for the contractor's noncompliance.
- (8) A single goal for minorities and a separate single goal for women have been established. The contractor, however, is required to provide equal employment opportunity and to take affirmative action for all minority groups, both male and female, and all women, both minority and non-minority. Consequently, the contractor may be in violation of the Executive Order if a particular group is employed in a substantially disparate manner (for example, even though the contractor has achieved its goals for women generally, the contractor may be in violation of the order if a specific minority group of women is under-utilized).
- (9) The contractor shall not use the goals and timetables of affirmative action standards to discriminate against any person because of race, color, religion, sex, or national origin.
- (10) The contractor shall not enter into any subcontract with any person or firm debarred from government contracts pursuant to Executive Order 11246.
- (11) The contractor shall carry out such sanctions and penalties for violation of these specifications and of the Equal Opportunity Clause, including suspension, termination and cancellation of existing subcontracts as may be imposed or ordered pursuant to Executive Order 11246, as amended, and its implementing regulations, by the Office of Federal Contract Compliance Programs. Any contractor who fails to carry out such sanctions and penalties shall be in violation of these specifications and Executive Order 11246, as amended.
- (12) The contractor, in fulfilling its obligations under these specifications, shall implement specific affirmative action steps, at least as extensive as those standards prescribed in paragraph (6)

of these specifications, so as to achieve maximum results from its efforts to ensure equal employment opportunity. If the contractor fails to comply with the requirements of the Executive Order, the implementing regulations, or these specifications, the Director shall proceed in accordance with 41 CFR 60-4.3.

- (13) The contractor shall designate a responsible official to monitor all employment related activity to ensure that the company EEO policy is being carried out, to submit reports relating to the provisions hereof as may be required by the government and to keep records. Records shall at least include for each employee the name, address, telephone numbers, construction trade, union affiliation if any, employee identification number when assigned, social security number, race, sex, status (e.g., mechanic, apprentice, trainee, helper, or laborer), dates of changes in status, hours worked per week in the indicated trade, rate of pay, and locations at which the work was performed. Records shall be maintained in an easily understandable and retrievable form; however, to the degree that existing records satisfy this requirement, contractors shall not be required to maintain separate records.
- (14) Nothing herein provided shall be construed as a limitation upon the application of other laws which establish different standards of compliance or upon the application of requirements for the hiring of local or other area residents (e.g., those under the Public Works Employment Act of 1977 and the Community Development Block Grant Program).

Section 5

Williams-Steiger Occupational Safety and Health Act of 1970

A. Authority

- (1) The contractor is subject to the provisions of the Williams-Steiger Occupational Safety and Health Act of 1970.
- (2) These construction documents and the joint and several phases of construction hereby contemplated are to be governed, at all times, by applicable provisions of the Federal law(s), including but not limited to the latest amendment of the following:
 - (a) Williams-Steiger Occupational Safety and Health Act of 1970, Public Law 94-596;
 - (b) art 1910 - Occupational Safety and Health Standards, Chapter XVII of Title 29, Code of Federal Regulations;
 - (c) Part 1926 - Safety and Health Regulations for Construction, Chapter XVII of Title 29, Code of Federal Regulations.

B. Safety and Health Program Requirements

- (1) This project, its prime contractor and its subcontractors, shall at all times be governed by Chapter XVII of Title 29, Code of Federal Regulations, Part 1926 - Safety and Health Regulations for Construction (29 CFR 22801), as amended to date.
- (2) To implement the program and to provide safe and healthful working conditions for all persons, general project safety meetings will be conducted at the site at least once each month during the course of construction, by the construction superintendent or his/her designated safety officer. Notice of such meeting shall be issued not less than three (3) days prior, stating the exact time, location, and agenda to be included. Attendance by the owner, architect, general foreman, shop steward(s), and trades, or their designated representatives, witnessed in writing as such, shall be mandatory.
- (3) To further implement the program, each trade shall conduct a short gang meeting, not less than once a week, to review project safety requirements mandatory for all persons during the coming week. The gang foreman shall report the agenda and specific items covered to the project superintendent, who shall incorporate these items in his/her daily log or report.
- (4) The prime contractor and all subcontractors shall immediately report all accidents, injuries, or health hazards to the owner and architect, or their designated representatives, in writing. This shall not obviate any mandatory reporting under the provisions of the Occupational Safety and Health Act of 1970.
- (5) This program shall become a part of the contract documents and the contract between the owner and prime contractor, prime contractor and all subcontractors, as though fully written therein.

Section 6

Discovery of Archaeological and Other Historical Items

A. Construction Procedures

In the event of an archaeological or more recent historical find (e.g., artifacts, housing sites) during any phase of construction, the following procedure should be followed:

- (1) Construction shall be halted, with as little disruption to the archaeological site possible.
- (2) The Contractor shall notify the Owner who shall contact the State Historical Preservation Officer.
- (3) The State Historical Preservation Officer may decide to have an archaeologist inspect the site and make recommendations about the steps needed to protect the site, before construction is resumed.
- (4) The entire event should be handled as expediently as possible in order to hold the loss in construction time to a minimum while still protecting archaeological finds.

B. National Register Status

In the event archaeological/historical data are evaluated to meet National Register criteria, the Advisory Council on Historic Preservation may be notified and asked to comment by the Water Quality Control Division.

Section 7

Disadvantaged Business Enterprise (DBE) - SRF Program Grant Agreement Information and Requirements

OVERVIEW OF DISADVANTAGED BUSINESS ENTERPRISE (DBE) UTILIZATION

The Environmental Protection Agency's (EPA) new Disadvantaged Business Enterprise (DBE) rule became effective on May 27, 2008. The new DBE rule sets forth an EPA program that serves the compelling government interest of remedying past and current racial discrimination through agency-wide procurement objectives. The new DBE rule revises and replaces EPA's Minority and Women Business Enterprise (MBE/WBE) Program for funding received after May 27, 2008.

Note that the loan recipient is not a passive conduit of the contractor's DBE information. By submitting the proposed contractor's DBE documentation to the SRF Loan Program for review, the loan recipient is asserting that it has found the proposed contractor's documentation of good faith efforts adequate.

In order to be counted as a MBE/WBE under the new EPA DBE rule, MBE/WBEs must be certified by a federal agency (e.g., EPA, Small Business Administration, and Department of Transportation) or by a State, locality, Indian Tribe, or independent private organization that meets the certification requirements of the new EPA DBE rule. Under the new EPA DBE rule an individual claiming economic disadvantaged status must have an initial and continued personal net worth of less than \$750,000.

Locating potential DBE subcontractors is the responsibility of the bidder/contractor. The following is a list of resources that may be used to locate potential DBEs:

- The Colorado Department of Transportation maintains a listing of certified DBEs on its website at: [Colorado Unified Certification Program \(dbesystem.com\)](http://colorado.unifiedcertification.com)
- The EPA Office of Small and Disadvantaged Business Utilization provides a small business vendor database that may include certified DBEs at: <https://vpmdsweb.epa.gov/Vendors/list>
- The Small Business Association (SBA) provides a small business procurement database search that includes the ability to search for certified DBEs at: <https://www.sba.gov/partners/contracting-officials/small-business-procurement>

Applications for certification by EPA can be found on EPA's Small Business Programs website at http://www.epa.gov/osbp/dbe_fair.htm Attention is hereby called to the services of the Small Business Association (SBA) and the Minority Business Development Agency (MBDA) of the Department of Commerce that can assist DBEs.

Each procurement contract signed by a loan participant must include the following term and condition:

"The contractor shall not discriminate on the basis of race, color, national origin or sex in the performance of this contract. The contractor shall carry out applicable requirements of 40 CFR part 33 in the award and administration of contracts awarded under EPA financial assistance agreements. Failure by the contractor to carry out these requirements is a material breach of this contract which may result in the termination of this contract or other legally available remedies." (Appendix A to Part 33—Term and Condition)

Additionally, the above term and condition is considered included in the contract in which this specification forms a part of the contract documents.

GUIDANCE FOR UTILIZATION OF DISADVANTAGED BUSINESS ENTERPRISES REQUIREMENTS OF 40 CFR PART 33

A. REQUIREMENTS

1. Each procurement contract signed by a loan recipient must include the following term and condition:

The contractor shall not discriminate on the basis of race, color, national origin or sex in the performance of this contract. The contractor shall carry out applicable requirements of 40 CFR 33 in the award and administration of contracts awarded under EPA financial assistance agreements. Failure by the contractor to carry out these requirements is a material breach of this contract which may result in the termination of this contract or other legally available remedies.

2. The recipient and prime contractor will create and maintain a bidders list if the recipient of the loan is subject to, or chooses to follow, competitive bidding requirements. The purpose of a bidders list is to provide the recipient and entities receiving identified loans who conduct competitive bidding with as accurate a database as possible about the universe of MBE/WBE and non-MBE/WBE prime and subcontractors. The list must include all firms that bid or quote on prime contracts, or bid or quote subcontracts on EPA assisted projects, including both MBE/WBEs and non-MBE/WBEs. The bidders list must only be kept until the project period for the identified loan has ended. The following information must be obtained from all prime and subcontractors:

- (a) Entity's name with point of contact;
- (b) Entity's mailing address, telephone number, and e-mail address;
- (c) The procurement on which the entity bid or quoted, and when; and
- (d) Entity's status as an MBE/WBE or non-MBE/WBE.

3. The recipient and prime contractor will exercise good faith efforts to attract and utilize small, minority, and women's business enterprises primarily through outreach, recruitment, and race/gender neutral activities.

- (a) At a minimum, fulfillment of six affirmative steps (good faith efforts) is required as set forth below:

1. Ensure DBEs are made aware of contracting opportunities to the fullest extent practicable through outreach and recruitment activities. For Indian, Tribal, State and Local and Government recipients, this will include placing DBEs on solicitation lists and soliciting them whenever they are potential sources.
2. Make information on forthcoming opportunities available to DBEs and arrange time frames for contracts and establish delivery schedules, where the requirements permit, in a way that encourages and facilitates participation by DBEs in the competitive process. This includes, whenever possible, posting solicitations for bids or proposals for a minimum of 30 calendar days before the bid or proposal closing date.
3. Consider in the contracting process whether firms competing for large contracts could subcontract with DBEs. For Indian, Tribal, State and local Government recipients, this will include dividing total requirements when economically feasible into smaller tasks or quantities to permit maximum participation by DBEs in the competitive process.
4. Encourage contracting with a consortium of DBEs when a contract is too large for one of these firms to handle individually.

5. Use the services of the Small Business Association ([SBA](#)) and the Minority Business Development Agency ([MBDA](#)) of the Department of Commerce.
 6. If the prime contractor awards subcontract, require the prime contractor to take the affirmative Steps 1 through 5 listed above.
4. The prime contractor must pay its subcontractors for satisfactory performance no more than 30 days from the prime contractor's receipt of payment from the owner.
 5. The prime contractor must notify the owner in writing prior to any termination of a DBE subcontractor for convenience.
 6. If a DBE subcontractor fails to complete work under the subcontract for any reason, the prime contractor must employ the good faith efforts if soliciting a replacement subcontractor, even if the fair share objectives have already been achieved.

B. FAIR SHARE OBJECTIVES

1. The Colorado SRF project goals are:

SRF Project	%MBE	%WBE
Construction	6.1%	6.6%

C. DEFINITIONS

1. Disadvantaged Business Enterprise (DBE) is a business concern which meets the qualifications of a Minority Business Enterprise (MBE), Women's Business Enterprise (WBE)
2. Minority Business Enterprise (MBE) is a business concern which is:
 - (a) Certified as socially and economically disadvantaged by the Small Business Administration;
 - i. Socially disadvantaged individuals are those who have been subjected to racial or ethnic prejudice or cultural bias because of their identity as a member of a group without regard to their individual qualities.
 - ii. Economically disadvantaged individuals are those socially disadvantaged individuals whose ability to compete in the free enterprise system is impaired due to diminished capital and credit opportunities, as compared to others in the same business area who are not socially disadvantaged. In determining the degree of diminished credit and capital opportunities, the Small Business Administration shall consider, but not be limited to, the assets and net worth of such socially disadvantaged individuals. Individuals who certify that they are members of named groups (Black Americans, Hispanic Americans, Native Americans, Asian-Pacific Americans, Asian-Indian Americans), are to be

considered socially and economically disadvantaged. Economically and socially disadvantaged individuals are deemed to include women.

- (b) Certified as a minority business enterprise by a State or Federal agency; and
- (c) An independent business concern which is at least 51 percent owned and controlled by minority group member(s).
 - i. A minority group member is an individual who is a citizen of the United States and one of the following:
 - 1. Black American;
 - 2. Hispanic American (with origins from Puerto Rico, Mexico, Cuba, South or Central America)
 - 3. Native American (American Indian, Eskimo, Aleut, native Hawaiian); or
 - 4. Asian-Pacific American (with origins from Japan, China, the Philippines, Vietnam, Korea, Samoa, Guam, the U.S. Trust Territories of the Pacific, Northern Marianas, Laos, Cambodia, Taiwan or the Indian subcontinent).
 - ii. In order to satisfy this third criteria of the MBE definition, the minority ownership's interest must be real, substantial and continuing. Such interest is characterized by:
 - 1. Risk of loss/share of profit commensurate with the proportional ownership; and
 - 2. Receipt of the customary incidents of ownership, such as compensation (i.e., salary and other personnel compensation).
 - iii. A minority owner must have and exercise control of the business decisions. Characteristics of control include, but are not limited to:
 - 1. Authority to sign bids and contracts;
 - 2. Decisions in price negotiations;
 - 3. Incurring liabilities for the firm;
 - 4. Final staffing decisions;
 - 5. Policy-making; and
 - 6. General company management decisions.
 - iv. Only those firms performing a useful business function according to custom and practice in the industry, are qualified as MBEs. Acting merely as a passive conduit of funds to some other firm where such activity is unnecessary to accomplish the project does not constitute a "useful business function according to custom and practice in the industry." The purpose of this approach is to discourage the use of MBE "fronts" and limit the creation of an artificial supplier and broker marketplace.

3. Women's Business Enterprise (WBE) is a business which is certified as such by a State or Federal agency, or which meets the following definition:

"A women's business enterprise is an independent business concern which is at least 51 percent owned by a woman or women, who also control and operate it. Determination of whether a business is at least 51 percent owned by a woman or otherwise qualified WBE which is 51 percent owned by a married woman in a community property State will not be disqualified because her husband has a 50 percent interest in her share. Similarly, a business which is 51 percent owned by a married man and 49 percent owned by an unmarried woman will not become a qualified WBE by virtue of his wife's 50 percent interest in his share of the business."

As in the case of a MBE, only United States citizens will be deemed to be WBEs. Similar to the MBE criteria, WBE should meet the criteria cited in subparagraphs C.2.a., C.2.b, and C.2.c(2), (3), and (4).

4. Fair Share or Fair Share Objective: A fair share or a fair share objective is an amount of funds reasonably commensurate with the total project funding and the availability of qualified MBEs and WBEs, taking into account experience on EPA-funded projects and other comparable projects in the area. A fair share objective does not constitute an absolute requirement, but a commitment on the part of the bidder to exercise good faith efforts as defined in this section to use MBEs and WBEs to achieve the fair share objective.
5. Recipient: A party receiving SRF financial assistance.
6. Project: The scope of work for which an SRF loan is awarded.
7. Bidder: A party seeking to obtain a contract with a recipient through a competitive, advertised, sealed bid process.
8. Offeror: A party seeking to obtain a contract with a recipient through a negotiative procurement process.
9. Prime Contractor: A party that has obtained a contract with a recipient through a competitive, advertised, sealed bid process.
10. Good Faith Efforts: Good faith efforts by a recipient, prime contractor, and/or bidder/offeror means efforts to attract and utilize DBEs primarily through outreach, recruitment, and race/gender neutral activities. The following are examples of activities to assist recipients, prime contractors and/or bidders/offerors to comply with good faith efforts.
 - (a) Ensure DBEs are made aware of contracting opportunities to the fullest extent practicable through outreach and recruitment activities. For Indian, Tribal, State and Local and Government recipients, this will include placing DBEs on solicitation lists and soliciting them whenever they are potential sources.
 - i. Maintain and update a listing of qualified MBE/WBEs that can be solicited for construction, equipment, services and/or supplies.

- ii. Provide listings to all interested parties who request copies of the bidding or proposing documents.
 - iii. Contact appropriate sources within your geographic area and state to identify qualified MBE/WBE for placement on your MBE/WBE business listings.
 - iv. Utilize other MBE/WBE listings such as those of the state's minority business office, the Small Business administration ([SBA](#)), Minority Business Development Agency ([MBDA](#)) of the Department of Commerce, EPA OSDDBU, and DOT.
 - v. Have state environment agency personnel review solicitation lists.
- (b) Make information on forthcoming opportunities available to DBEs and arrange time frames for contracts and establish delivery schedules, where the requirements permit, in a way that encourages and facilitates participation by DBEs in the competitive process. This includes, whenever possible, posting solicitations for bids or proposals for a minimum of 30 calendar days before the bid or proposal closing date.
- i. Develop realistic delivery schedules which may provide for greater MBE/WBE participation.
 - ii. Advertise through the minority media in order to facilitate MBE/WBE utilization. Such advertisements may include, but are not limited to, contracting and subcontracting opportunities, hiring and employment, or any other matter related to the project.
 - iii. Advertise in general circulation publications, trade publications, state agency publications and minority and women's business focused media concerning contracting opportunities on your projects. Maintain a list of minority and/or women's business-focused publications that may be utilized to solicit MBE/WBEs.
- (c) Consider in the contracting process whether firms competing for large contracts could subcontract with DBEs. For Indian, Tribal, State and local Government recipients, this will include dividing total requirements when economically feasible into smaller tasks or quantities to permit maximum participation by DBEs in the competitive process.
- i. Perform an analysis to identify portions of work that can be divided and performed by qualified MBE/WBEs.
 - ii. Scrutinize the elements of the total project to develop economical units of work that are within the bonding range of MBE/WBEs.
 - iii. Conduct meetings, conferences, and follow-ups with MBE/WBE associations and minority media to inform these groups of opportunities to provide construction, equipment, services and supplies.
- (d) Encourage contracting with a consortium of DBEs when a contract is too large for one of these firms to handle individually.

- i. Notify MBE/WBEs of future procurement opportunities so they may establish bidding solicitations and procurement plans.
 - ii. Provide MBE/WBE trade organizations with succinct summaries of solicitations.
 - iii. Provide interested MBE/WBEs with adequate information about plans, specifications, timing and other requirements of the proposed projects.
- (e) Use the services of the [SBA](#) and the Minority Business Development Agency ([MBDA](#)) of the Department of Commerce.
- i. Use the services of outreach programs sponsored by the MBDA and/or the SBA to recruit bona fide firms for placement on DBE bidders lists to assist these firms in the development of bid packaging.
 - ii. Seek out Minority Business Development Centers (MBDC) to assist recipients and prime contractors in identifying MBE/WBEs for potential work opportunities on projects.
- (f) If the prime contract awards subcontracts, require the prime contractor to take steps in Paragraphs (a) through (e) of this section.

D. **REPORTING**

During Bidding:

1. Bidders/offerors must demonstrate compliance with good faith efforts in order to be deemed responsible.
2. The prime contractor must complete DBE Solicitations Form (**Form 6100-4**).
3. The prime contractor must have its DBE subcontractors complete DBE Program Subcontractor Performance Form (**Form 6100-3**).
4. **Form 6100-3** and **Form 6100-4** must be submitted by all bidders with their bid. Failure to submit this information may result in the bid being considered as a non-responsive bid.

During Performance of the Contract:

5. The prime contractor must distribute DBE Program Subcontractor Participation Form (**Form 6100-2**) to all of its contracted DBE subcontractors. The subcontractors can submit completed forms to the State of Colorado, Water Quality Control Division, Grants and Loans Unit.
6. The prime contractor must complete **DBE Form B** to report DBE procurements made during each quarter. These reports must be submitted within 5 days of the end of each Federal fiscal quarter (by 1/5, 4/5, 7/5, and 10/5). Reports may be emailed to: CDPHE_grantsandloans@state.co.us
The recipient will in turn submit this reporting for “DBE Utilization Under Federal Grants, Cooperative Agreements, and Interagency Agreements,” to the Project Administrator beginning with the Federal Fiscal year quarter the bid is awarded and continuing until the project is completed.

Section 8

Prohibition on Certain Telecommunication and Video Surveillance Services or Equipment

The following requirements including terms and conditions apply to this contract and expenditures submitted for reimbursement through the state revolving fund loan covering the work to be completed in this contract.

- A. This term and condition implements 2 CFR 200.216 and is effective for obligations and expenditures of EPA financial assistance funding on or after 8/13/2020.
- B. As required by 2 CFR 200.216, EPA recipients and subrecipients, including borrowers under EPA funded revolving loan fund programs, are prohibited from obligating or expending loan or grant funds to procure or obtain; extend or renew a contract to procure or obtain; or enter into a contract (or extend or renew a contract) to procure or obtain equipment, services, or systems that use covered telecommunications equipment or services as a substantial or essential component of any system, or as critical technology as part of any system. As described in [Public Law 115-232](#), section 889, covered telecommunications equipment is telecommunications equipment produced by Huawei Technologies Company or ZTE Corporation (or any subsidiary or affiliate of such entities). Recipients, subrecipients, and borrowers also may not use EPA funds to purchase:
 1. For the purpose of public safety, security of government facilities, physical security surveillance of critical infrastructure, and other national security purposes, video surveillance and telecommunications equipment produced by Hytera Communications Corporation, Hangzhou Hikvision Digital Technology Company, or Dahua Technology Company (or any subsidiary or affiliate of such entities).
 2. Telecommunications or video surveillance services provided by such entities or using such equipment.
 3. Telecommunications or video surveillance equipment or services produced or provided by an entity that the Secretary of Defense, in consultation with the Director of the National Intelligence or the Director of the Federal Bureau of Investigation, reasonably believes to be an entity owned or controlled by, or otherwise connected to, the government of a covered foreign country.
- C. Consistent with 2 CFR 200.471, costs incurred for telecommunications and video surveillance services or equipment such as phones, internet, video surveillance, and cloud servers are allowable except for the following circumstances:
 1. Obligating or expending EPA funds for covered telecommunications and video surveillance services or equipment or services as described in 2 CFR 200.216 to:
 - a) Procure or obtain, extend or renew a contract to procure or obtain;
 - b) Enter into a contract (or extend or renew a contract) to procure; or
 - c) Obtain the equipment, services, or systems.

2. Certain prohibited equipment, systems, or services, including equipment, systems, or services produced or provided by entities identified in section 889, are recorded in the System for Award Management exclusion list at <https://sam.gov/>
- D. There is no exhaustive list of components and services that fall under the prohibition. Exercise due diligence and be particularly mindful of project components with internet or cellular connections. For example, recipients should be mindful of automatic meter reading (AMR) technology and advanced metering infrastructure (AMI), instrumentation control systems (e.g. process control systems, distributed control systems and programmable logic controls), and security cameras and other electronic security measures to ensure that those items are procured from a non-excluded entity. Items included in the prohibition are not eligible SRF costs, and the SRF programs cannot reimburse borrowers for these costs.

Section 9

Signage Requirements

- A. Signage must be placed at construction sites in an easily visible location that can be directly linked to the work taking place and must be maintained in good condition throughout the construction period. In cases where the construction site covers a large area (e.g., lead service line replacement or septic tank repair/replacement projects), a sign should be placed in an easily visible location near where the work is being performed (e.g., entrance to the neighborhood, along a main road through town, etc.). Signage costs are considered an allowable SRF expense, provided the costs associated with the signage are reasonable. Additionally, to increase public awareness of projects serving communities where English is not the predominant language, assistance recipients are encouraged to translate the language on signs (excluding the official emblems or EPA logo or seal) into the appropriate non-English language(s). The costs of such translation are allowable SRF expenses, provided the costs are reasonable.
- B. The BIL signage term and condition requires a physical sign displaying required emblems and EPA logo be placed at construction sites for BIL-funded projects. The required emblems, styles, format, size, and detailed instructions for producing the required sign is included in the following guidance:
 1. [CO SRF Bipartisan Infrastructure Law Signage Guidance](#) and [SRF agency logo files](#)

Section 10

Build America, Buy America (BABA)

- A. The State Revolving Fund Program and the contract including this specification is subject to, and requires compliance with, the Build America, Buy America Act (BABA) requirements. The BABA requirements refer to Title IX-Build America, Buy America of the Infrastructure Investment and Jobs Act (IIJA) also known as the Bipartisan Infrastructure Law (BIL) passed by Congress on November 15, 2021.
- B. ALL CONSTRUCTION CONTRACTS MUST HAVE THE FOLLOWING CLAUSE REQUIRING COMPLIANCE WITH THE BABA REQUIREMENTS:
1. The Contractor acknowledges to and for the benefit of the Owner and the Funding Authority (Colorado Water Resources and Power Development Authority) that it understands the goods and services under the loan agreement for the project are being funded with federal monies and have statutory requirements commonly known as “Build America, Buy America;” that requires all of the iron and steel, manufactured products, and construction materials used in the project to be produced in the United States (“Build America, Buy America Requirements”) including iron and steel, manufactured products, and construction materials provided by the Contractor pursuant to this Agreement. The Contractor hereby represents and warrants to and for the benefit of the Owner and Funding Authority (a) the Contractor has reviewed and understands the Build America, Buy America Requirements, (b) all of the iron and steel, manufactured products, and construction materials used in the project will be and/or have been produced in the United States in a manner that complies with the Build America, Buy America Requirements, unless a waiver of the requirements is approved in writing for the project as described in this specification and (c) the Contractor will provide any further verified information, certification or assurance of compliance with this paragraph, or information necessary to support a waiver of the Build America, Buy America Requirements, as may be requested by the Owner or the Funding Authority. Notwithstanding any other provision of this Agreement, any failure to comply with this paragraph by the Contractor shall permit the Owner or Funding Authority to recover as damages against the Contractor any loss, expense, or cost (including without limitation attorney’s fees) incurred by the Owner or Funding Authority resulting from any such failure (including without limitation any impairment or loss of funding, whether in whole or in part, from the Funding Authority or any damages owed to the Funding Authority by the Owner). If the Contractor has no direct contractual privity with the Funding Authority, as a lender or awardee to the Owner for the funding of its project, the Owner and the Contractor agree that the Funding Authority is a third-party beneficiary and neither this paragraph (nor any other provision of this Agreement necessary to give this paragraph force or effect) shall be amended or waived without the prior written consent of the Funding Authority.
- C. In providing bids, proposals, or services, the Contractor represents and warrants to and for the benefit of the borrower and the State Revolving Fund the following:
1. The Contractor has reviewed and understands the Build America, Buy America Act Requirements.
 2. All of the iron and steel, manufactured products, and construction materials used in the project in the United States in a manner that complies with the Build America, Buy America Requirements, unless a waiver of the requirements has been approved in writing for the project as described in this specification .
- D. By signing payment applications and requesting payment, Contractor certifies they have reviewed documentation for all products and materials submitted for payment, and the certifications are sufficient to demonstrate compliance with Build America, Buy America Requirements.
- E. Build America, Buy America Products
1. Product Definitions

Title IX - Build America, Buy America of the Infrastructure Investment and Jobs Act (IIJA) also known as the Bipartisan Infrastructure Law (BIL) includes the following:

Title IX - Build America, Buy America, Subtitle A - Build America, Buy America, Part I - Buy America Sourcing Requirements, Section 70912 DEFINITIONS, (6) PRODUCED IN THE UNITED STATES.—The term “produced in the United States” means—

(A) in the case of iron or steel products, that all manufacturing processes, from the initial melting stage through the application of coatings, occurred in the United States;

(B) in the case of manufactured products, that—

(i) the manufactured product was manufactured in the United States; and

(ii) the cost of the components of the manufactured product that are mined, produced, or manufactured in the United States is greater than 55 percent of the total cost of all components of the manufactured product, unless another standard for determining the minimum amount of domestic content of the manufactured product has been established under applicable law or regulation; and

(C) in the case of construction materials, that all manufacturing processes for the construction material occurred in the United States.

2. Product Examples

The following is provided strictly as examples and it is the Contractor’s responsibility to ensure that all products comply with the BABA Requirements.

(a). Environmental Protection Agency (EPA) [Memorandum on Build America Act Implementation Procedures for the EPA Office of Water Federal Financial Assistance Programs dated November 3, 2023](#) provides the following guidance in Section 2: Product Coverage:

Q2.1: For products made of iron and steel, what is the difference between predominantly and primarily iron and steel?

A2.1: EPA considers the terms “predominantly” and “primarily” to be interchangeable, such that a product is considered predominantly (or primarily) iron and steel if it contains greater than 50 percent iron and steel by material cost.

Q2.2: What is the definition of construction materials (with examples)?

A2.2: From OMB Guidance M-22-11: “construction materials” include an article, material, or supply (other than an item of primarily iron or steel; a manufactured product; cement and cementitious materials; aggregates such as stone, sand, or gravel; aggregate binding agents or additives; or non-permanent products) that is or consists primarily of: non-ferrous metals, plastic and polymer-based products (including polyvinyl chloride, composite building materials, and polymers used in fiber optic cables), (including optic glass), lumber, and drywall.

Q2.3: What are manufactured products (with examples)?

A2.3: From OMB Guidance M-22-11: “...all manufactured products used in the project are produced in the United States—this means the manufactured product was manufactured in the United States; and the cost of the components of the manufactured product that are mined, produced, or manufactured in the United States is greater than 55 percent of the total cost of all components of the manufactured product, unless another standard for determining the minimum amount of domestic content of the manufactured product has been established under applicable law or regulation...” The manufactured products category would cover the majority of potential water infrastructure products, including complex products made up of a variety of material types and components. For water infrastructure projects, common manufactured products would include, but not be limited to, pumps, motors, blowers, aerators, generators, instrumentation and control systems, gauges, meters, measurement equipment, treatment equipment, dewatering equipment, actuators, and many other mechanical and electrical items.

(b) The EPA [Memorandum on Build America Act Implementation Procedures for the EPA Office of Water Federal Financial Assistance Programs dated November 3, 2023](#) provides example lists of products classified as Iron and Steel and Manufactured Products.

F. Waivers

1. Types of Waivers

Pursuant to Section 70914(c) of the BABA Act, EPA may waive Buy America preference where EPA finds that:

- a. Applying the domestic content procurement preference would be inconsistent with the public interest (a “public interest waiver”);
- b. Types of iron, steel, manufactured products, or construction materials are not produced in the United States in sufficient and reasonably available quantities or of a satisfactory quality (a “nonavailability waiver”); or
- c. Inclusion of iron, steel, manufactured products, or construction materials produced in the United States will increase the cost of the overall project by more than 25 percent (an “unreasonable cost waiver”).

2. Applying for a Waiver

a. EPA issued waivers

- i. A list of EPA issued waivers is available at the following site:

<https://www.epa.gov/cwsrf/build-america-buy-america-baba-approved-waivers>

- ii. The Owner and Contractor must submit a written request to the Colorado SRF program for approval of an EPA issued waiver.

- iii. A waiver is not approved until written approval has been issued by the Colorado SRF program or the EPA (if required by the waiver).

1. Exception: Use of the [Public Interest: DeMinimis General Applicability Waiver of Section 70914\(a\) of P.L. 117-58, Build America, Buy America Act, 2021 for US EPA Financial Assistance Awards and Procurements issued October 21, 2022](#) does not require prior approval; however the Owner and Contractor must submit written notification that the waiver will be used, and DeMinimis compliance documentation must be submitted as described in this specification to demonstrate compliance with the waiver.

b. Project specific waivers

- a. The Owner and Contractor must notify the state agency in writing prior to applying for a waiver. The assistance recipient should email the request in the form of a Word document (.doc) or editable PDF (.pdf) to the funding program. The state designee(s) will review the application for the waiver and determine whether the necessary information has been included.
- b. After receiving an application for a waiver, EPA will perform market research to determine whether the iron, steel, manufactured goods, or construction materials are available domestically, or whether the items are cost prohibitive.
- c. After research, if no domestic product has been identified, EPA is required to publish the application and all material submitted with the application on EPA's website for 15 days. During that period, the public will have the opportunity to review the request and provide informal comment to EPA. The website can be found at:
<https://www.epa.gov/cwsrf/build-america-buy-america-baba-waivers-open-public-comment>
- d. After receiving an application for waiver of the BABA requirements, EPA will determine whether the application properly and adequately documents and justifies the statutory basis cited for the waiver to determine whether or not to grant the waiver.
- e. Signature of waiver approval by the Administrator or another agency official with delegated authority - As soon as the waiver is signed and dated, EPA will notify the State

SRF program and post the signed waiver on the Agency's website. The assistance recipient should keep a copy of the signed waiver in its project files.

- f. A waiver is not approved until EPA has fully completed the approval process as described above and the Owner and Contractor must not rely on the waiver to meet the BABA requirements until the waiver is approved.

G. Compliance Documentation

1. Compliance with the BABA requirements is essential for the duration of the project. If a project is found to be out of compliance or fails to provide required documentation with the BABA requirements, funding may be withheld until the issue is rectified or other measures may be implemented as described herein.
 - a. Compliance is assessed where the domestic product is used (or installed) at the project site. Proper compliance documentation, whether it is a BABA certification letter or a waiver, should accompany a product prior to its "use", in accordance with Section 70914(a) of BIL.
 - b. Assistance recipients and their representatives should ensure that the products delivered to the construction site are accompanied by proper documentation that demonstrate compliance with the law and be made available to Colorado SRF program upon request. The documentation may be received and maintained in hard copy or electronically.
 - c. All BABA compliance documentation must be maintained by the contractor onsite for the duration of the project,
 - d. Upon completion of the project, the documentation must be provided to the Owner and maintained for at least three years after project completion.
2. Required Documentation
 - a. **BABA Product Certification Letters:** The contractor must collect certified letters for all products that fall underneath the BABA Requirements. At minimum the certification letter must include the following elements:
 1. Specific project reference
 2. Specific List of Products
 3. Location of Manufacturing (city and state)
 4. Signature of authorized manufacturer representative
 5. Reference to the Build America, Buy America Act and that the products comply with the BABA Requirements.

Note: For products that are considered "Iron or Steel" as defined in the BABA requirements a product certification letter including elements 1 through 4 listed above and certifying compliance with the EPA American Iron and Steel requirement are acceptable.
 - b. **SRF BABA Product Tracking Log:** The contractor must maintain a tracking log of all the products that must comply with the BABA Requirements categorizing each product as either an "Iron or Steel" product, a "Manufactured Product", or a "Construction Material" and the tracking log must document that a BABA certification has been collected for each product. The contractor must submit the tracking log with each pay application and it must be included in each reimbursement requisition submitted to the Colorado SRF program.
 1. The Colorado SRF Program will review the product log and request submission of BABA certification letters as needed during reimbursement requisition review to verify BABA Requirements compliance.
 - c. **SRF BABA Pay Application Certification Form:** The assistance recipient must sign and submit the form with each reimbursement requisition. Reimbursement requisitions will not be processed until the signed form is submitted and failure to submit the signed certification form may result in considering the project out of compliance with this specification and the BABA requirements.

Section 11

SRF Required Forms by Section

SRF forms can be found at the following website (click on “Forms” button at bottom of page):

<https://cdphe.colorado.gov/state-revolving-fund-information>

The list of forms are below. Please contact your SRF Project Manager if you have any questions.

Section 1 - Davis Bacon Prevailing Wages

- Davis Bacon Certification Form (SRF form);
- WH - 347 - Contractors Payroll Form;
- Standard Form 1444 - Request for Authorization of Additional Classification and Rate;
- Standard Form 1445 - Labor Standards Interview Form.

Section 2 - American Iron and Steel

- SRF American Iron and Steel Certification Form
- SRF American Iron and Steel Product Log

Section 3 - National Term on Suspension and Debarment

- Suspension and Debarment Certification

Section 4 - Equal Employment Opportunity and Affirmative Action Requirements

- No applicable forms.

Section 5 - Williams-Steiger Occupational Safety and Health Act of 1970

- No applicable forms.

Section 6 - Discovery of Archaeological and Other Historical Items

- No applicable forms.

Section 7 - Disadvantaged Business Enterprise (DBE)

- Form 6100-2 provided by prime contractor and completed by DBE subcontractor and submitted to the CDPHE GLU project manager.
- Form 6100-3 completed by prime contractor and DBE subcontractor and submitted to CDPHE GLU project manager as part of their bid.
- Form 6100-4 completed by prime contractor and submitted as part of their bid.
- DBE Form B completed by prime contractor submitted to cdphe_grantsandloans@state.co.us.

Section 8 - Prohibition on Certain Telecommunication and Video Surveillance Services or Equipment

- No applicable forms.

Section 9 - Signage Requirements

- No applicable forms, reference [CO SRF Bipartisan Infrastructure Law Signage Guidance](#) and [SRF agency logo files](#)

Section 10 - Build America, Buy America

- SRF BABA Product Tracking Log
- SRF BABA Pay Application Certification Form

"General Decision Number: C020240002 02/23/2024

Superseded General Decision Number: C020230002

State: Colorado

Construction Type: Heavy

Counties: Adams, Arapahoe, Boulder, Broomfield, Denver, Douglas, El Paso, Jefferson, Larimer, Mesa, Pueblo and Weld Counties in Colorado.

HEAVY CONSTRUCTION PROJECTS

Note: Contracts subject to the Davis-Bacon Act are generally required to pay at least the applicable minimum wage rate required under Executive Order 14026 or Executive Order 13658. Please note that these Executive Orders apply to covered contracts entered into by the federal government that are subject to the Davis-Bacon Act itself, but do not apply to contracts subject only to the Davis-Bacon Related Acts, including those set forth at 29 CFR 5.1(a)(1).

If the contract is entered into on or after January 30, 2022, or the contract is renewed or extended (e.g., an option is exercised) on or after January 30, 2022:	<ul style="list-style-type: none">. Executive Order 14026 generally applies to the contract.. The contractor must pay all covered workers at least \$17.20 per hour (or the applicable wage rate listed on this wage determination, if it is higher) for all hours spent performing on the contract in 2024.
If the contract was awarded on or between January 1, 2015 and January 29, 2022, and the contract is not renewed or extended on or after January 30, 2022:	<ul style="list-style-type: none">. Executive Order 13658 generally applies to the contract.. The contractor must pay all covered workers at least \$12.90 per hour (or the applicable wage rate listed on this wage determination, if it is higher) for all hours spent performing on that contract in 2024.

The applicable Executive Order minimum wage rate will be adjusted annually. If this contract is covered by one of the Executive Orders and a classification considered necessary for performance of work on the contract does not appear on this wage determination, the contractor must still submit a conformance request.

Additional information on contractor requirements and worker protections under the Executive Orders is available at <http://www.dol.gov/whd/govcontracts>.

Modification Number	Publication Date
0	01/05/2024
1	02/23/2024

* ASBE0028-001 01/01/2024

	Rates	Fringes
Asbestos Workers/Insulator (Includes application of all insulating materials, protective coverings, coatings and finishings to all types of mechanical systems).....	\$ 32.98	16.47

BRCO0007-004 01/01/2023

ADAMS, ARAPAHOE, BOULDER, BROOMFIELD, DENVER, DOUGLAS,
JEFFERSON AND WELD COUNTIES

	Rates	Fringes
BRICKLAYER.....	\$ 34.18	10.86

BRCO0007-006 05/01/2023

EL PASO AND PUEBLO COUNTIES

	Rates	Fringes
BRICKLAYER.....	\$ 31.89	13.70

ELEC0012-011 09/01/2023

PUEBLO COUNTY

	Rates	Fringes
ELECTRICIAN.....	\$ 31.90	14.96

 ELEC0068-001 06/01/2023

ADAMS, ARAPAHOE, BOULDER, BROOMFIELD, DENVER, DOUGLAS,
 JEFFERSON, LARIMER, AND WELD COUNTIES

	Rates	Fringes
ELECTRICIAN.....	\$ 43.20	18.38

 ELEC0111-001 09/01/2023

	Rates	Fringes
Line Construction:		
Groundman.....	\$ 24.61	21.25%+7.40
Line Equipment Operator.....	\$ 39.77	21.25%+7.40
Lineman and Welder.....	\$ 55.22	24.25%+7.40

 * ELEC0111-007 01/01/2023

MESA COUNTY

	Rates	Fringes
ELECTRICIAN.....	\$ 27.10	12.62

 ELEC0113-002 06/01/2023

EL PASO COUNTY

	Rates	Fringes
ELECTRICIAN.....	\$ 35.70	17.52

 ENGI0009-001 05/01/2023

	Rates	Fringes
Power equipment operators:		
Blade: Finish.....	\$ 34.58	14.25
Blade: Rough.....	\$ 34.05	14.25
Bulldozer.....	\$ 34.05	14.25
Cranes: 50 tons and under..	\$ 34.77	14.25
Cranes: 51 to 90 tons.....	\$ 35.07	14.25

Cranes: 91 to 140 tons.....	\$ 36.27	14.25
Cranes: 141 tons and over...	\$ 38.63	14.25
Forklift.....	\$ 33.62	14.25
Mechanic.....	\$ 34.58	14.25
Oiler.....	\$ 33.19	14.25
Scraper: Single bowl under 40 cubic yards.....	\$ 34.21	14.25
Scraper: Single bowl, including pups 40 cubic yards and over and tandem bowls.....	\$ 34.41	14.25
Trackhoe.....	\$ 34.21	14.25

IRON0024-003 11/01/2023

	Rates	Fringes
IRONWORKER, STRUCTURAL.....	\$ 37.23	22.84
Structural		

LAB00086-001 05/01/2009

	Rates	Fringes
Laborers:		
Pipelayer.....	\$ 18.68	6.78

PLUM0003-005 06/01/2023

ADAMS, ARAPAHOE, BOULDER, BROOMFIELD, DENVER, DOUGLAS,
JEFFERSON, LARIMER AND WELD COUNTIES

	Rates	Fringes
PLUMBER.....	\$ 48.23	19.77

PLUM0058-002 07/01/2023

EL PASO COUNTY

	Rates	Fringes
Plumbers and Pipefitters.....	\$ 43.90	16.83

PLUM0058-008 07/01/2023

PUEBLO COUNTY

	Rates	Fringes
--	-------	---------

Plumbers and Pipefitters.....\$ 43.90 16.83

PLUM0145-002 07/01/2023

MESA COUNTY

Rates Fringes

Plumbers and Pipefitters.....\$ 37.57 14.93

PLUM0208-004 06/02/2023

ADAMS, ARAPAHOE, BOULDER, BROOMFIELD, DENVER, DOUGLAS,
JEFFERSON, LARIMER AND WELD COUNTIES

Rates Fringes

PIPEFITTER.....\$ 44.56 19.72

SHEE0009-002 07/01/2023

Rates Fringes

Sheet metal worker.....\$ 38.47 20.83

TEAM0455-002 07/01/2023

Rates Fringes

Truck drivers:

Pickup.....\$ 25.46 4.77

Tandem/Semi and Water.....\$ 26.09 4.77

* SUC02001-006 12/20/2001

Rates Fringes

BOILERMAKER.....\$ 17.60

Carpenters:

Form Building and Setting...\$ 16.97 ** 2.74

All Other Work.....\$ 15.14 ** 3.37

Cement Mason/Concrete Finisher...\$ 17.31 2.85

IRONWORKER, REINFORCING.....\$ 18.83 3.90

Laborers:

Common.....	\$ 11.22 **	2.92
Flagger.....	\$ 8.91 **	3.80
Landscape.....	\$ 12.56 **	3.21

Painters:

Brush, Roller & Spray.....	\$ 15.81 **	3.26
----------------------------	-------------	------

Power equipment operators:

Backhoe.....	\$ 16.36 **	2.48
Front End Loader.....	\$ 17.24	3.23
Skid Loader.....	\$ 15.37 **	4.41

WELDERS - Receive rate prescribed for craft performing operation to which welding is incidental.

=====

** Workers in this classification may be entitled to a higher minimum wage under Executive Order 14026 (\$17.20) or 13658 (\$12.90). Please see the Note at the top of the wage determination for more information. Please also note that the minimum wage requirements of Executive Order 14026 are not currently being enforced as to any contract or subcontract to which the states of Texas, Louisiana, or Mississippi, including their agencies, are a party.

Note: Executive Order (EO) 13706, Establishing Paid Sick Leave for Federal Contractors applies to all contracts subject to the Davis-Bacon Act for which the contract is awarded (and any solicitation was issued) on or after January 1, 2017. If this contract is covered by the EO, the contractor must provide employees with 1 hour of paid sick leave for every 30 hours they work, up to 56 hours of paid sick leave each year. Employees must be permitted to use paid sick leave for their own illness, injury or other health-related needs, including preventive care; to assist a family member (or person who is like family to the employee) who is ill, injured, or has other health-related needs, including preventive care; or for reasons resulting from, or to assist a family member (or person who is like family to the employee) who is a victim of, domestic violence, sexual assault, or stalking. Additional information on contractor requirements and worker protections under the EO is available at <https://www.dol.gov/agencies/whd/government-contracts>.

Unlisted classifications needed for work not included within the scope of the classifications listed may be added after award only as provided in the labor standards contract clauses (29CFR 5.5 (a) (1) (iii)).

The body of each wage determination lists the classification and wage rates that have been found to be prevailing for the cited type(s) of construction in the area covered by the wage determination. The classifications are listed in alphabetical order of ""identifiers"" that indicate whether the particular rate is a union rate (current union negotiated rate for local), a survey rate (weighted average rate) or a union average rate (weighted union average rate).

Union Rate Identifiers

A four letter classification abbreviation identifier enclosed in dotted lines beginning with characters other than ""SU"" or ""UAVG"" denotes that the union classification and rate were prevailing for that classification in the survey. Example: PLUM0198-005 07/01/2014. PLUM is an abbreviation identifier of the union which prevailed in the survey for this classification, which in this example would be Plumbers. 0198 indicates the local union number or district council number where applicable, i.e., Plumbers Local 0198. The next number, 005 in the example, is an internal number used in processing the wage determination. 07/01/2014 is the effective date of the most current negotiated rate, which in this example is July 1, 2014.

Union prevailing wage rates are updated to reflect all rate changes in the collective bargaining agreement (CBA) governing this classification and rate.

Survey Rate Identifiers

Classifications listed under the ""SU"" identifier indicate that no one rate prevailed for this classification in the survey and the published rate is derived by computing a weighted average rate based on all the rates reported in the survey for that classification. As this weighted average rate includes all rates reported in the survey, it may include both union and non-union rates. Example: SULA2012-007 5/13/2014. SU indicates the rates are survey rates based on a weighted average calculation of rates and are not majority rates. LA indicates the State of Louisiana. 2012 is the year of survey on which these classifications and rates are based. The next number, 007 in the example, is an internal number used in producing the wage determination. 5/13/2014 indicates the survey completion date for the classifications and rates under that identifier.

Survey wage rates are not updated and remain in effect until a new survey is conducted.

Union Average Rate Identifiers

Classification(s) listed under the UAVG identifier indicate that no single majority rate prevailed for those classifications; however, 100% of the data reported for the classifications was union data. EXAMPLE: UAVG-OH-0010 08/29/2014. UAVG indicates that the rate is a weighted union average rate. OH indicates the state. The next number, 0010 in the example, is an internal number used in producing the wage determination. 08/29/2014 indicates the survey completion date for the classifications and rates under that identifier.

A UAVG rate will be updated once a year, usually in January of each year, to reflect a weighted average of the current negotiated/CBA rate of the union locals from which the rate is based.

WAGE DETERMINATION APPEALS PROCESS

1.) Has there been an initial decision in the matter? This can be:

- * an existing published wage determination
- * a survey underlying a wage determination
- * a Wage and Hour Division letter setting forth a position on a wage determination matter
- * a conformance (additional classification and rate) ruling

On survey related matters, initial contact, including requests for summaries of surveys, should be with the Wage and Hour National Office because National Office has responsibility for the Davis-Bacon survey program. If the response from this initial contact is not satisfactory, then the process described in 2.) and 3.) should be followed.

With regard to any other matter not yet ripe for the formal process described here, initial contact should be with the Branch of Construction Wage Determinations. Write to:

Branch of Construction Wage Determinations
Wage and Hour Division
U.S. Department of Labor

200 Constitution Avenue, N.W.
Washington, DC 20210

2.) If the answer to the question in 1.) is yes, then an interested party (those affected by the action) can request review and reconsideration from the Wage and Hour Administrator (See 29 CFR Part 1.8 and 29 CFR Part 7). Write to:

Wage and Hour Administrator
U.S. Department of Labor
200 Constitution Avenue, N.W.
Washington, DC 20210

The request should be accompanied by a full statement of the interested party's position and by any information (wage payment data, project description, area practice material, etc.) that the requestor considers relevant to the issue.

3.) If the decision of the Administrator is not favorable, an interested party may appeal directly to the Administrative Review Board (formerly the Wage Appeals Board). Write to:

Administrative Review Board
U.S. Department of Labor
200 Constitution Avenue, N.W.
Washington, DC 20210

4.) All decisions by the Administrative Review Board are final.

=====

END OF GENERAL DECISION"

Lead Protection Program Plan

Phase boundaries and timing are subject to changes and delays.

 **Phase 2** - Potholing: Winter 2023/Spring 2024
- Replacements: Spring/Summer 2024

 **Phase 3** - Potholing: Fall 2024
- Replacements: Winter 2024/Spring 2025

 **Phase 4** - Potholing: Spring/Summer 2025
- Replacements: Summer/Fall 2025

Phase 5 includes select properties outside these phased boundaries. Potholing is scheduled for Winter 2025/Spring 2026 and replacements in Summer/Fall 2026



The City makes no representation or warranty as to its accuracy or completeness, and in particular, its accuracy in labeling or displaying dimensions, contours, property boundaries, or placement or location of any map features thereon. THE CITY OF GREELEY MAKES NO WARRANTY OF MERCHANTABILITY OR WARRANTY FOR FITNESS OF USE FOR A PARTICULAR PURPOSE, EXPRESSED OR IMPLIED, WITH RESPECT TO THESE MAP PRODUCTS OR THE UNDERLYING DATA. Any users of these map products, map applications, or data, accepts same AS IS, WITH ALL FAULTS, and assumes all responsibility for the use thereof, and further covenants and agrees to hold the City harmless from and against all damage, loss, or liability arising from any use of this map product, in consideration of the City's having made this information available. Independent verification of all data contained herein should be obtained by any user of these map products, or the underlying data. The City disclaims, and shall not be held liable for, any and all damage, loss, or liability, whether direct, indirect, or consequential, which arises or may arise from these map products or the use thereof by any person or entity.

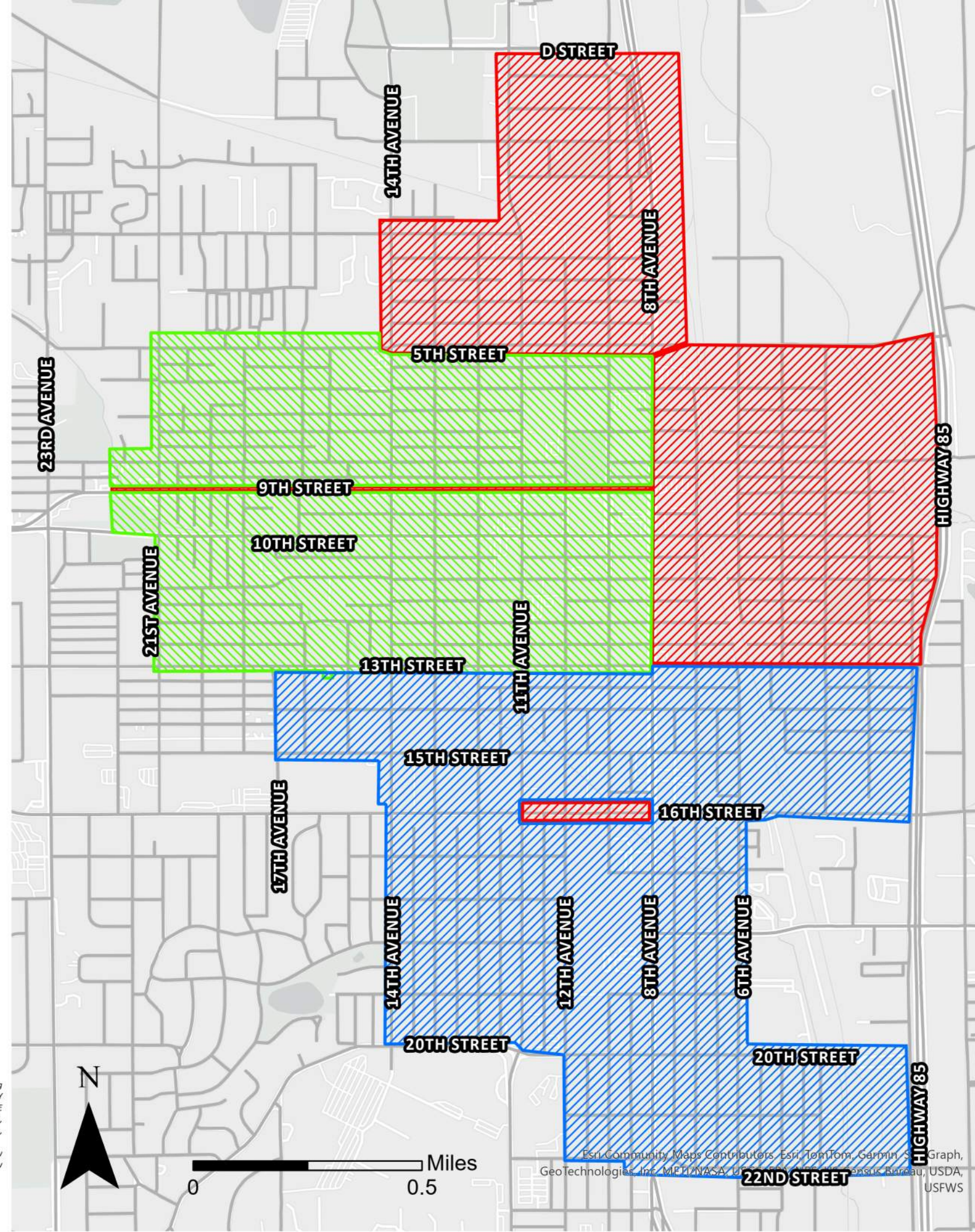

Esri Community Maps Contributors, Esri, TomTom, Garmin, Graph, GeoTechnologies, Inc, METANASA, USGS, National Geographic, USGS, USFS, USFWS

Attachment B-1 - Potable Water Service Line Standard Drawing

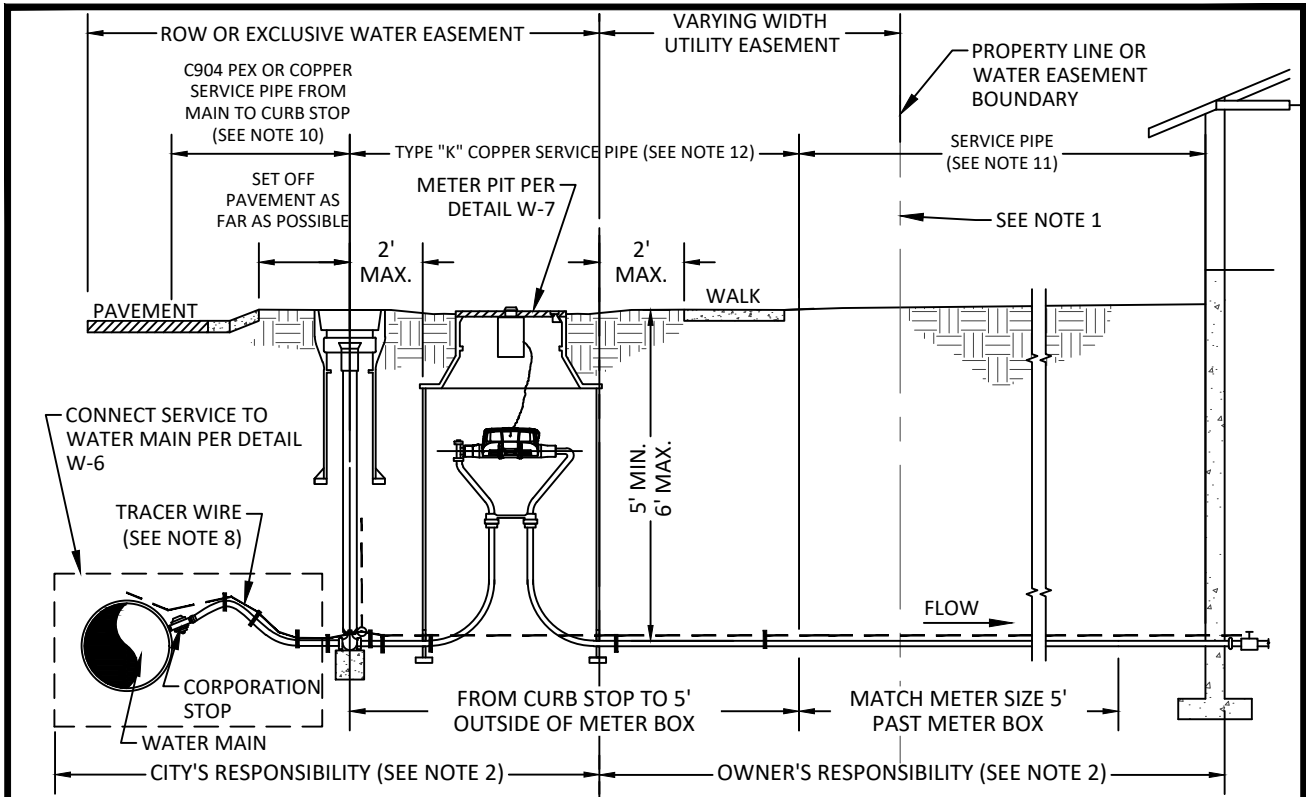

ELEVATION VIEW

NOTES:

1. PLACEMENT OF CURB STOP SERVICE BOX MAY VARY FROM LANDSCAPE PARKWAY TO A MAXIMUM OF ±1 FOOT OF THE PROPERTY LINE. ANY VARIANCE OF LOCATION OF CURB STOP MUST BE APPROVED PRIOR TO CONSTRUCTION.
2. WATER DEPARTMENT'S RESPONSIBILITY SHALL BE THE WATER MAIN, THE METER INSIDE THE METER PIT, THE CORPORATION STOP, AND SERVICE PIPING FROM THE WATER MAIN UP TO DOWNSTREAM OF METER. PROPERTY OWNER'S RESPONSIBILITY SHALL INCLUDE EVERYTHING DOWNSTREAM OF METER STRUCTURE.
3. SHOULD ANY SITUATION ARISE OTHER THAN SHOWN CONCERNING THE DEPTH OR OBSTRUCTION OF SERVICE LINE OR THE PLACEMENT OF THE METER PIT OR STOP BOX, CALL (970) 350-9317 AND ASK FOR METER SERVICES DIVISION.
4. REFER TO WATER & SEWER (W&S) STANDARD DRAWINGS AND CONSTRUCTION SPECIFICATIONS (SPECIFICATIONS) FOR METER INSTALLATION REQUIREMENTS.
5. POTABLE WATER SERVICE METER PITS/ VAULTS SHALL BE LOCATED IN A LANDSCAPE PARKWAY AREA WITHIN 2 FEET OF THE CURB STOP. SEE DESIGN CRITERIA, LATEST REVISION, FOR METER PIT LOCATION.
6. CURB STOP IS TO BE MINNEAPOLIS PATTERN OR APPROVED EQUAL.
7. CURB STOP MUST BE INSTALLED WITH EITHER PLASTIC OR STAINLESS STEEL PIPE INSERTS TO ENSURE PROPER COMPRESSION FITTING ON C904 CROSS-LINKED PEX PIPE.
8. INSTALL TRACER WIRE ACCORDING TO CITY OF GREELEY W&S SPECIFICATIONS AND STANDARD DETAILS, LATEST REVISION.
9. ALL BURIED PIPE, FITTINGS, VALVES, AND APPURTENANCES SHALL BE INSTALLED AND RESTRAINED IN ACCORDANCE WITH W&S SPECIFICATIONS, LATEST REVISION.
10. COPPER OR C904 CROSS-LINKED PEX SERVICE LINE SHALL BE INSTALLED FROM THE CORPORATION STOP TO CURB STOP. REFER TO W&S CONSTRUCTION SPECIFICATIONS FOR APPROVED SERVICE PIPE PRODUCT AND MFR REQUIREMENTS.
11. FROM 5 FT PAST THE METER PIT ON THE OWNER SIDE UP TO BUILDING STRUCTURE SHALL BE IN ACCORDANCE WITH BUILDING CODE AND DRINKING WATER REQUIREMENTS.
13. TYPE "K" COPPER SHALL BE PLACED FROM THE CURB STOP, THROUGH THE METER PIT, AND UP TO 5 FEET PAST THE METER PIT ON CUSTOMER SIDE.
14. ALL SERVICE PIPE SHALL BE SIZED ACCORDING TO SERVICE TAP INSIDE DIAMETER AND MUST COMPLY WITH AWWA C904. SEE W&S DESIGN CRITERIA, LATEST REVISION.
15. UPPER HALF OF STANDARD VALVE BOX SHALL BE PLACED OVER CURB STOP AND TRACER WIRE TEST STATION LOOP ACCORDING TO W&S SPECIFICATIONS, LATEST REVISION.



POTABLE WATER SERVICE LINE, STOP BOX & METER INSTALLATION (OUTSIDE LANDSCAPE PARKWAY) DETAIL W-9A

DATE: JANUARY 2023

SCALE: N.T.S.

Attachment B-2 - Potable Water Service Line Standard Drawing

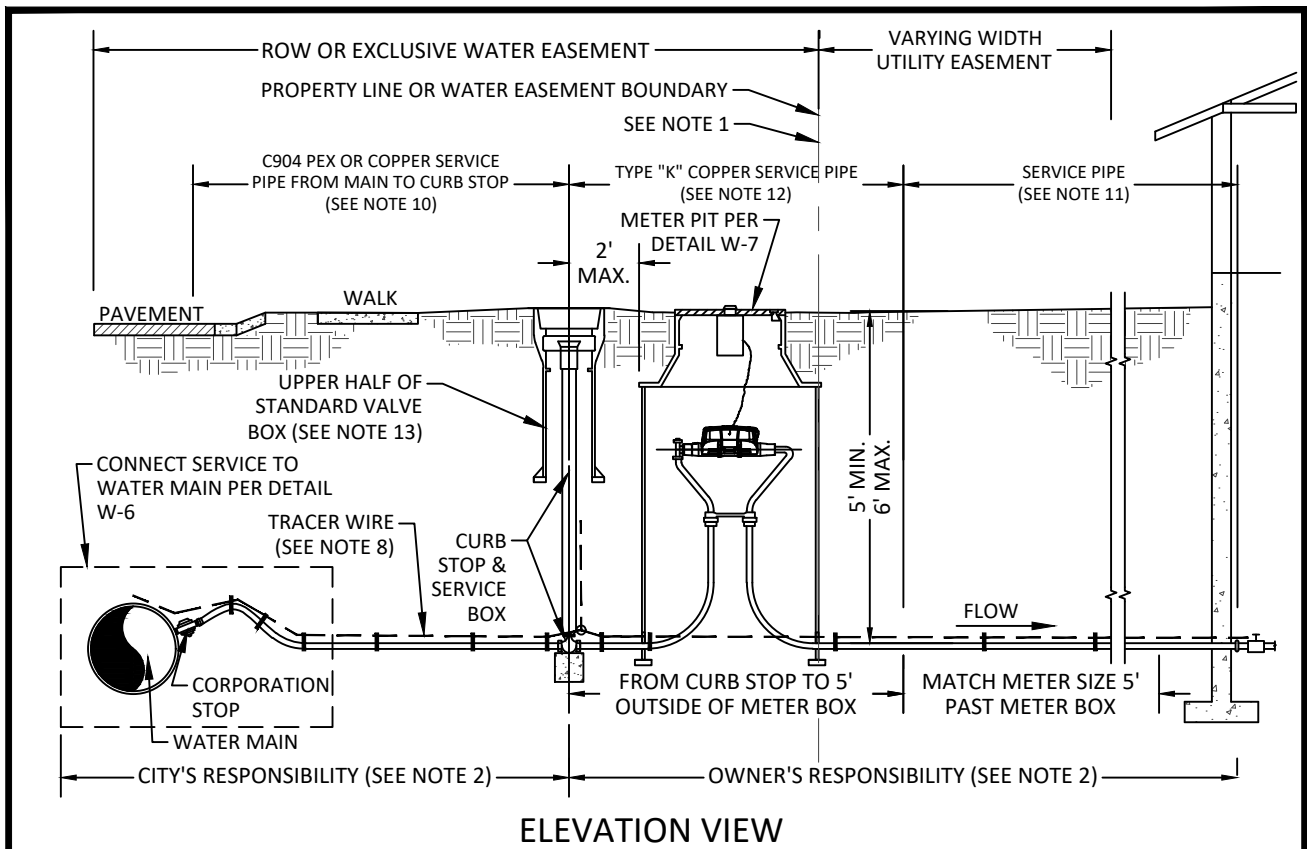

NOTES:

1. PLACEMENT OF CURB STOP SERVICE BOX MAY VARY FROM LANDSCAPE PARKWAY TO A MAXIMUM OF ±1 FOOT OF THE PROPERTY LINE. ANY VARIANCE OF LOCATION OF CURB STOP MUST BE APPROVED PRIOR TO CONSTRUCTION.
2. WATER DEPARTMENT'S RESPONSIBILITY SHALL BE THE WATER MAIN, THE METER INSIDE THE METER PIT, THE CORPORATION STOP, AND SERVICE PIPING FROM THE WATER MAIN UP TO DOWNSTREAM OF METER. PROPERTY OWNER'S RESPONSIBILITY SHALL INCLUDE EVERYTHING DOWNSTREAM OF METER STRUCTURE.
3. SHOULD ANY SITUATION ARISE OTHER THAN SHOWN CONCERNING THE DEPTH OR OBSTRUCTION OF SERVICE LINE OR THE PLACEMENT OF THE METER PIT OR STOP BOX, CALL (970) 350-9317 AND ASK FOR METER SERVICES DIVISION.
4. REFER TO WATER & SEWER (W&S) STANDARD DRAWINGS AND CONSTRUCTION SPECIFICATIONS (SPECIFICATIONS) FOR METER INSTALLATION REQUIREMENTS.
5. POTABLE WATER SERVICE METER PITS/ VAULTS SHALL BE LOCATED IN A LANDSCAPE PARKWAY AREA WITHIN 2 FEET OF THE CURB STOP. SEE DESIGN CRITERIA, LATEST REVISION, FOR METER PIT LOCATION.
6. CURB STOP IS TO BE MINNEAPOLIS PATTERN OR APPROVED EQUAL.
7. CURB STOP MUST BE INSTALLED WITH EITHER PLASTIC OR STAINLESS STEEL PIPE INSERTS TO ENSURE PROPER COMPRESSION FITTING ON C904 CROSS-LINKED PEX PIPE.
8. INSTALL TRACER WIRE ACCORDING TO CITY OF GREELEY W&S SPECIFICATIONS AND STANDARD DETAILS, LATEST REVISION.
9. ALL BURIED PIPE, FITTINGS, VALVES, AND APPURTENANCES SHALL BE INSTALLED AND RESTRAINED IN ACCORDANCE WITH W&S SPECIFICATIONS, LATEST REVISION.
10. COPPER OR C904 CROSS-LINKED PEX SERVICE LINE SHALL BE INSTALLED FROM THE CORPORATION STOP TO CURB STOP. REFER TO W&S CONSTRUCTION SPECIFICATIONS FOR APPROVED SERVICE PIPE PRODUCT AND MFR REQUIREMENTS.
11. FROM 5 FT PAST THE METER PIT ON THE OWNER SIDE UP TO BUILDING STRUCTURE SHALL BE IN ACCORDANCE WITH BUILDING CODE AND DRINKING WATER REQUIREMENTS.
12. TYPE "K" COPPER SHALL BE PLACED FROM THE CURB STOP, THROUGH THE METER PIT, AND UP TO 5 FEET PAST THE METER PIT ON CUSTOMER SIDE.
13. ALL SERVICE PIPE SHALL BE SIZED ACCORDING TO SERVICE TAP INSIDE DIAMETER AND MUST COMPLY WITH AWWA C904. SEE W&S DESIGN CRITERIA, LATEST REVISION.
14. UPPER HALF OF STANDARD VALVE BOX SHALL BE PLACED OVER CURB STOP AND TRACER WIRE TEST STATION LOOP ACCORDING TO W&S SPECIFICATIONS, LATEST REVISION.



**POTABLE WATER SERVICE LINE, STOP BOX & METER INSTALLATION
(INSIDE LANDSCAPE PARKWAY)
DETAIL W-9B**

DATE: JANUARY 2023

SCALE: N.T.S.

Attachment C - Potable Water Service Line Connection

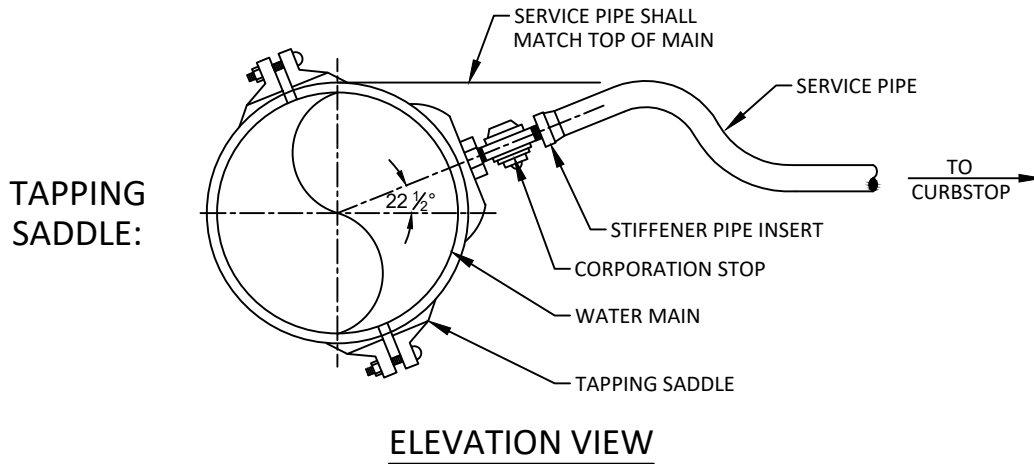

TYPE OF PIPE AND SIZE OF TAP												
PIPE SIZE	CAST IRON					DUCTILE IRON					PVC C-900	
	3/4"	1"	1 1/2"	2"	3"&4"	3/4"	1"	1 1/2"	2"	3"&4"	< 2"	> 2"
4"	S	S	NO	NO	TSV	S	S	NO	NO	TSV	S	TSV
6"	S	S	S	S	TSV	S	S	S	S	TSV	S	TSV
8"	S	S	S	S	TSV	S	S	S	S	TSV	S	TSV
12"	S	S	S	S	TSV	S	S	S	S	TSV	S	TSV
16"	S	S	S	S	TSV	S	S	S	S	TSV	N/A	N/A

- "S" - TAPPING SADDLE REQUIRED, ALL SADDLES SHALL HAVE AWWA TAPER THREADS.
- "NO" - NO TAP PERMITTED WITH OR WITHOUT A SADDLE, A TEE CONNECTION MAY BE PERMITTED IF SPECIFICALLY AUTHORIZED BY THE WATER DEPARTMENT.
- "TSV" - TAPPING SLEEVE AND VALVE REQUIRED.
- "N/A" - NOT APPLICABLE.

NOTES:

1. REFERENCE CITY OF GREELEY, WATER & SEWER CONSTRUCTION SPECIFICATIONS, LATEST REVISION, FOR TAPPING SADDLE SPECIFICATIONS.
2. EXISTING STEEL MAINS, TWELVE INCHES (12") IN DIAMETER OR LESS, SHALL BE TAPPED USING A CITY ACCEPTED TAPPING SADDLE.
3. ALL BURIED PIPE, FITTINGS, VALVES, AND APPURTENANCES SHALL BE RESTRAINED AND INSTALLED PER CITY OF GREELEY WATER & SEWER SPECIFICATIONS, LATEST REVISION.
4. INSTALL TRACER WIRE ACCORDING TO CITY OF GREELEY WATER & SEWER SPECIFICATIONS AND W&S UTILITY LOCATING ("UL") STANDARD DETAILS, LATEST REVISION OF EACH.
5. REFER TO CITY OF GREELEY WATER AND SEWER SPECIFICATIONS, LATEST REVISION, FOR PRODUCT AND MFR SPECIFICATIONS.
6. THIS DETAIL ALSO APPLIES TO NON-POTABLE IRRIGATION SERVICE CONNECTIONS TO NON-POTABLE IRRIGATION MAINS.
7. SERVICE TAPS ON WATER MAINS LARGER THAN 16" MAY BE CONSIDERED UNDER CERTAIN CIRCUMSTANCES WITH SPECIAL DESIGN ON A CASE-BY-CASE SCENARIO.
8. FOR ANY NEW WATER SERVICES TAPPING INTO EXISTING MAINS THE CONTRACTOR SHALL NOTIFY THE CITY 72 HOURS PRIOR AT 970-350-9320.



WATER SERVICE CONNECTION

DETAIL W-6

DATE: JANUARY 2023

SCALE: N.T.S.

Phase 2 Service Line Replacement Map (DRAFT)

- Private Replacement
- Public Replacement
- Full Replacement

0 500 1,000 Feet

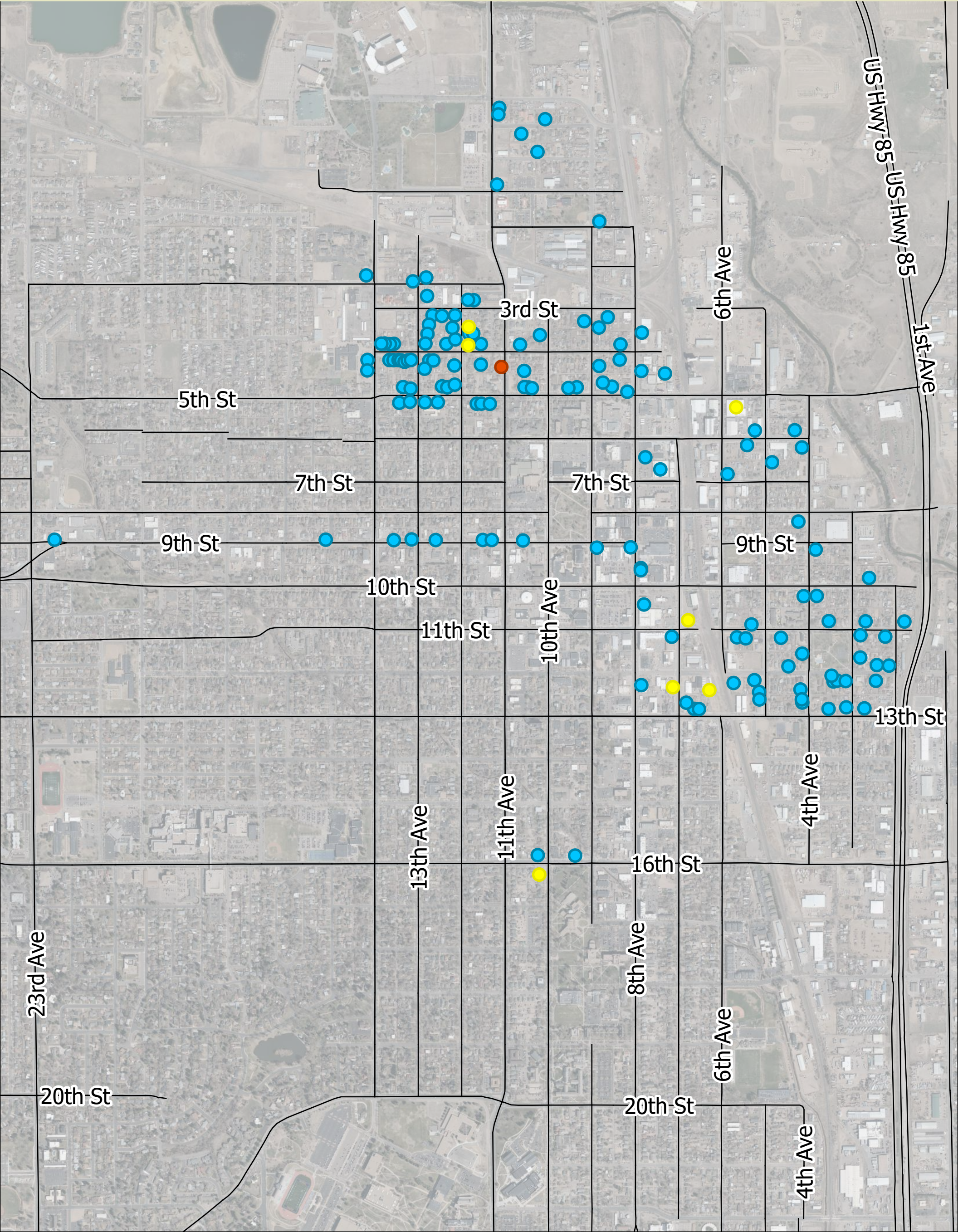

- A. Unless specifically indicated in the *Water Master Plan*, sixteen-inch (16") mains are required every mile and twelve-inch (12") mains are required every half-mile. Other distribution mains shall have a minimum diameter of eight inches (8").
- B. Hydrant leads connecting to the potable distribution system shall be six inches (6") in diameter. Other pipe diameters for hydrant leads are prohibited.

3.07 DEPTH OF BURY

- A. The minimum depth of cover shall be five (5) feet and the maximum depth of cover should generally not exceed six (6) feet. Design preference is to minimize lowering which can be challenging to locate and maintain.
- B. When design or constructability constraints are present, deeper or shallower water main installation may be permitted only with acceptance from the City. Additional design and installation considerations may be required by the City depending on the situation. Design considerations should minimize additional fittings and elevation changes where feasible.

3.08 CONNECTIONS TO THE EXISTING POTABLE WATER SYSTEM

- A. Main connections to the existing potable water distribution system shall be made by wet tap or cut in tee. All wet taps and all cut-in tees on mains smaller than 16" diameter shall be made by the Contractor under the direct supervision of the City. It is the Contractor's responsibility to provide all approved tapping materials (tapping sleeves, tapping valves, insulator kit, etc.). Taps for new 8" and 12" main connections to existing 16" or larger mains shall be performed by the City unless otherwise directed.
- B. Connections to the existing transmission mains or distribution mains larger than sixteen-inch (16") shall be limited and must be approved by City.
- C. For wet taps on existing transmission mains or sixteen-inch (16") and larger distribution mains, manufacturer's shop drawings and specifications for the proposed tapping sleeve shall be submitted to the City for review and acceptance prior to installation of the tapping sleeve by the Contractor.
- D. Taps on existing transmission mains or sixteen-inch (16") and larger distribution mains shall require the installation of an insulator kit between the tapping sleeve and tapping valve.
- E. Connection to cast iron mains constructed prior to 1950 may require replacement or non-standard fittings which must be reviewed and approved by City of Greeley Water & Sewer department.
- F. Construction documents shall include a note for all wet taps: "Contractor to reference specifications for approved tapping materials and prior to installation shall contact Distribution for direct supervision of installation by the City."

3.09 LOCATION AND LOOPING OF POTABLE WATER MAINS

- A. Potable water mains shall be located in the center of a dedicated street right-of-way, where feasible, or within a dedicated exclusive easement of appropriate width. If narrow street

**DESIGN CRITERIA
AND
CONSTRUCTION SPECIFICATIONS**

**STREETS
VOLUME I**



JULY 2015

DEPARTMENT OF PUBLIC WORKS

CITY OF GREELEY, COLORADO

**TABLE 2.08.1
Flexible Pavement Design Criteria**

ROAD CLASSIFICATION	20-Year Design Traffic Information		Serviceability Index (psi)			Reliability	Aggregate Base Thickness Class 5 or 6		Asphalt Thickness, inches		Grading S (3/4 inch aggregate)		Grading SG (1-1/2 inch aggregate)		Minimum Structural Number (3)
	Min. EDLA (2)	Min. ESAL	Si Init	St Final	D psi	%	Layer, inches		Layer, inches		Layer, inches		Layer, inches		
							Min	Max	Min	Max	Min	Max	Min	Max	
LOCAL															
Residential two lane(4)	5	36500	4.5	2.0	2.5	65	6	6.5	3.5	5.5	2	3	3.0	4.0	2.39
Residential one lane(1)	10	73000	4.5	2.0	2.5	70	6	9.0	3.5	6.0	2	3	3.0	4.5	2.49
Industrial/commercial	50	365000	4.5	2.3	2.2	75	6	10.0	5.0	7.5	2	3	3.0	6.0	3.29
COLLECTOR															
Minor	25	182500	4.5	2.3	2.2	75	6	7.0	5.0	7.0	2	3	3.0	5.5	2.97
Major	50	365000	4.5	2.3	2.2	85	6	8.0	6.0	8.0	2	3	3.0	6.5	3.48
Industrial/commercial	100	730000	4.5	2.3	2.2	85	6	11.0	6.0	9.0	2	3	3.0	7.5	3.85
ARTERIAL															
Two lane	100	730000	4.5	2.5	2.0	90	6	11.5	6.0	9.5	2	3	3.0	8.0	4.08
Four lane	200	1460000	4.5	2.5	2.0	90	6	15.0	6.5	10.5	2	3	3.0	9.0	4.51
Six lane	300	2190000	4.5	2.5	2.0	90	6	17.0	6.5	11.0	2	3	3.0	9.5	4.77

NOTES:

1. Wearing surface course shall be Grading S or SX for residential roadway classification and Grading S for collectors, arterials, and all industrial/commercial roadways.
2. EDLA shall be calculated based on projected traffic uses. Minimum EDLA values are as given for the design lane. The Engineer may require greater EDLA values if warranted.
3. Minimum structural numbers are based on subgrade R-value=5 and MR (Resilient Modulus) =555 x R + 1000.
4. Single lane refers to a paved surface less than 20 feet wide, including residential alleys.
5. Min/max lift thicknesses: Grade SX - 1-1/2"/2-1/2", Grades S - 2"/3", Grade SG - 3"/5"

D. COMPACTION IN NEW UTILITY TRENCHES, CULVERTS, ETC.

All utility trenches within the street right-of-way (including service lines) must be mechanically compacted to not less than 95% of maximum density within \pm two percent (2%) of optimum moisture content as determined by AASHTO T99. Alternatively, utility trenches can also be backfilled with flowable fill to within one foot of finished grade. This includes gas, electric, TV cable, telephone and other utilities lines serving the development. All water and sewer services, including water and sewer main stub-outs, shall be installed prior to street construction. Trench backfill in utility easements within 20 feet of right-of-way shall be mechanically compacted to 95% maximum density or backfilled with flowable fill to within one foot of finish grade. Trench backfill in utility easements beyond 20 feet from right-of-way shall be compacted to 90% maximum density. Water settlement and/or jetting of trenches shall not be permitted.

E. MATERIALS AND QUALITY CONTROL TESTING

1. The Contractor/Owner is responsible for the quality control testing and protection of work until a certificate of substantial completion is issued by the City of Greeley. All quality control test results shall be made available to the Engineer immediately after testing. The City will provide acceptance testing. Acceptance testing may include but not be limited to tests associated with placing of concrete, asphalt, and base course subgrade preparation, and trench compaction. The Contractor/Owner shall coordinate with the Project Representative as to when he or she is ready for acceptance tests. See Appendix (Schedules For Quality Control and Acceptance Sampling and Testing).
2. The Contractor/Owner shall be responsible for the costs associated with re-testing due to failed acceptance tests.

SECTION 02223

STRUCTURAL BACKFILL

PART 1 – GENERAL

1.1 SCOPE

This section includes the material and construction specifications for structural backfill and filter materials.

PART 2 – MATERIALS

2.1 STRUCTURAL BACKFILL

- A. Structural Backfill shall comply with CDOT Standard Specifications for Class 1 material and meet the following requirements from laboratory sieves:

CLASS 1

SIEVE DESIGNATION	% BY WEIGHT PASSING LAB SIEVES
2 inch	100
No. 4	30 - 100
No. 50	10 - 60
No. 200	5 - 20

Class 1 Structural Backfill shall be used on all bridges, box culverts, or where otherwise specified. In addition this material shall have a liquid limit not exceeding 35 and a plasticity index of not over 6 when determined in conformity with AASHTO T 89 and T 90.

- B. Class 2 Structural Backfill shall be composed of suitable materials developed on the project. To be suitable for use under this classification, backfill shall be free of frozen lumps, wood, or other organic material. If the material contains rock fragments or other materials that, in the opinion of the Engineer, will be injurious to the structure, the native material shall not be used for backfilling, and the Contractor shall be required to furnish "Class 1 Structural Backfill" material.
- C. Flowable backfill may be substituted for Structure Backfill (Class 1) and (Class 2) where it is used to backfill culvert pipes, storm sewer pipes and utility cuts. It shall not be used to backfill abutments.

2.2 FLOWABLE BACKFILL

Flowable backfill meeting the following requirements shall be used to backfill all open cuts in portions of public right-of-way beneath existing paving, curb, gutter, or sidewalk improvements. Alternate backfill methods for large excavations will be considered on an individual review basis with the City Engineer.

Flowable backfill shall consist of a controlled low-strength, self-leveling concrete material composed of various combinations of cement, fly ash, aggregate, water, and chemical mixture. It shall have a design compressive strength between 50 psi and 150 psi at 28 days when tested in accordance with ASTM D 4832. The mix shall result in a product having a slump in the range of 7 to 10 inches at the time of placement. The Contractor shall submit a mix design for approval by the City prior to placement. The mix design shall be supported by laboratory test data verifying compliance with the 28-day compressive strength requirements.

Compaction of flowable backfill will not be required.

Flowable backfill shall not be allowed to freeze.

SCHEDULE FOR QUALITY CONTROL SAMPLING AND TESTING

IDENTIFICATION	TYPE OF TEST REQUIRED	MINIMUM SAMPLING/TESTING FREQUENCY
Sewer/Water /Non-Potable Water Compaction	Moisture/Density Curve	One Per Soils Type
	% Compaction % Moisture	Mainline: One Test Every 200 L.F. Every Other 8" lift of Backfill. Water Service: One Test Every Other 8" lift of Backfill. Sewer Service: One Test Every Other 8" lift of Backfill. Water Valve/Manhole: One Test Each 8" lift of Backfill. Test Opposite Sides

Page 227

GUIDELINE FOR QUALITY ASSURANCE SAMPLING AND TESTING

IDENTIFICATION	TYPE OF TEST REQUIRED	MINIMUM SAMPLING/TESTING FREQUENCY
Sewer/Water Compaction	Moisture/Density Curve	One Per Soils Type
	% Compaction % Moisture	Mainline: One Test Every 1000 L.F. Water Service: One Test Per 20 Services. Sewer Service: One Test Per 20 Services. Water Valve/Manhole: At Inspectors Discretion. Test Opposite Sides

Page 228