



BUILDING GUIDE

COLORADO CHAPTER OF THE INTERNATIONAL CODE COUNCIL

SINGLE FAMILY RESIDENTIAL PATIO COVERS AND CARPORTS

How to use this guide

Check with your jurisdiction regarding type of submittal (paper or electronic) and additional requirements. Draw to scale and complete the following (hint: use graph paper with $\frac{1}{4}$ " squares. Example: $\frac{1}{4}$ " = 1').

1. **Complete this building guide** by filling in the blanks on page three through five and indicate which construction details will be used.
2. **Provide 2 plot plans** (site plans) showing the dimensions of your project and its relationship to existing buildings and/or structures on the property. The distances to the existing property lines shall be drawn to scale. See page 2.
3. **Fill out building permit application.**

The majority of permit applications are process with little delay. The submitted documents will help determine if the project is in compliance with building safety codes, zoning ordinances and other applicable laws.

The Colorado Chapter of The International Code council is a professional organization seeking to promote the public health, safety, and welfare to building construction. We appreciate your feedback and suggestions. Please write to Colorado Chapter of the International Code Council, at P.O. Box 961, Arvada, CO 80001. This Building guide can be found on the Colorado Chapter of the International Code Council website at <http://www.coloradochaptericc.org>

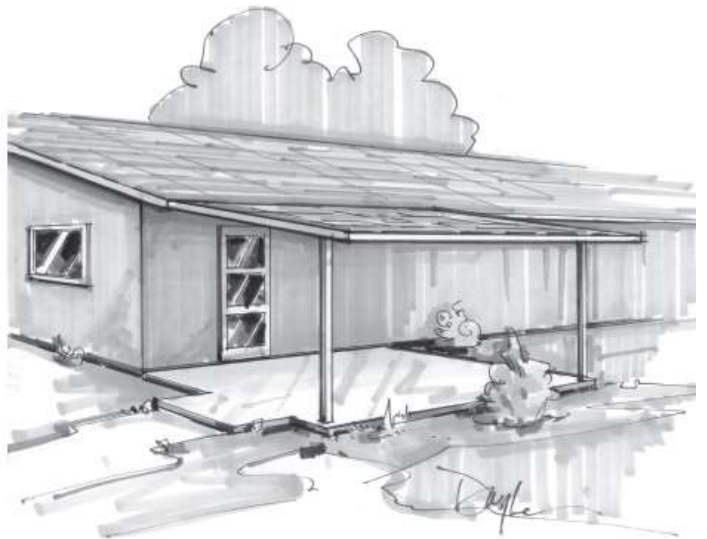

This handout was developed by the Colorado Chapter of The International Code council as a basic plan submittal under the International Residential Code, edition 2021. It is not intended to cover all circumstances. Check with your Building Safety department for additional requirements.

SINGLE FAMILY RESIDENTIAL PATIO COVERS AND CARPORTS

SITE PLAN

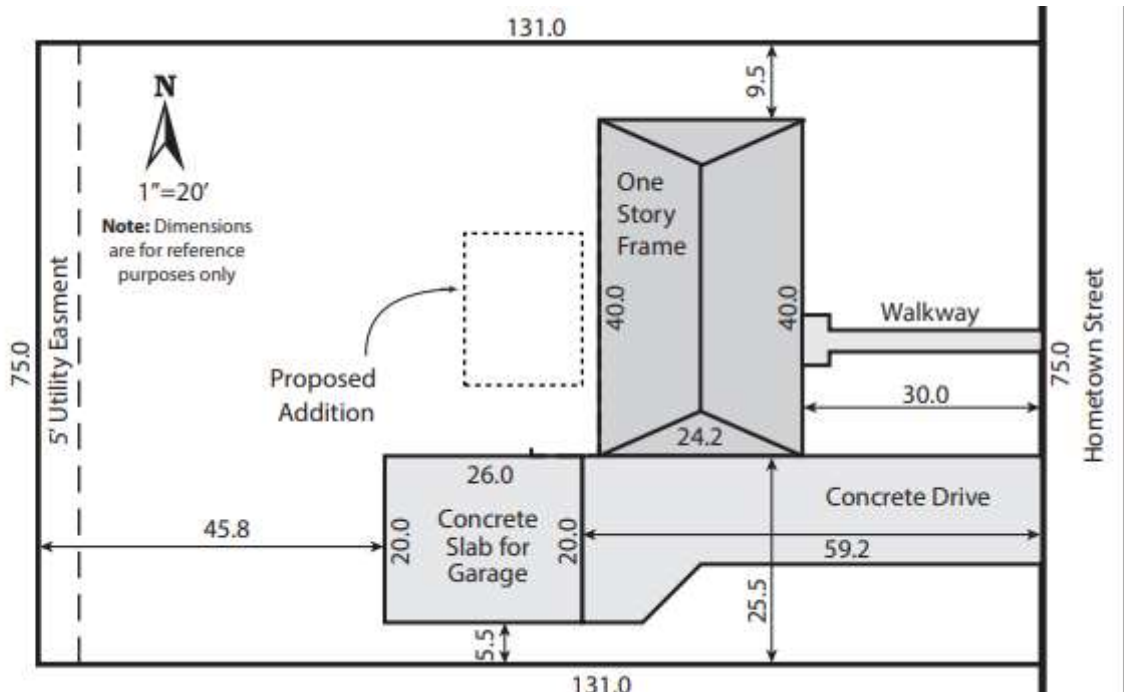

FOR ALL DETAILS ON PAGE 4 – NOTCHES ON CANTILEVERED PORTIONS OF RAFTERS ARE PERMITTED PROVIDED THE DIMENSIONS OF THE REMAINING PORTION OF THE RAFTER IS NOT LESS THAN 3 1/2 INCHES (89 MM) AND THE LENGTH OF THE CANTILEVER DOES NOT EXCEED 24 INCHES (610 MM).

This handout was developed by the Colorado Chapter of The International Code Council as a basic plan submittal under the International Residential Code, edition 2021. It is not intended to cover all circumstances. Check with your Building Safety department for additional requirements.

SINGLE FAMILY RESIDENTIAL PATIO COVERS AND CARPORTS

ADDRESS: _____

1. Fill in the blanks with dimensions and materials which will be used to build the structure. Please print legibly.
2. Indicate in the check boxes which details from page 4 and 5 will be used. Please note your project may be subject to fire restrictive construction requirements. Please refer to page 6 for further information on fire constructive requirements. Zoning approval is required for all projects.
3. Roofing to be installed per manufacture instructions, including low slope application, and required inspections made.

SIZE AND AMOUNT OF LAGS
(EXAMPLE: TWO ½" X 4 ½" LAGS @ 16 O.C.)

ROOF COVERINGS
(EXAMPLE: CLASS A 3 TAB SHINGLE)

ROOF PITCH _____
(EXAMPLE: 4:12)

UNDERLAYMENT
(EXAMPLE: #19 FELT WITH 19"

SHEATHING
(EXAMPLE: ½" EXTERIOR PLYWOOD)

WOOD SPECIES AND GRADE
(EXAMPLE: SOUTHERN PINE #2)

2X _____" RAFTERS SPACED _____" O.C.
(EXAMPLE: 2 X 8 RAFTERS SPACE 24"

() _____" X _____" BEAM
(EXAMPLE: (2) 2" X 10")

SPAN _____
(EXAMPLE: 12' 0")

SIDING
(FOR ALTERNATE B ONLY)

_____ " X _____ " POSTS
(Example: 4" x 4")
SPACED _____ APART
(Example: 6')

CAISSON SIZE _____
(EXAMPLE: 12" DIAMETER)
FOOTING _____ " X _____ "
ALTERNATE C ONLY

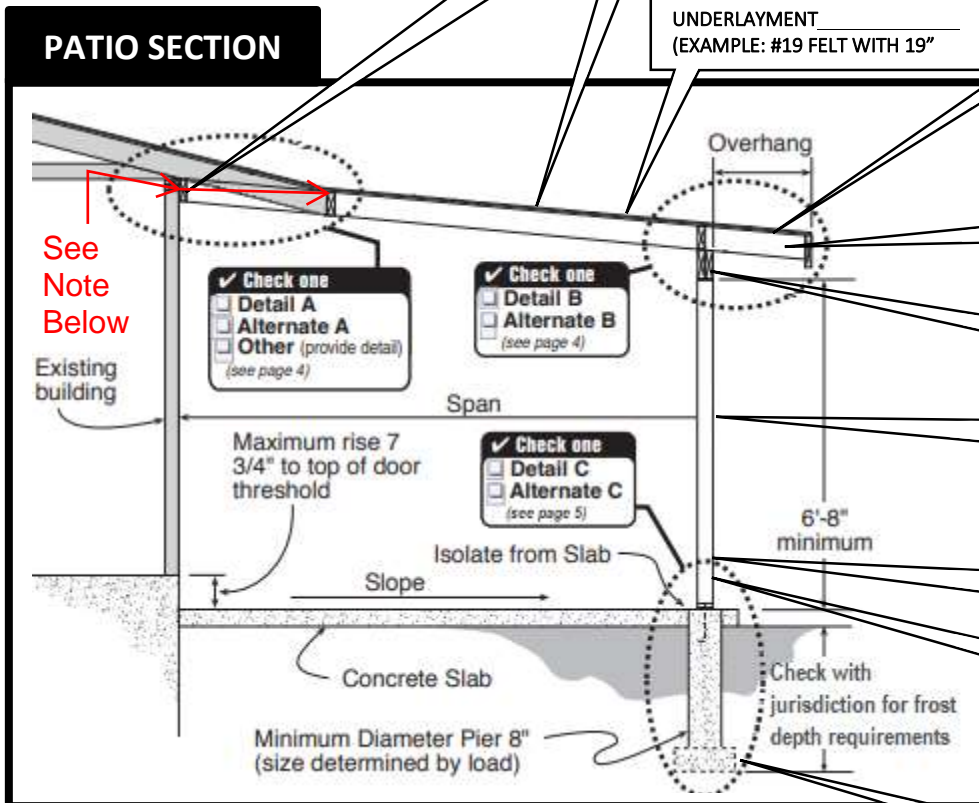

**Walls, post and overhangs closer than 5' to property line to be 1-hour rated. Projections between 5' and 2' from the property line to be rated for 1-hour from the underside. See authority having jurisdiction for options, and for homes with Fire Sprinklers.
 **No closer than 2 feet to property line.
 **Beam splices to occur over posts with 1 ½" bearing.

This handout was developed by the Colorado Chapter of The International Code council as a basic plan submittal under the International Residential Code, edition 2021. It is not intended to cover all circumstances. Check with your Building Safety department for additional requirements.

Structures cannot be permanently attached to Manufactured or Mobile Homes. Additional Post and Beam construction is required adjacent to dwelling.

SINGLE FAMILY RESIDENTIAL PATIO COVERS AND CARPORTS

■ DETAIL A

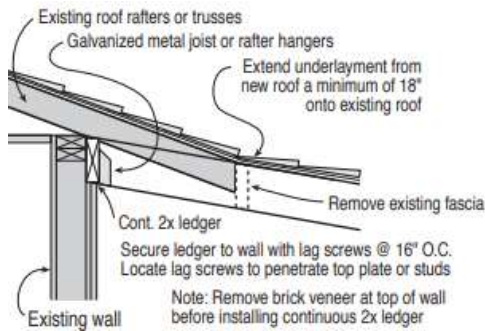

■ ALTERNATE DETAIL A

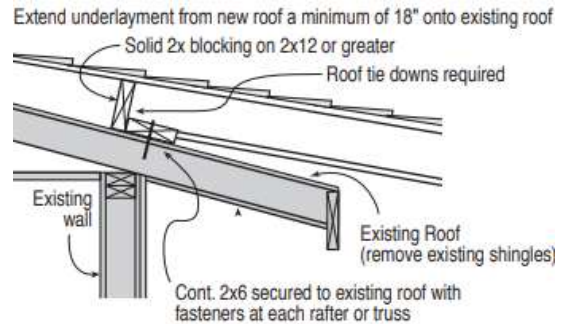

■ DETAIL B

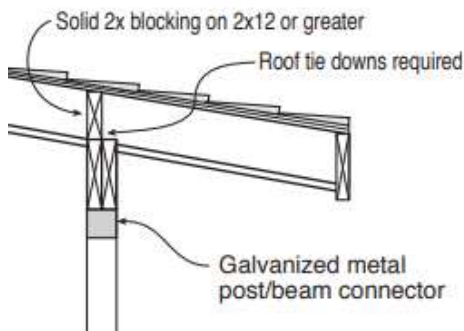

■ ALTERNATE DETAIL B 1-HOUR WALL

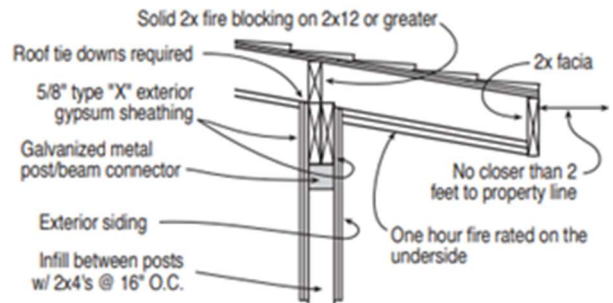

This handout was developed by the Colorado Chapter of The International Code Council as a basic plan submittal under the International Residential Code, edition 2021. It is not intended to cover all circumstances. Check with your Building Safety department for additional requirements.

SINGLE FAMILY RESIDENTIAL PATIO COVERS AND CARPORTS

■ DETAIL C

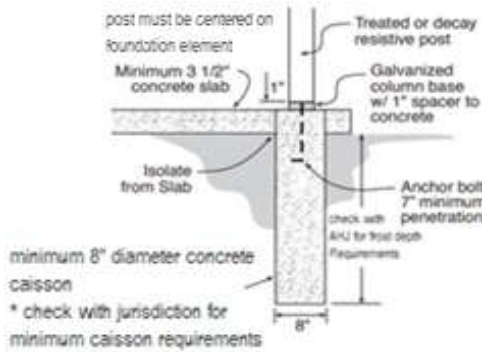

■ ALTERNATE DETAIL C 1-HOUR WALL

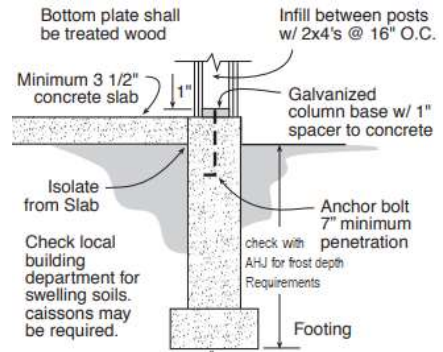

■ DETAIL D

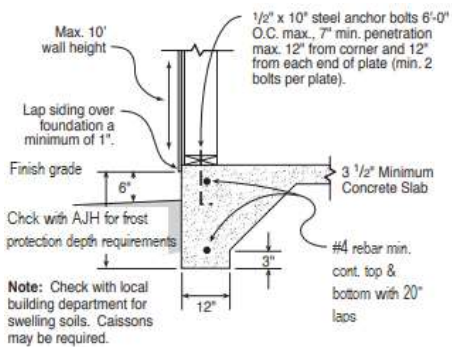

■ ALTERNATE DETAIL D 1-HOUR WALL

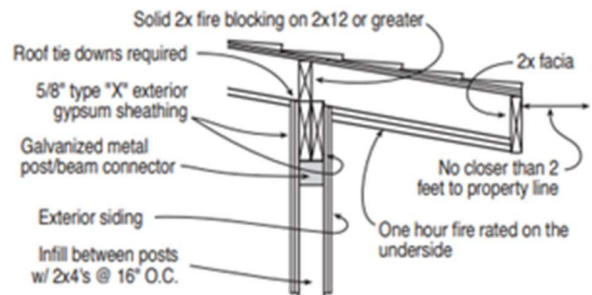

This handout was developed by the Colorado Chapter of The International Code council as a basic plan submittal under the International Residential Code, edition 2021. It is not intended to cover all circumstances. Check with your Building Safety department for additional requirements.

SINGLE FAMILY RESIDENTIAL PATIO COVERS AND CARPORTS

1. Projections cannot be closer than 2 feet to the lot line. Projections that have a fire separation distance of less than 5 feet from the lot line in unsprinklered buildings, or less than 3 feet in sprinklered buildings, are required to be protected on the underside with 1-hour fire-resistant construction. The underside protection may be omitted where fireblocking is provided or gable vents openings are not present.
2. Total area of the openings in a wall with a fire separation distance that is equal to or greater than 3 feet, but less than 5 feet from the lot line, be less than 25 percent of the maximum wall area

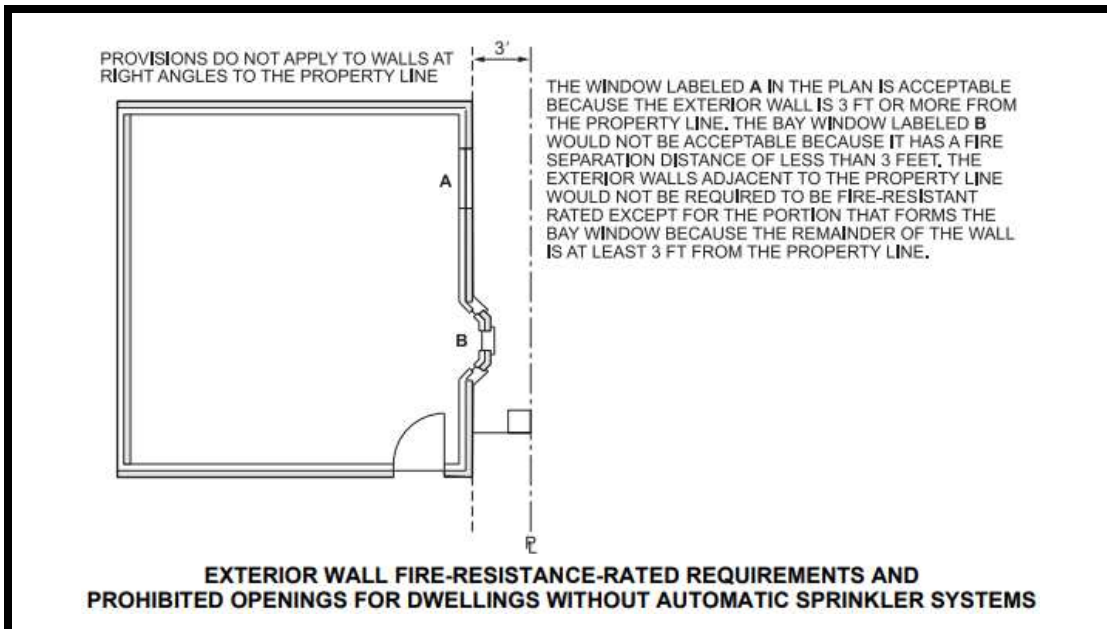
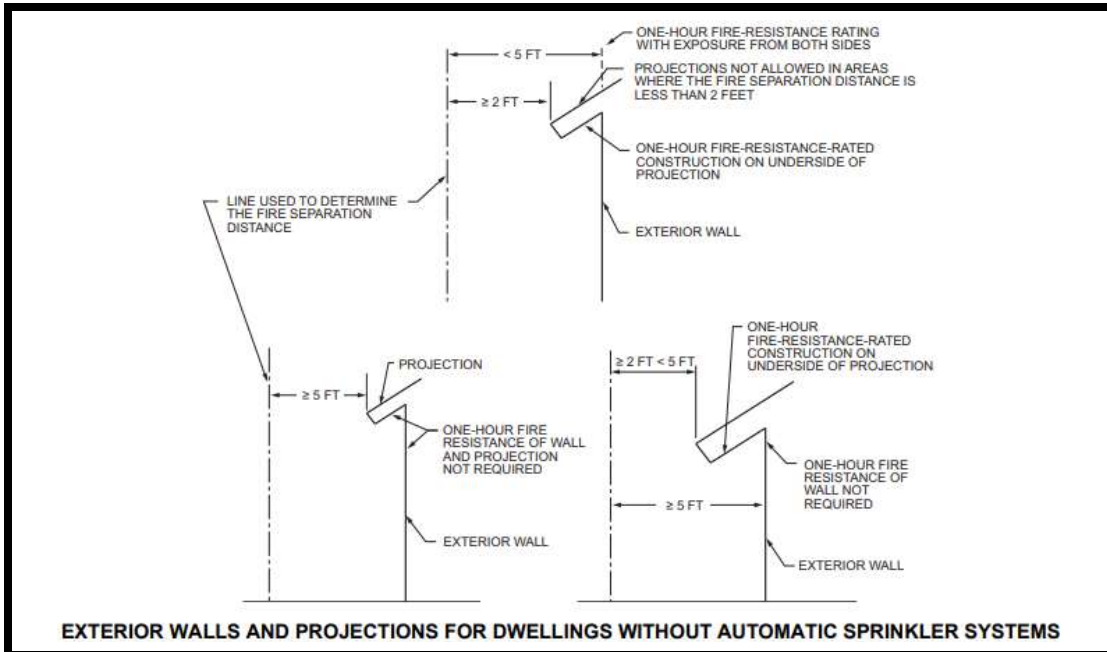

This handout was developed by the Colorado Chapter of The International Code Council as a basic plan submittal under the International Residential Code, edition 2021. It is not intended to cover all circumstances. Check with your Building Safety department for additional requirements.